



# 10 Channel LED Backlight Driver with Integrated Power Supply

The 34844 is a high efficiency, LED driver for use in backlighting LCD displays from 10" to 20"+. Operating from supplies of 7.0 to 28 V, the MC34844 is capable of driving up to 160 LEDs in 10 parallel strings. Current in the 10 strings is matched to within  $\pm 2\%$ , and can be programmed via the I<sup>2</sup>C/SM Bus interface.

The 34844 also includes a Pulse Width Monitor (PWM) generator for LED dimming. The LEDs can be dimmed to one of 256 levels, programmed through the I<sup>2</sup>C/SM Bus interface. Up to 65,000:1 (256:1 PWM, 256:1 Current DAC) dimming ratio.

The integrated boost converter generates the minimum output voltage required to keep all LEDs illuminated with the selected current, providing the highest efficiency possible. The integrated boost self-clocks at a default frequency of 600 kHz, but may be programmed via I<sup>2</sup>C to 150/300/600/1200 kHz. The PWM frequency can be set from 100 Hz to 25 kHz, or can be synchronized to an external input. If not synchronized to another source, the internal PWM rate outputs on the CK pin. This enables multiple devices to be synchronized together.

The 34844 also supports optical/temperature closed loop operation and also features LED over-temperature protection, LED short protection, and LED open circuit protection. The IC also includes over-voltage protection, over-current protection, and under-voltage lockout.

## Features

- Input voltage of 7.0 to 28 V
- Boost output voltage up to 60 V, with Dynamic Headroom Control (DHC)
- 3.0 A integrated boost FET
- Up to 50 mA LED current per channel
- 90% efficiency (DC:DC)
- 10 channel current mirror with  $\pm 2\%$  current matching
- I<sup>2</sup>C/SM Bus interface
- PWM frequency programmable or synchronizable from 100 to 25,000Hz
- 32-Ld 5x5x1.0 mm TQFN Package
- Pb-free packaging designated by suffix code EP

**34844**

**LED DRIVER**



ORDERING INFORMATION		
Device	Temperature Range (T <sub>A</sub> )	Package
MC34844EP/R2	-40°C to 105°C	32 QFN-EP

## Applications

- Monitors - up to 27 inch
- Personal Computer Notebooks
- GPS Screens
- Small screen Televisions

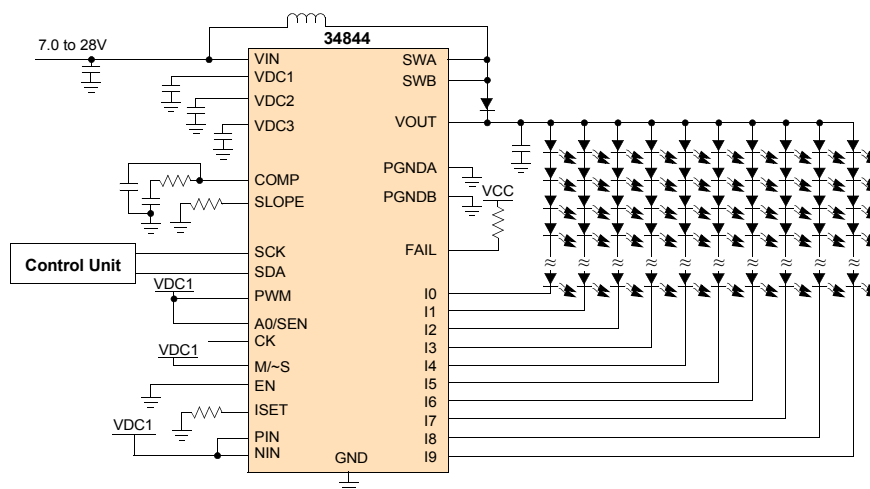

Figure 1. Simplified Application Diagram (SM Bus Mode)

\* This document contains certain information on a new product. Specifications and information herein are subject to change without notice.

### INTERNAL BLOCK DIAGRAM

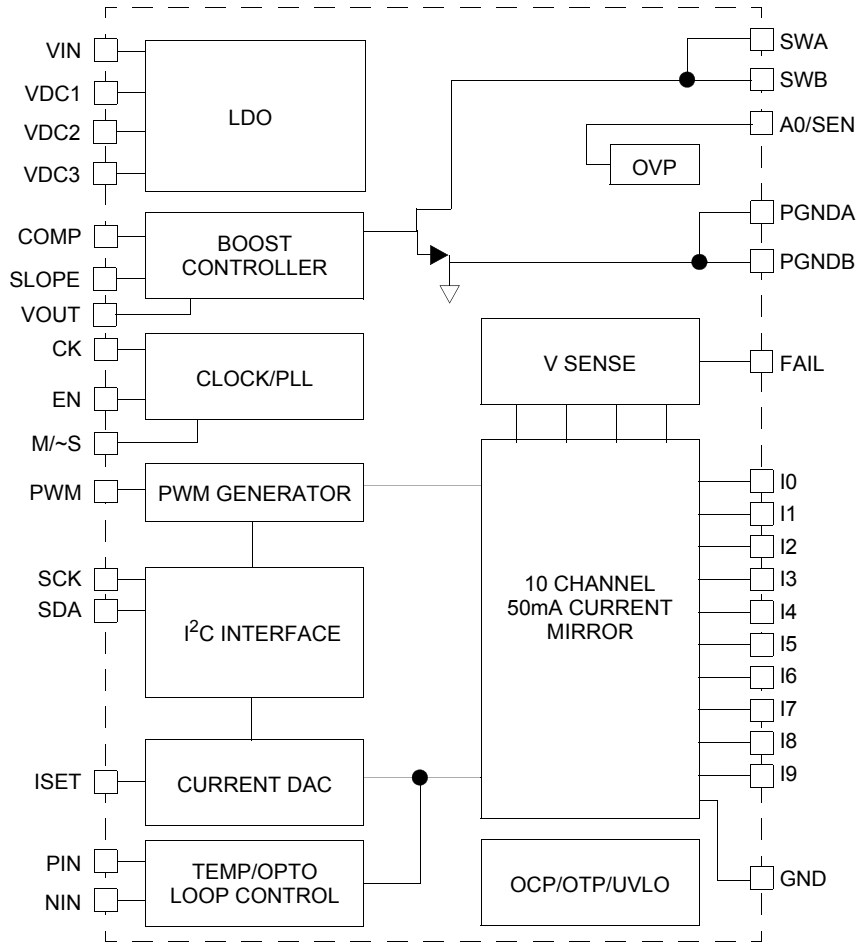
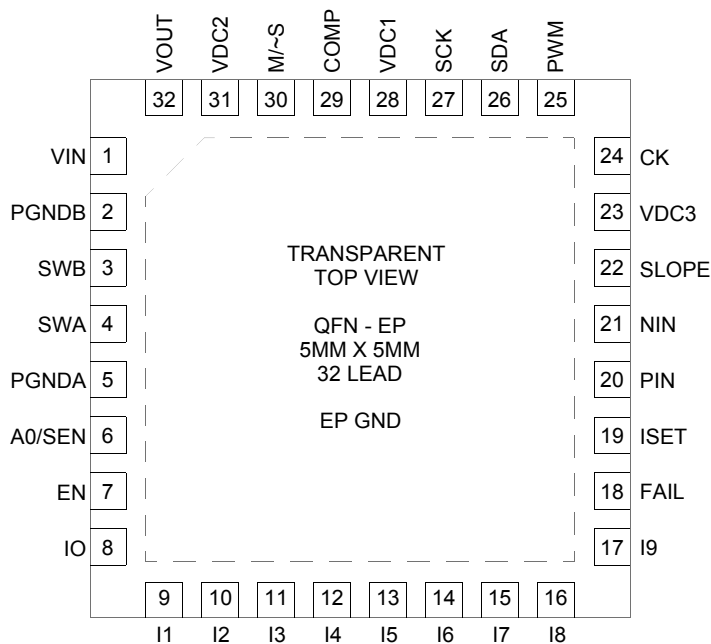

Figure 2. 34844 Simplified Internal Block Diagram

## PIN CONNECTIONS



EP = Exposed Pad

Figure 3. 34844 Pin Connections

Table 1. 34844 Pin Definitions

A functional description of each pin can be found in the Functional Pin Description section beginning on [page 11](#).

Pin Number	Pin Name	Pin Function	Formal Name	Definition
1	VIN	Power	Input voltage	Input supply
2	PGNDB	Power	Power Ground	Power ground
3	SWB	Input	Switch node B	Boost switch connection B
4	SWA	Input	Switch node A	Boost switch connection A
5	PGNDA	Power	Power Ground	Power ground
6	A0/SEN	Input	Device Select	Address select, device select pin or OVP HW control
7	EN	Input	Enable	Enable pin (active high, internal pull-up)
8 - 17	I0-I9	Input	LED Channel	LED string connections
18	FAIL	Open Drain	Fault detection	Fault detected pin (open drain): No Failure = Low-impedance Failure = High-impedance
19	ISET	Passive	Current set	LED current setting resistor
20	PIN	Input	Positive current scale	Positive input analog current control
21	NIN	Input	Negative current scale	Negative input analog current control
22	SLOPE	Passive	Boost Slope	Boost slope compensation Setting resistor
23	VDC3	Output	Internal Regulator 3	Decoupling capacitor for internal phase locked loop power
24	CK	Input/Output	Clock signal	Clock synchronization pin (input for M/~S = low - internal pull-up, output for M/~S = high)
25	PWM	Input	External PWM	External PWM input (internal pull-down)

**Table 1. 34844 Pin Definitions (continued)**

A functional description of each pin can be found in the Functional Pin Description section beginning on [page 11](#).

Pin Number	Pin Name	Pin Function	Formal Name	Definition
26	SDA	Bidirectional	I <sup>2</sup> C data	I <sup>2</sup> C data Line
27	SCK	Bidirectional	I <sup>2</sup> C clock	I <sup>2</sup> C clock line
28	VDC1	Output	Internal Regulator 1	Decoupling capacitor for internal logic rail
29	COMP	Passive	Compensation pin	Boost converter Type compensation pin
30	M/~S	Input	Master/Slave selector	Selects Master mode (1) or Slave mode (0)
31	VDC2	Output	Internal Regulator 2	Decoupling capacitor for internal regulator
32	VOUT	Input	Voltage Output	Boost Output voltage sense pin
EP	GND	-	Ground	Ground Reference for all internal circuits other than Boost FET

## MAXIMUM RATINGS

**Table 2. Maximum Ratings**

All voltages are with respect to ground unless otherwise noted. Exceeding these ratings may cause a malfunction or permanent damage to the device.

Ratings	Symbol	Value	Unit
<b>ELECTRICAL RATINGS</b>			
Maximum Pin Voltages	$V_{MAX}$		V
A0/SEN		7.0	
I0, I1, I2, I3, I4, I5, I6, I7, I8, I9,EN <sup>(4)</sup>		45	
VIN		30	
SWA, SWB, VOUT		65	
FAIL, PIN, NIN, ISET, M/~S, CK, PWM		6.0	
Maximum LED Current	$I_{MAX}$	55	mA
ESD Voltage <sup>(1)</sup>	$V_{ESD}$		V
Human Body Model (HBM)		±2000	
Machine Model (MM)		±200	
<b>THERMAL RATINGS</b>			
Ambient Temperature Range	$T_A$	-40 to 105	°C
Junction to Ambient Temperature <sup>(2)</sup>	$T_{\theta JA}$	32	°C/W
Junction to Case Temperature <sup>(2)</sup>	$T_{\theta JC}$	3.5	°C/W
Maximum junction temperature	$T_J$	150	°C
Storage temperature range	$T_{STO}$	-40 to 150	°C
Peak Package Reflow Temperature During Reflow <sup>(3)</sup>	$T_{PPRT}$	260	°C
Power Dissipation			W
TA = 25°C		3.9	
TA = 70°C		2.5	
TA = 85°C		2.0	
TA = 105°C		1.4	

**Notes**

- ESD testing is performed in accordance with the Human Body Model (HBM) (AEC-Q100-2), and the Machine Model (MM) (AEC-Q100-003),  $R_{ZAP} = 0 \Omega$
- Per JEDEC51 Standard for Multilayer PCB
- Pin soldering temperature limit is for 10 seconds maximum duration. Not designed for immersion soldering. Exceeding these limits may cause malfunction or permanent damage to the device.
- 45 V is the Maximum allowable voltage on all LED channels in off-state.

## ELECTRICAL CHARACTERISTICS

**Table 3. Electrical Characteristics**

Characteristics noted under conditions  $V_{IN} = 12\text{ V}$ ,  $V_{OUT} = 42\text{ V}$ ,  $I_{LED} = 50\text{ mA}$ ,  $PWM = VDC1$ ,  $M/\sim S = VDC1$ ,  $PIN \text{ \& } NIN = VDC1$ ,  $-40^{\circ}\text{C} \leq T_A \leq 105^{\circ}\text{C}$ ,  $PGND = 0\text{ V}$ , unless otherwise noted.

Characteristic	Symbol	Min	Typ	Max	Unit
----------------	--------	-----	-----	-----	------

**SUPPLY**

Supply Voltage	$V_{IN}$	7.0	12	28	V
Supply Current when Shutdown Mode Manual & SM Bus: EN = Low, SCK & SDA=Low $I^2C$ : EN = Low, SET $I^2C$ bit = 1, CLRI $I^2C$ bit = 0	$I_{SHUTDOWN}$	- -	2.0 17	- -	$\mu\text{A}$
Supply Current when Sleep Mode SM-Bus: EN = low, SCK & SDA= Active, SET $I^2C$ bit = 0, EN bit = 0 $I^2C$ : EN = High, SET $I^2C$ bit = 1, CLRI $I^2C$ bit = 0, EN bit = 0	$I_{SLEEP}$	-	3.0	-	mA
Supply Current when Operational Mode Manual: EN= High, SCK & SDA=Low, PWM=Low SM-Bus: EN= Low, SCK & SDA=Active, EN bit= 1, PWM=Low $I^2C$ : EN = High, SET $I^2C$ bit = 1, CLRI $I^2C$ bit = 0, EN bit = 1, PWM=Low	$I_{OPERATIONAL}$	-	10.0	-	mA
Under-voltage Lockout $V_{IN}$ Rising	UVLO	5.4	6.0	6.4	V
Under-voltage Hysteresis $V_{IN}$ Falling	UVLO <sub>HYST</sub>	150	200	250	mV
VDC1 Voltage <sup>(5)</sup> $C_{VDC1} = 2.2\ \mu\text{F}$	$V_{DC1}$	2.4	2.5	2.6	V
VDC2 Voltage <sup>(5)</sup> $C_{VDC2} = 2.2\ \mu\text{F}$	$V_{DC2}$	5.5	6.0	6.5	V
VDC3 Voltage <sup>(5)</sup> $C_{VDC3} = 2.2\ \mu\text{F}$	$V_{DC3}$	2.4	2.5	2.6	V

**BOOST**

Output Voltage Range <sup>(6)</sup> $V_{IN} = 7.0\text{ V}$ $V_{IN} = 28\text{ V}$	$V_{OUT1}$ $V_{OUT2}$	8.0 31	- -	43 60	V
Boost Switch Current Limit	$I_{FET}$	2.6	2.8	3.0	A
R <sub>DS(on)</sub> of Internal FET $I_{DRAIN} = 1.0\text{ A}$	$R_{DS(on)}$	-	250	500	m $\Omega$
Boost Switch Off-state Leakage Current $V_{SWA, SWB} = 65\text{ V}$	$I_{BOOST\_LEAK}$	-	-	10	$\mu\text{A}$
Peak Boost Efficiency <sup>(7)</sup>	$EFF_{BOOST}$	-	90	-	%

## Notes

- This output is for internal use only and not to be used for other purposes
- Minimum and Maximum output voltages are dependent on Min/Max duty cycle condition.
- Guaranteed by design

**Table 3. Electrical Characteristics (continued)**

Characteristics noted under conditions  $V_{IN} = 12\text{ V}$ ,  $V_{OUT} = 42\text{ V}$ ,  $I_{LED} = 50\text{ mA}$ ,  $PWM = VDC1$ ,  $M/\sim S = VDC1$ ,  $PIN \& NIN = VDC1$ ,  $-40^{\circ}\text{C} \leq T_A \leq 105^{\circ}\text{C}$ ,  $PGND = 0\text{ V}$ , unless otherwise noted.

Characteristic	Symbol	Min	Typ	Max	Unit
Line Regulation <sup>(8)</sup> $V_{IN} = 7.0\text{ to }28\text{ V}$	$I_{OUT}/V_{IN}$	-0.2	-	0.2	%/V
Load Regulation <sup>(8)</sup> $V_{LED} = 8.0\text{ to }65\text{ V}$ (all Channels)	$I_{OUT}/V_{LED}$	-0.2	-	0.2	%/V
Slope compensation voltage ramp $R_{SLOPE} = 68\text{ k}\Omega$	$V_{SLOPE}$	-	0.49	-	V/ $\mu\text{s}$
Current Sense Amplifier Gain	$A_{CSA}$	-	9.0	-	
Current Sense Resistor	$R_{SENSE}$	-	22	-	m $\Omega$
OTA Transconductance	$G_M$	-	200	-	$\mu\text{S}$
Transconductance Sink and Source Current Capability	$I_{SS}$	-	100	-	$\mu\text{A}$
Output Voltage Precharge	$V_{HOLD}$	0.45	0.5	0.55	V

**FAIL PIN**

Off-state Leakage Current $V_{FAIL} = 5.5\text{ V}$	$I_{FAIL\_LEAK}$	-	-	5	$\mu\text{A}$
On-state Voltage Drop $I_{SINK} = 4.0\text{ mA}$	$V_{OL}$	-	-	0.4	V

**LED CHANNELS**

Sink Current ICHx Register = 255, RISET=5.1 k $\Omega$ 0.1%, PIN&NIN = Disabled, $T_A = 25^{\circ}\text{C}$	$I_{SINK}$	49	50	51	mA
Regulated minimum voltage across drivers Pulse Width > 4.0 $\mu\text{s}$	$V_{MIN}$	675	750	825	mV
Current Matching Accuracy	$I_{MATCH}$	-2.0	-	2.0	%
$I_{SET}$ Pin Voltage RISET=5.1 k $\Omega$ 0.1%	$V_{SET}$	2.017	2.048	2.079	V
LED Current Amplitude Resolution $1.0\text{ mA} \leq I_{LED} \leq 50\text{ mA}$	$I_{LED\_RES}$	-	1.5	-	%
Off-state Leakage Current, All channels ( $V_{CH} = 45\text{ V}$ )	$I_{CH\_LEAK}$	-	-	10	$\mu\text{A}$

**PIN INPUT**

Voltage to Disable PIN mode	$V_{PIN\_DIS}$	2.2	-	-	V
PIN Bias Current $PIN = V_{SET}$	$I_{PIN}$	-2.0	-	2.0	$\mu\text{A}$
Analog Dimming Current ICHx Register = 255, RISET=5.1 k $\Omega$ 0.1% $PIN = V_{SET}/2$ $PIN = V_{SET}$	$I_{DIM\_PIN}$	23.75 47.50	25 50	26.25 52.50	mA

## Notes

8. Guaranteed by design

**Table 3. Electrical Characteristics (continued)**

Characteristics noted under conditions  $V_{IN} = 12\text{ V}$ ,  $V_{OUT} = 42\text{ V}$ ,  $I_{LED} = 50\text{ mA}$ ,  $PWM = VDC1$ ,  $M/\sim S = VDC1$ ,  $PIN \& NIN = VDC1$ ,  $-40^{\circ}\text{C} \leq T_A \leq 105^{\circ}\text{C}$ ,  $PGND = 0\text{ V}$ , unless otherwise noted.

Characteristic	Symbol	Min	Typ	Max	Unit
<b>NIN INPUT</b>					
Voltage to Disable NIN mode	$V_{NIN\_DIS}$	2.2	-	-	V
NIN Bias Current $NIN = V_{SET}$	$I_{NIN}$	-2.0	-	2.0	$\mu\text{A}$
Analog Dimming Current ICHx Register = 255, RISE=5.1 k $\Omega$ 0.1% $NIN = V_{SET}/2$ $NIN = 0\text{ V}$	$I_{DIM\_NIN}$	23.75 47.50	25 50	26.25 52.50	mA

**OVER-TEMPERATURE PROTECTION**

Over-temperature Threshold <sup>(9)</sup> Rising Hysteresis	$O_{TT}$	150 -	165 25	175 -	$^{\circ}\text{C}$
---	----------	----------	-----------	----------	--------------------

**I<sup>2</sup>C/SM BUS PHYSICAL LAYER [SCK, SDA]**

I <sup>2</sup> C Address	$ADR_{I2C}$	-	1110110	-	Binary
SM-Bus Address	$ADR_{SMB}$	-	1110110	-	Binary
Input Low Voltage	$V_{ILI}$	-0.3	-	0.8	V
Input High Voltage	$V_{IHI}$	2.1	-	5.5	V
Input Hysteresis	$V_{HYSI}$	0.3	-	-	V
Output Low Voltage Sink Current $\leq 4.0\text{ mA}$	$V_{OLI}$	-	-	0.4	V
Input Current	$I_{INI}$	-5.0	-	5.0	$\mu\text{A}$
Input Capacitance <sup>(9)</sup>	$C_{INI}$	-	-	10	$\mu\text{F}$

**LOGIC INPUTS / OUTPUTS (CK, M/~S, PWM, A0/SEN)**

Input Low Voltage	$V_{ILL}$	-0.3	-	0.5	V
Input High Voltage	$V_{IHL}$	1.5	-	5.5	V
Input Hysteresis	$V_{HYSL}$	-	0.1	-	V
Input Current	$I_{IIL}$	-5.0	-	5.0	$\mu\text{A}$
Output Low Voltage (CK) $I_{SINK} \leq 2.0\text{ mA}$	$V_{OLL}$	-	-	0.2	V
Output High Voltage (CK) $I_{SOURCE} \leq 2.0\text{ mA}$	$V_{OHL}$	2.2	-	5.5	V
Input Capacitance <sup>(9)</sup>	$C_{INI}$	-	-	5.0	$\mu\text{F}$

## Notes

9. Guaranteed by design



**Table 3. Electrical Characteristics (continued)**

Characteristics noted under conditions  $V_{IN} = 12\text{ V}$ ,  $V_{OUT} = 42\text{ V}$ ,  $I_{LED} = 50\text{ mA}$ ,  $PWM = VDC1$ ,  $M/\sim S = VDC1$ ,  $PIN \& NIN = VDC1$ ,  $-40^{\circ}\text{C} \leq T_A \leq 105^{\circ}\text{C}$ ,  $PGND = 0\text{ V}$ , unless otherwise noted.

Characteristic	Symbol	Min	Typ	Max	Unit
<b>OVER-VOLTAGE PROTECTION</b>					
Over-voltage Clamp - OVP Register Table:					
OVP = Fh	$OVP_{FH}$	60.5	62.5	64.5	V
OVP = Eh	$OVP_{EH}$	56.5	58	60	V
OVP = Dh	$OVP_{DH}$	53	54	56	V
OVP = Ch	$OVP_{CH}$	49	51	52.5	V
OVP = Bh	$OVP_{BH}$	45	47	48.5	V
OVP = Ah	$OVP_{AH}$	41	43	44.5	V
OVP = 9h	$OVP_{9H}$	38	39	40.5	V
OVP = 8h	$OVP_{8H}$	34	36	37.5	V
OVP = 7h	$OVP_{7H}$	30.5	32	33.5	V
OVP = 6h	$OVP_{6H}$	26	28	30	V
OVP = 5h	$OVP_{5H}$	23	24	25	V
OVP = 4h	$OVP_{4H}$	19	20	21	V
OVP = 3h	$OVP_{3H}$	15	16	17	V
OVP = 2h	$OVP_{2H}$	11	12	13	V
Over-voltage threshold, Set by Hardware, Voltage at A0/SEN	$OVP_{HW}$	6.15	6.5	6.85	V
A0/SEN Sink Current	$I_{SINK\_OVP}$	-	100	-	$\mu\text{A}$
<b>BOOST</b>					
Switching Frequency (BST [1:0]=0)	$f_{SW0}$	0.14	0.15	0.17	MHz
Switching Frequency (BST [1:0]=1)	$f_{SW1}$	0.27	0.30	0.33	MHz
Switching Frequency (BST [1:0]=2)	$f_{SW2}$	0.54	0.60	0.66	MHz
Switching Frequency (BST [1:0]=3)	$f_{SW3}$	1.08	1.2	1.32	MHz
Minimum Duty Cycle	$D_{MIN}$	-	10	15	%
Maximum Duty Cycle	$D_{MAX}$	80	85	-	%
Soft Start Period	$t_{SS}$	-	6.5	-	ms
Boost Switch Rise Time <sup>(9)</sup>	$t_{TR}$	-	15	-	ns
Boost Switch Fall Time <sup>(9)</sup>	$t_F$	-	25	-	ns

## Notes

10. Guaranteed by design

**Table 3. Electrical Characteristics (continued)**

Characteristics noted under conditions  $V_{IN} = 12\text{ V}$ ,  $V_{OUT} = 42\text{ V}$ ,  $I_{LED} = 50\text{ mA}$ ,  $PWM = VDC1$ ,  $M/\sim S = VDC1$ ,  $PIN \& NIN = VDC1$ ,  $-40^\circ\text{C} \leq T_A \leq 105^\circ\text{C}$ ,  $PGND = 0\text{ V}$ , unless otherwise noted.

Characteristic	Symbol	Min	Typ	Max	Unit
----------------	--------	-----	-----	-----	------

**PWM GENERATOR**

PWM Frequency Range <sup>(12)</sup> M/~S = Low (Slave Mode)	fPWS <sub>S</sub>	100	-	25000	Hz
PWM Frequency M/~S = High (Master Mode) FPWM Register = 768 FPWM Register = 192,000	fPWS <sub>M</sub>	22500 90	25000 100	27500 110	Hz
PWM dimming resolution	t <sub>PWM</sub>	-	0.39	-	%

**PWM PIN (DIRECT PWM CONTROL)**

Input PWM Pin Minimum Pulse <sup>(12)</sup>	t <sub>PWM_IN</sub>	150	-	-	ns
Input PWM Frequency Range	fPWM	100	-	23000	Hz

**PHASE LOCK LOOP**

CK Slave Mode Frequency Lock Range <sup>(11)</sup> M/~S = Low (Slave Mode)	fCK <sub>S</sub>	100	-	25000	Hz
CK Slave Mode Input Jitter <sup>(12)</sup> M/~S = Low (Slave Mode)	fCK <sub>S_JITTER</sub>	-	-	0.1	%
Slave Mode Acquisition Time M/~S = Low (Slave Mode) FPWS <sub>S</sub> =25 kHz FPWS <sub>S</sub> =100 Hz	T <sub>S_ACQ</sub>	- -	- 2000	50 -	ms ms
CK Frequency (Master Mode) FPWM Register = 768 FPWM Register = 192,000	fCK <sub>MASTER</sub>	22500 90	25000 100	27500 110	Hz

**I<sup>2</sup>C/SM BUS PHYSICAL LAYER [SCK, SDA]**

Interface Frequency Range	f <sub>SCK</sub>			400	kHz
SM Bus Power-on-Reset Time	t <sub>RST</sub>	-	-	100	ms
Output fall time 10 pF ≤ C <sub>L</sub> ≤ 400 pF	t <sub>F</sub>	40	-	160	ns
Output rise time 10 pF ≤ C <sub>L</sub> ≤ 400 pF	t <sub>R</sub>	20	-	80	ns

**LOGIC OUTPUT (CK)**

Output Rise and Fall time <sup>(11)</sup> C <sub>L</sub> ≤ 100 pF	t <sub>R</sub> /t <sub>F</sub>	-	-	25	ns
--	--------------------------------	---	---	----	----

**LED CHANNELS**

Channels Rise and Fall Time <sup>(12)</sup>	t <sub>R</sub> /t <sub>F</sub>	-	23	50	ns
---	--------------------------------	---	----	----	----

## Notes

- Special considerations should be made for frequencies between 100 Hz to 1.0 KHz. Please refer to [Functional Device Operation](#) for further details.
- Guaranteed by design

## FUNCTIONAL DESCRIPTION

### INTRODUCTION

LED backlighting has become very popular for small and medium LCDs, due to some advantages over other backlighting schemes, such as the widely used cold cathode fluorescent lamp (CCFL). The advantages of LED backlighting are low cost, long life, immunity to vibration, low operational voltage, and precise control over its intensity.

However, there is an important drawback of this method. It requires more power than most of the other methods, and this is a major problem if the LCD size is large enough.

To address the power consumption problem, solid state optoelectronics technologies are evolving to create brighter LEDs with lower power consumption. These new technologies together with highly efficient power management LED drivers are turning LEDs, a more suitable solution for backlighting almost any size of LCD panel, with really conservative power consumption.

One of the most common schemes for backlighting with LED is the one known as "Array backlighting". This creates a matrix of LEDs all over the LCD surface, using defraction and diffused layers to produce an homogenous and even light at

the LCD surface. Each row or column is formed by a number of LEDs in series, forcing a single current to flow through all LEDs in each string.

Using a current control driver, per row or column, helps the system to maintain a constant current flowing through each line, keeping a steady amount of light even with the presence of line or load variations. They can also be use as a light intensity control by increasing or decreasing the amount of current flowing through each LED string.

To achieve enough voltage to drive a number of LEDs in series, a boost converter is implemented, to produce a higher voltage from a smaller one, which is typically used by the logical blocks to do their function.

The 34844 implements a single channel boost converter together with 10 input channels, for driving up to 16 LEDs per string to create a matrix of more than 160 LEDs. Together with its 90% efficiency and I<sup>2</sup>C programmable or external current control, among other features, makes the 34844 a perfect solution for backlighting small and medium size LCD panels, on low power portable and high definition devices.

### FUNCTIONAL PIN DESCRIPTION

#### INPUT VOLTAGE SUPPLY (VIN)

IC Power input supply voltage, is used internally to produce internal voltage regulation (VDC1, VDC3) for logic functioning, and also as an input voltage for the boost regulator.

#### INTERNAL VOLTAGE REGULATOR 1 (VDC1)

This pin is for internal use only, and not to be used for other purposes. A capacitor of 2.2  $\mu$ F should be connected between this pin and ground for decoupling purposes.

#### INTERNAL VOLTAGE REGULATOR 2 (VDC2)

This pin is for internal use only, and not to be used for other purposes. A capacitor of 2.2  $\mu$ F should be connected between this pin and ground for decoupling purposes.

#### INTERNAL VOLTAGE REGULATOR 3 (VDC3)

This pin is for internal use only, and not to be used for other purposes. A capacitor of 2.2  $\mu$ F should be connected between this pin and ground for decoupling purposes.

#### BOOST COMPENSATION PIN (COMP)

Passive terminal used to compensate the boost converter. Add a capacitor and a resistor in series to GND to stabilize the system.

#### IC ENABLE (EN)

The active high enable terminal is internally pulled high through pull-up resistors. Applying 0V to this terminal would stop the IC from working.

#### INPUT/OUTPUT CLOCK SIGNAL (CK)

This terminal can be used as an output clock signal (master mode), or input clock signal (slave mode), to synchronize more than one device.

#### MASTER/SLAVE MODE SELECTION (M/~S)

Setting this pin High puts the device into Master mode, producing an output synchronization clock at the CK terminal. Setting this pin low, puts the device in Slave mode, using the CK pin as an input clock.

#### EXTERNAL PWM INPUT (PWM)

This terminal is internally pulled down. An external PWM signal can be applied to modulate the LED channel directly in absence of an I<sup>2</sup>C interface.

#### CLOCK I<sup>2</sup>C SIGNAL (SCK)

Clock line for I<sup>2</sup>C communication.

#### ADDRESS I<sup>2</sup>C SIGNAL (SDA)

Address line for I<sup>2</sup>C communication.

## **A0/SEN**

Address select, device select pin, or Hardware Over-voltage Protection (OVP) Control.

## **CURRENT SET (ISET)**

Each LED string can drive up to 50 mA. The maximum current can be set by using a resistor from this pin to GND.

## **POSITIVE CURRENT SCALING (PIN)**

Positive current scaling factor for the external analog current control. Applying 0 V to this pin, scales the current to 0%, and in the same way, applying 2.048 V (Vset), the scale factor is 100%. By applying a voltage higher than 2.2 V, the scaling factor is disabled, and the internal pull-ups are activated.

If PIN pin and NIN pin are used at the same time then by applying 0 V to the PIN pin and 2.048 V to NIN pin, scales the current to 0%, and in the same way, applying 2.048 V to the PIN pin and 0 V to NIN pin, scales the current to 100%. By applying a voltage higher than 2.2 V, the scaling factor is disabled and the internal pull-ups are activated in both pins.

## **NEGATIVE CURRENT SCALING (NIN)**

Negative current scaling factor for the external analog current control. Setting 0 V to this pin scales the current to 100%, in the same way, setting 2.048 V (Vset) the scale factor is 0%. By applying a voltage higher than 2.2 V, the scaling factor is disabled and the internal pull-ups are activated.

If PIN pin and NIN pin are used at the same time then by applying 0 V to the PIN pin and 2.048 V to NIN pin, scales the current to 0%, and in the same way, applying 2.048 V to the PIN pin and 0 V to NIN pin, scales the current to 100%. By

applying a voltage higher than 2.2 V, the scaling factor is disabled and the internal pull-ups are activated in both pins.

## **GROUND (GND)**

Ground Reference for all internal circuits other than the Boost FET.

The Exposed Pad (EP) should be used for thermal heat dissipation.

## **I0-I9**

Current LED driver, each line has the capability of driving up to 50 mA.

## **FAULT DETECTION PIN (FAIL)**

When a fault situation is detected, this pin goes into high impedance.

## **BOOST SLOPE COMPENSATION SETTING RESISTOR (SLOPE)**

Use an external resistor of about 68 k $\Omega$  to configure the Boost compensation slope.

## **POWER GROUND TERMINALS (PGNDA, PGNDB)**

Ground terminal for the internal Boost FET.

## **OUTPUT VOLTAGE SENSE TERMINAL (VOUT)**

Input terminal to monitor the output voltage. It also supplies the input voltage for the internal regulator 2 (VDC2).

## **SWITCHING NODE TERMINALS (SWA, SWB)**

Switching node of boost converter.

**FUNCTIONAL INTERNAL BLOCK DESCRIPTION**

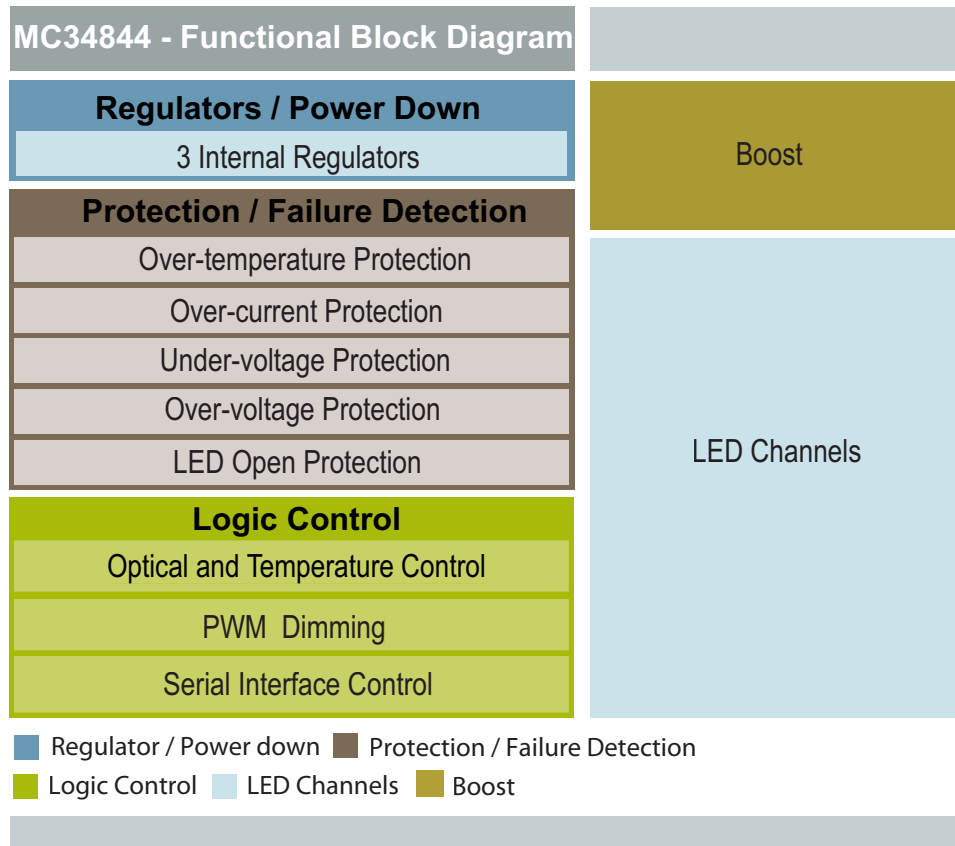

**Figure 4. Functional Internal Block Diagram**

**REGULATORS/ POWER DOWN**

The 34844 is designed to operate from input voltages in the 7.0 to 28 V range. This is stepped down internally by LDOs to 2.5 V (VDC1 and VDC3) and 6 V (VDC3) for powering internal circuitry. If the input voltage falls below the UVLO threshold, the device automatically enters in power down mode.

**Operating Modes:**

The device can be operated by the EN pin and/or SDA/ SCK bus lines, resulting in three distinct operation modes:

- Manual mode, there is no I<sup>2</sup>C capability, the bus line pins must be tied low, and the EN pin controls the ON/OFF operation.

- SM Bus mode, EN pin must be tied low and the device is turned ON by any activity on the bus lines. The part shuts down if the bus lines are held low for more than 27 ms, the 27 ms watchdog timer can be disabled by I<sup>2</sup>C (setting SETI2C bit high) or tying the EN pin high. In Sleep mode (EN bit=0) the device reduces the power consumption by leaving “alive” only the blocks required for I<sup>2</sup>C communication.
- I<sup>2</sup>C mode, has to be configured by I<sup>2</sup>C communication (SETI2C bit = 1) right after the IC is turned ON, it prevents the part from being turned ON/OFF by the bus. Sleep mode is also present and it is intended to save power, but still keep the IC prepared to communicate by I<sup>2</sup>C. Turning the EN pin OFF, the chip enters into a low power mode.

MODE	EN Pin	SCK/SDA Pins	I <sup>2</sup> C Bit Command	Current Consumption Mode	Comments
Manual	Low	Low	N/A	Shutdown	
	High	Low	N/A	Operational	
SM Bus	Low	Low (> 27 ms)	EN bit = X	Shutdown	
	Low	Active	EN bit = 0	Sleep	
	Low	Active	EN bit = 1	Operational	
I <sup>2</sup> C	Low	X	SETI2C bit = 1	I <sup>2</sup> C Low Power (Shutdown)	Part Doesn't Wake-up
			CLR I2C bit = 0		
			EN bit = X		
	High	X	SETI2C bit = 1	Sleep	
			CLR I2C bit = 0		
			EN bit = 0		
	High	X	SETI2C bit = 1	Operational	
			CLR I2C bit = 0		
			EN bit = 1		

**Table 4. Operation Current Consumption Modes**

**BOOST**

The integrated boost converter operates in non-synchronous mode and integrates a 3.0 A FET. An integrated sense circuit is used to sense the voltage at the LED current mirror inputs and automatically sets the boost output voltage (DHC) to the minimum voltage needed to keep all LEDs biased with the required current. The DHC is designed to operate under specific pulse width conditions in the LED drivers. It operates for pulse widths higher than 4.0 μs

If the pulse widths are shorter than specified, the DHC circuit will not operate and the voltage across the LED drivers will increase to a value given by the OVP minus the total LED voltage in the LED string. Therefore it is imperative to select the proper OVP level to minimize power dissipation.

The OVP can be set from 11 to 62 V, ~4.0 V spaced, using the I<sup>2</sup>C interface (OVP Register). If I<sup>2</sup>C capability is not present, the OVP can be controlled by a resistor divider connected from VOUT to GND with its mid point tied to A0/SEN pin (threshold = 6.5 V). During an OVP condition, the output voltage will go to the OVP level which is programmed via the I<sup>2</sup>C interface or settled by a resistor divider on A0/SEN pin, or by a zener diode. The formulas to calculate the hardware OVP using any of the two methods are as follows:

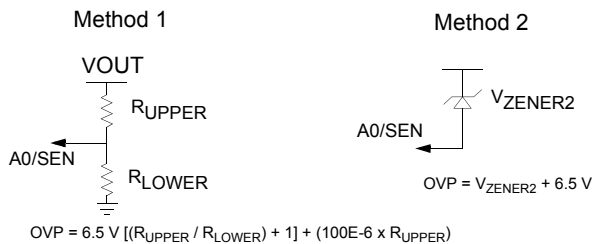

**HARDWARE OVP:**

The OVP value should be set to greater than the maximum LED voltage over the whole temperature range. A good practice is to set it 5.0 V or so above the max LED voltage.

The boost converter also features internal Over-current Protection (OCP) and has a user programmable Over-voltage Protection (OVP).

The OCP operates on a cycle by cycle basis. However, if the OCP condition remains for more than 10ms then the device turns off the LED Drivers, the Boost goes to Sleep mode and the output FAULT pin goes into high-impedance. The device can only be restarted by recycling the enable or creating a Power On Reset (POR).

The user can program the boost frequency by I<sup>2</sup>C (BST[1:0]) only after the IC is powered up and before the boost circuit is turned ON for the first time (PWM pin low to high). This sequence avoids boost frequency to be changed inadvertently during operation. The first I<sup>2</sup>C command has to wait for 5.0 ms after the part is turned ON, in order to allow sufficient time for the device power up sequence to be completed.

The boost controller has an integral track and hold amplifier with indefinite hold time capability, to enable immediate LED on cycles after extended off times. During extended off times, the external LEDs cool down from their normal quiescent operating temperature and thereby experience a forward voltage change, typically an increase in the forward voltage. This change can be significant for applications with a large number of series LEDs in a string operating at high current. If the boost controller did not track this increased change, the potential on the LED drivers would saturate for a few cycles once the LED channels are re-enabled.

Also the device has a precharge voltage that add 0.5 Volts to the Boost, cycle by cycle of the PWM. It helps the boost to respond faster every time the load turns back on again.

## CURRENT MIRROR

The programmable current mirror matches the current in 10 LED strings to within 2%. The maximum current is set using a resistor to GND from the ISET pin. This can be scaled down using the I<sup>2</sup>C interface to 255 levels.

Zero current is achieved by turning off the LED Driver by I<sup>2</sup>C (registers CHENx = 0h) for a duty cycle from 0% to 99% or by pulling PWM pin low regardless of the duty cycle.

I<sup>2</sup>C capability allows the channels to be controlled individually or in parallel.

**Current on LED Channel (PIN and NIN mode disabled) Eqn. 1**

$$\text{Current[A]} = \frac{\text{ICH[RegisterValue]}}{\text{RSET[ohms]}}$$

In the off state, the LEDs current is set to 0 and the boost converter stops switching.

This feature allows to drive more than 50 mA of current by connecting the LED string to 2 or more LED channels in parallel. For example; if the application requires to drive 5 channels at 100 mA, then the bottom of each LED string should be connected to two channels in order to duplicate the current capability (Example: CH0+CH1 = 100 mA).

## PWM GENERATOR

The PWM generator can operate in either master or slave modes, as set by the M/~S pin.

In master mode, the internal PWM generator frequency is programmed through the I<sup>2</sup>C interface (registers FPWM). The default programmed value set the number of 25 kHz clocks (40 μs) in one PWM cycle. The 18-bit resolution allows minimum PWM frequencies of 100 Hz to be programmed. The resulting frequency is output on the CK pin.

**PWM Frequency Eqn. 2**

$$\text{PWMPFrequency[Hz]} = \frac{19.2\text{Mhz}}{\text{FPWM[RegisterValue]}}$$

In slave mode, the CK pin acts as an input. The internal digital PLL uses this frequency as the PWM frequency. By setting one device as master, and connecting the CK output to the input on a number of slave configured devices, all PWM frequencies are synchronized together.

The duty cycle of the PWM waveform in both master and slave modes is set using a second register on the I<sup>2</sup>C interface (register DPWM), and can be controlled from 100% duty cycle to 1/256 T<sub>pwm</sub> = 0.39%. Zero percent of duty cycle is achieved by turning LED drivers off (register CHENx = 0h) or pulling PWM pin low.

An external PWM can also be used. The PWM input is 'AND'ed with the internal signal. By setting the serial interface to 100% duty cycle (default), the external pin has full control

of the PWM duty cycle. This pin can also be used to modulate the LED at a lower frequency than the PWM dimming frequency (Minimum pulse width = 150 ns).

A pulsed mode can also be programmed using the I<sup>2</sup>C interface (STROBE bit = 1). In this mode, each rising edge of the PWM signal turns on the next channel, while turning off all other channels. The duration that the channel is illuminated is set by the duty cycle of the PWM input pin. This can be used to scan the output channels.

## DISABLING LED CHANNELS

MC34844 allows the user to enable and disable each of the 10 channels separately by writing the corresponding CHENx bit on Registers 08 and 09 thru I<sup>2</sup>C.

When a channel is disabled thru I<sup>2</sup>C prior the device starts to operate, the corresponding LED driver is disabled but the feedback circuit is still connected. This may interfere with the operation of the dynamic headroom control (DHC) which can lead to erratic output voltage regulation. For this condition, the output voltage may ramp up to the OVP level if the voltage on the LED driver is not substantially above the DHC regulation voltage (0.75 V typ). Because of this operation under I<sup>2</sup>C/SMBUS Mode, we recommend to connect the unused channels to VDC2 thru a 100 kohm resistor and also follow the below powering up sequence:

1. PWM pin = Low.
2. Power up the part.
3. Program the I<sup>2</sup>C commands and disable the unused channels.
4. Enable the Boost and current drivers by taking PWM pin to HIGH.

This previous device's operation does not happen when all channels are being used because the voltage across the LED drivers is always equal or higher than the DHC regulation voltage (0.75 V typ). For this condition, the user can disable/enable any of the channels thru I<sup>2</sup>C without causing any erratic behavior but the FAIL pin cannot be cleared. If FAIL pin is to be cleared thru I<sup>2</sup>C, it will be necessary to use the suggested configuration shown at the FAIL PIN session.

## FAIL PIN

If a LED fails open in any of the LED strings, the voltage in that particular LED channel will be close to ground and the LED open failure is detected. When this happens, a failure is registered, the FAIL pin is set to its high-impedance stage, and the channel is turned off.

The FAIL pin cannot be cleared for manual mode unless a complete power on reset is applied. However for I<sup>2</sup>C/SMBUS mode, the FAIL pin is cleared by disabling the malfunction channels (CHENx = 0) and clearing the failure bit (CLRFAIL bit = 1).

If the application only requires clearing the failure for the floating or unused channels, then the unused channels must be connected to VDC2 thru a 100 kohm resistor to avoid

reach instability problems. This will allow detecting another failure from the connected channels. (See [Figure 5](#))

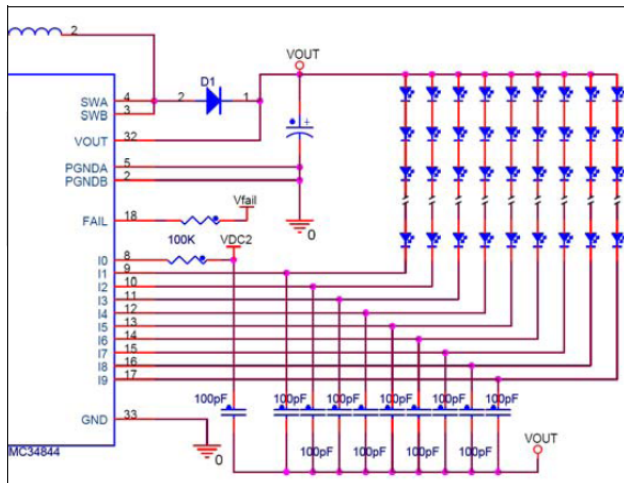

**Figure 5. Single Channel Disconnect Circuit.**

For applications where multiple failure detection is required, then one 100 kohm resistor must be placed from each channel to a diode (D2) connected to VDC2. The resistor will provide a pull up voltage to the disconnected channels so that they do not interfere with the DHC circuit. The diode (D2) ensures that when the connected channels are in PWM off state the LED strings do not conduct current to VDC2. (See [Figure 6](#))

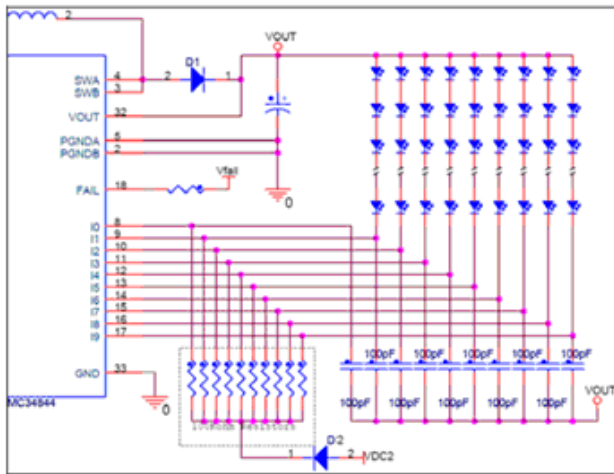

**Figure 6. Resistor/Diode placement for multiple open circuit detection**

If the fail pin cannot be cleared by software then it indicates that the failure is because of an over-current in the Boost.

Since this is a critical failure the only way to clear it is by releasing the part from the over-current condition and then shutdown the part (Refer to [Table 4](#))

If I2C communication is not present, FAIL condition should be reset by removing the failure and re-enabling the device thru the EN pin.

## OPTICAL AND TEMPERATURE CONTROL LOOP

The 34844 supports both optical and temperature loop control.

For temperature loop control, the LED brightness can be adjusted depending on the temperature of the LEDs.

For optical loop control, the 34844 supports both optical closed loop backlight control, where the brightness of the backlight is maintained at a required level by adjusting the light output, until the desired level is achieved, or with ambient light control, where the backlight brightness increases as ambient light increases.

Both temperature and optical loops are supported through the PIN and NIN pins. Each pin supports a 0-2.048 V input range which affects the current through the LEDs. The PIN pin increases current as the voltage rises from 0-2.048 V. The NIN pin reduces current as the voltage rises from 0-2.048 V.

A 10.2 k resistor or higher value must be used at the ISET pin if the part is configured to use PIN+NIN control loop functionality, the 50 mA maximum current is achieved at the higher allowed level of PIN/NIN pins, ensuring the maximum current of the LED Drivers are not exceeded.

The optical and temperature control loop can be disabled by I<sup>2</sup>C setting bits (PINEN & NINEN), or by tying PIN and NIN pins high (>2.2 V) it is called V<sub>SET</sub> mode, and the LED Driver maximum current is set to 50 mA by using a 5.1 k resistor at the ISET pin.

**Current on LED Channel (PIN mode)** Eqn. 3

$$\text{Current[A]} = \frac{(\text{VPIN} \times \text{ICH}[\text{RegisterValue}])}{\text{RSET}[\text{ohms}]}$$

**Current on LED Channel (NIN mode)** Eqn. 4

$$\text{Current[A]} = \frac{(2.048 - \text{VNIN}) \times \text{ICH}[\text{RegisterValue}]}{\text{RSET}[\text{ohms}]}$$

**Current on LED Channel (PIN+NIN mode)** Eqn. 5

$$\text{Current[A]} = \frac{(2.048 - \text{VNIN} + \text{VPIN}) \times \text{ICH}[\text{RegisterValue}]}{\text{RSET}[\text{ohms}]}$$

## LED FAILURE PROTECTION

### Open LED Protection

If LED fails open in any of the LED strings, the voltage in that channel will be pulled close to zero, which will cause the channel to be disabled. As a result, the boost output voltage



will go to the OVP level and then come down to the regulation level to continue powering the rest of the LED strings.

#### Short LED Protection

If an LED shorted in any of the LED strings, the device will continue to operate without interruption. However, if the shorted LED happens to be in the LED string with the highest forward voltage, the DHC circuit will automatically regulate the output voltage with respect to the new highest LED voltage. If more LEDs are shorted in the same LED string, it may cause excessive power dissipation in the channel which may cause the OTT circuit to trip which will completely shutdown the device.

#### OVER-TEMPERATURE PROTECTION

The 34844 has an on-chip temperature sensor that measures die temperature. If the IC temperature exceeds the

OTT threshold, the IC will turn off all power sources inside the IC (LED drivers, boost and internal regulators) until the temperature falls below the falling OTT threshold. Once it comes back on, it will operate with the default configuration (refer to [Table 6](#)).

#### SERIAL INTERFACE CONTROL

The 34844 uses an I<sup>2</sup>C interface capable of operating in standard (100 kHz) or fast (400 kHz) modes.

The A0/SEN pin can be used an address select pin to allow more than 2 devices in the system. The A0/SEN pin should be held low on all chips expect the one to be addressed, where it is taken HIGH.

## FUNCTIONAL DEVICE OPERATION

### OPERATIONAL MODES

#### NORMAL MODE

In normal operation the 34844 is programmed via I<sup>2</sup>C to drive up to 50 mA of current through each one of the LED channels. The 34844 can be configured in master or slave mode as set by the M/~S pin.

In **Master mode**, the internal PWM generator frequency is programmed through the I<sup>2</sup>C interface. The programmed value sets the number of 25 kHz clocks (40μs) in one PWM cycle. The 18-bit resolution allows minimum PWM frequencies of 100 Hz to be programmed. The resulting frequency is output on the CK pin.

In slave mode, the CK pin acts as an input. The internal digital PLL uses this frequency as the PWM frequency.

By setting one device as a master, and connecting the CK output to the input on a number of slave configured devices, all PWM frequencies are synchronized together. For this application A0/SEN pin indicates which device is enable for I<sup>2</sup>C control.

In **Slave mode**, an internal phase lock loop will lock the internal PWM generator period to the period of the signal present at the CK pin. The PLL can lock to any frequency from 100 Hz to 25 KHz provided the jitter is below 1000 ppm. At frequencies above 1.0 KHz, the PLL will maintain lock regardless of the transient power conditions imposed by the user (i.e. going from 0% duty cycle to 100% at 20W LED display power). Below 1.0 kHz, thermal time constants on the die are such that the PLL may momentarily lose lock if the die temperature changes substantially during a large load power step. As explained below, this anomaly can be avoided by controlling the rate of change in PWM duty cycle.

To better understand this issue, consider that the on chip PLL uses a VCO that is subject to thermal drift on the order of 1000 ppm/C. Further consider that the thermal time constant of the chip is on the order of single digit milliseconds. Therefore, if a large power load step is imposed by the user (i.e. going from 0% duty cycle to 100% duty cycle with a load power of 20 W), the die will experience a large temperature wave gradient that will propagate across the chip surface and thereby affect the instantaneous frequency of the VCO. As long as such changes are within the bandwidth of the PLL, the PLL will be able to track and maintain lock. Exceeding this rate of change may cause the PLL to lose lock and the backlight will momentarily be blanked until lock is reacquired.

At 100 Hz lock, the PLL has a bandwidth of approximately 10 Hz. This means that temperature changes on the order of 100 ms are tolerable without losing lock. But full load power changes on the order of 10 ms (i.e. 100 Hz PWM) are not tracked out and the PLL can momentarily lose lock. If this happens, as stated above, the LED drivers are momentarily disabled until lock is reacquired. This will be manifested as a

perceivable short flash on the backlight immediately after the load change.

To avoid this problem, one can simply limit large instantaneous changes in die temperature by invoking only small power steps when raising or lowering the display power at low PWM frequencies. For example, to maintain lock while transitioning from 0% to 100% duty cycle at 20 W load power and a PWM frequency of 100 Hz would entail stepping the power at a rate not to exceed 1% per 10 ms. If a load of less than 20 W is used, then the rate of rise can be increased. As the locked PWM frequency increases (i.e. use 600 Hz instead of 100 Hz), the step rate can be further increased to approximately 4% per 2.0 ms. The exact step rate to avoid loss of PLL lock is a function of essentially three things: (a) the composite thermal resistance of the user's PCB assembly, (b) the load power, and (c) the PWM frequency. For all cases below 1.0 KHz, simply using a rate of 1% duty cycle change per PWM period will be adequate. If this is too slow, the value can be optimized experimentally once the hardware design is complete. At PWM rates above 1.0 KHz, it is not necessary to control the rate of change in PWM duty cycle.

It is important to point out that when operating in the master mode, one does not need to concern themselves with loss of lock since the reference clock and the VCO clock are collocated on the die, and therefore experience the same thermal shift. Hence in master mode, once lock is initially acquired, it is not lost and no blanking of the display occurs.

The duty cycle of the PWM in both master and slave mode is set using a second register on the I<sup>2</sup>C interface.

An external PWM signal can also be applied in the PWM pin. This pin is AND'ed with the internal signal, giving the ability to control the duty cycle either via I<sup>2</sup>C or externally by setting any of the 2 signals to 100% duty cycle.

#### STROBE MODE

A strobe mode can be programmed via I<sup>2</sup>C.

In this mode, each rising edge of the PWM signal turns on the next channel, while turning off all other channels. The duration that the channel is illuminated is set by the duty cycle of the PWM input pin.

This mode can be also programmed by controlling the ON and OFF state of each LED channel via I<sup>2</sup>C.

#### MANUAL MODE

The 34844 can also be used in Manual mode without using the I<sup>2</sup>C interface. By setting the pin M/~S High, the LED dimming will be controlled by the external PWM signal. The over-voltage protection limit can be settled by a resistor divider on A0/SEN pin.

During manual mode, all internal Registers are in Default Configuration, refer [Table 6](#), under this configuration the PIN and NIN pins are enabled to scale the current capability per string and may be disabled by setting 2.2 V in the corresponding terminal.

Also in this mode, the device can be enabled as follows:

+ EN pin + PWM signal (Two Signals): In this configuration, the PWM signal applied to PWM pin will be in charge of controlling the LED dimming and a second signal will enable or disable the chip through the EN pin. [Figure 20](#)

+ PWM Signal tied to SDA pin (Just ONE signal): In this configuration the PWM pin should be tied to SDA pin. The

PWM signal applied to PWM pin will be in charge of controlling LED dimming and enable the device every time the PWM is active. For this configuration EN pin should be LOW.

### POWER DOWN MODE

If the input voltage falls below the UVLO threshold, the device enters automatically into power down mode. When in power down, the supply current is reduced below 2.0  $\mu$ A when there is no I<sup>2</sup>C activity, and it rises up when I<sup>2</sup>C interface is enabled.

## I<sup>2</sup>C BUS SPECIFICATION

MC34844 is a unidirectional device that can only be written by an external control unit. Since the device is a 7 bit address device (1110110), the control unit needs to follow a specific data transfer format which is shown below.

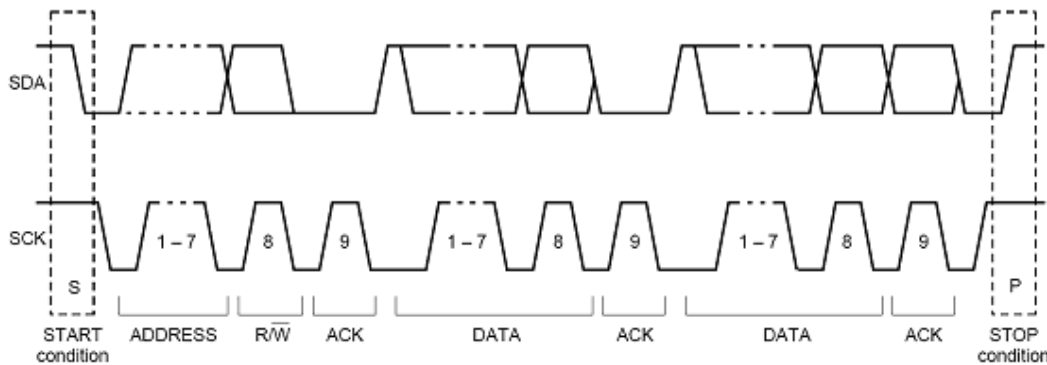

**Figure 7. A complete data transfer**

For a complete data transfer, please use this format in the following order:

1. START condition
2. MC34844 device address and Write instruction (R/W = 0)
3. First data pack, it corresponds to the MC34844 Register that needs to be written. (refer to [Table 5](#))
4. Second data pack, it corresponds to the value that should be written to that register. (refer to [Table 5](#))
5. STOP condition

I<sup>2</sup>C variables description:

- START: this condition occurs when SDA changes from HIGH to LOW while SCK is HIGH.
- ACKNOWLEDGE: The acknowledge clock pulse is generated by the Master (Control Unit).
- The transmitter releases the SDA line (HIGH) during the acknowledge clock pulse.

The receiver (MC34844) must pull down the SDA line during this acknowledge pulse to indicate that the data was correctly written.

- Bits in the first byte: The first seven bits of the first byte make up the slave address. The eighth bit is the LSB (least significant bit), which determines the direction of the message (Write = 0)

For the MC34844 device, when an address is sent, each of the devices in a system compares the first seven bits after the START condition with its address. If they match, the device considers itself addressed by the control unit as a slave-receiver.

- STOP: this condition occurs when SDA changes from LOW to HIGH while SCK is HIGH

For more information about "I<sup>2</sup>C BUS SPECIFICATION" please refer to the following link:

[http://www.nxp.com/acrobat\\_download/literature/9398/39340011.pdf](http://www.nxp.com/acrobat_download/literature/9398/39340011.pdf)

**LOGIC COMMANDS AND REGISTERS**

**Table 5. Write Registers**

REG / DB	D7	D6	D5	D4	D3	D2	D1	D0
00	OVP3	OVP2	OVP1	OVP0		NINEN	PINEN	EN
01							CLR12C	SET12C
04			FPWM5	FPWM4	FPWM3	FPWM2	FPWM1	FPWM0
05			FPWM11	FPWM10	FPWM9	FPWM8	FPWM7	FPWM6
06			FPWM17	FPWM16	FPWM15	FPWM14	FPWM13	FPWM12
07	DPWM7	DPWM6	DPWM5	DPWM4	DPWM3	DPWM2	DPWM1	DPWM0
08				CHEN4	CHEN3	CHEN2	CHEN1	CHEN0
09	STRB	CLRFAIL	ALL_OFF	CHEN9	CHEN8	CHEN7	CHEN6	CHEN5
14							BST1	BST0
F0	ICH0_7	ICH0_6	ICH0_5	ICH0_4	ICH0_3	ICH0_2	ICH0_1	ICH0_0
F1	ICH1_7	ICH1_6	ICH1_5	ICH1_4	ICH1_3	ICH1_2	ICH1_1	ICH1_0
F2	ICH2_7	ICH2_6	ICH2_5	ICH2_4	ICH2_3	ICH2_2	ICH2_1	ICH2_0
F3	ICH3_7	ICH3_6	ICH3_5	ICH3_4	ICHG_3	ICH3_2	ICH3_1	ICH3_0
F4	ICH4_7	ICH4_6	ICH4_5	ICH4_4	ICH4_3	ICH4_2	ICH4_1	ICH4_0
F5	ICH5_7	ICH5_6	ICH5_5	ICH5_4	ICH5_3	ICH5_2	ICH5_1	ICH5_0
F6	ICH6_7	ICH6_6	ICH6_5	ICH6_4	ICH6_3	ICH6_2	ICH6_1	ICH6_0
F7	ICH7_7	ICH7_6	ICH7_5	ICH7_4	ICH7_3	ICH7_2	ICH7_1	ICH7_0
F8	ICH8_7	ICH8_6	ICH8_5	ICH8_4	ICH8_3	ICH8_2	ICH8_1	ICH8_0
F9	ICH9_7	ICH9_6	ICH9_5	ICH9_4	ICH9_3	ICH9_2	ICH9_1	ICH9_0
FA	ICHG_7	ICHG_6	ICHG_5	ICHG_4	ICHG_3	ICHG_2	ICHG_1	ICHG_0

**Table 6. Register Description**

REGISTER NAME	DEFAULT VALUE (HEX)	DESCRIPTION
EN	1	Chip Enable by software. This signal is 'OR'ed with external EN (0=off, 1 =on)
PINEN	1	PIN pin enable (0=off, 1 =on)
NINEN	1	NIN pin enable (0=off, 1 =on)
OVP[3:0]	F	OVP voltage
SETI2C	0	SET I <sup>2</sup> C communication (Disable SM Bus Mode)
CLR I2C	0	Clear set I <sup>2</sup> C
FPWM[17:0]	300	PWM Frequency
DPWM[7:0]	FF	PWM Duty Cycle (FFh =100%)
CHEN[9:0]	3FF	Channel Enable (0=off, 1=on)
ALL_OFF	0	All 10 channels OFF at the same. In order to reactivate channels this bit should be clear.
CLRFail	0	Clear fail if channels are re-enable.
STRB	0	Strobe MODE (0=Parallel, 1=Strobe)
BST[1:0]	2	Boost Frequency (150,300,600,1200 kHz) [0h=150 Hz]
ICH#[7:0]	FF	Channel Current Program (FFh = Maximum Current)
ICHG[7:0]	FF	Global Current Program

**Table 7. Over Voltage Protection**

REGISTER (HEX)	OVP VALUE (VOLTS)
2	11
3	15
4	19
5	23
6	27
7	31
8	35
9	39
A	43
B	47
C	51
D	55
E	59
F	62

TYPICAL PERFORMANCE CURVES (TA=25°C)

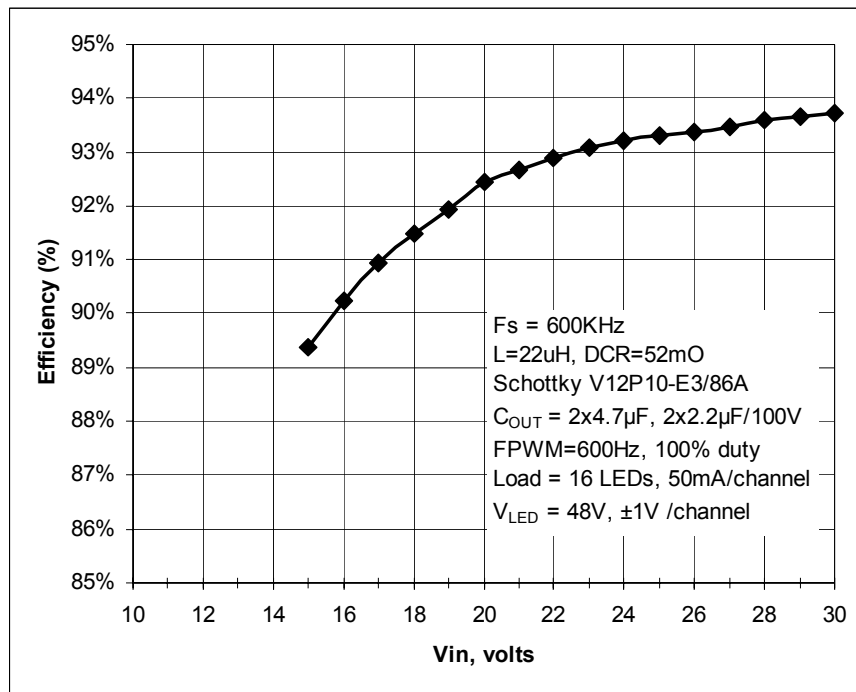

Figure 8. Boost efficiency vs Input Voltage

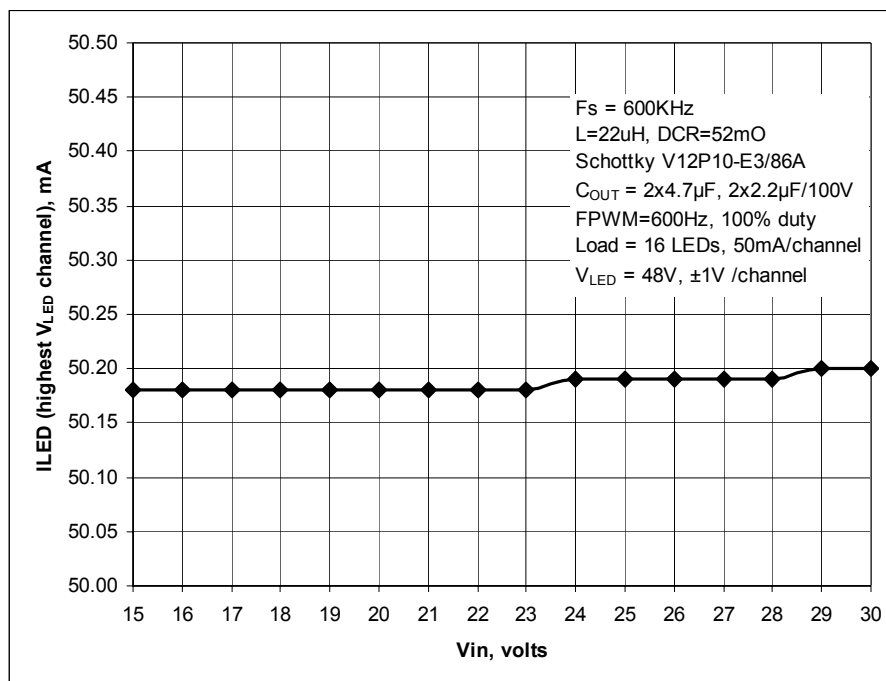

Figure 9. Line Regulation, V<sub>IN</sub> Changing

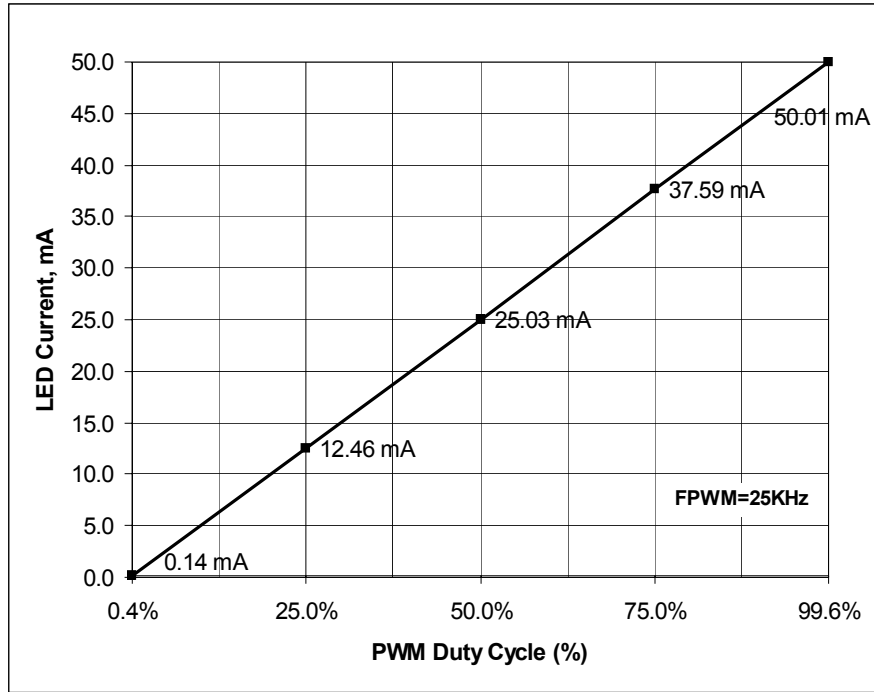

Figure 10. PWM Dimming Linearity

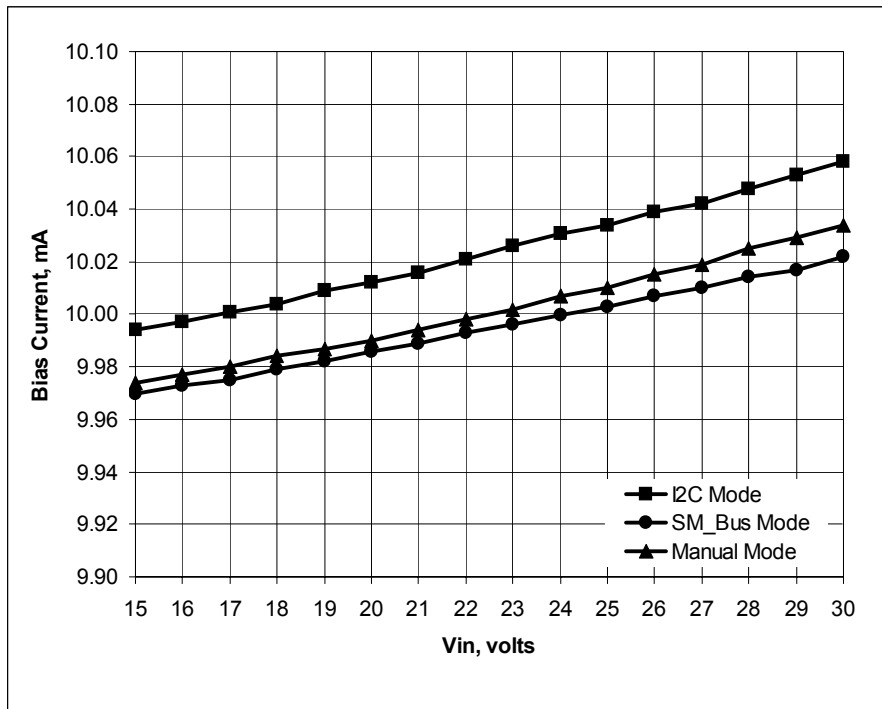

Figure 11. Bias Current vs Input Voltage (Operational Mode)



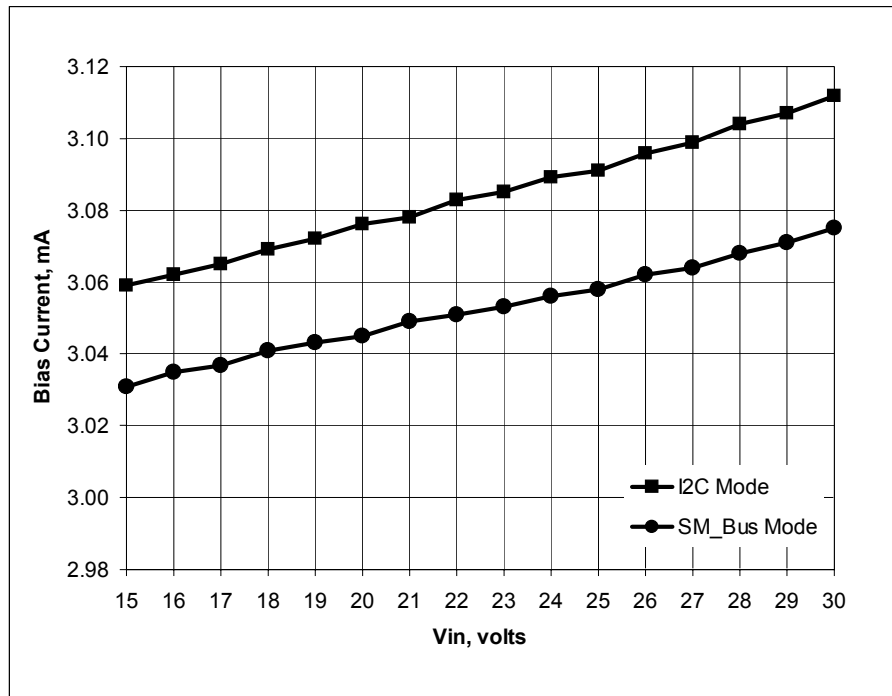

Figure 12. Bias Current vs Input Voltage (Sleep Mode)

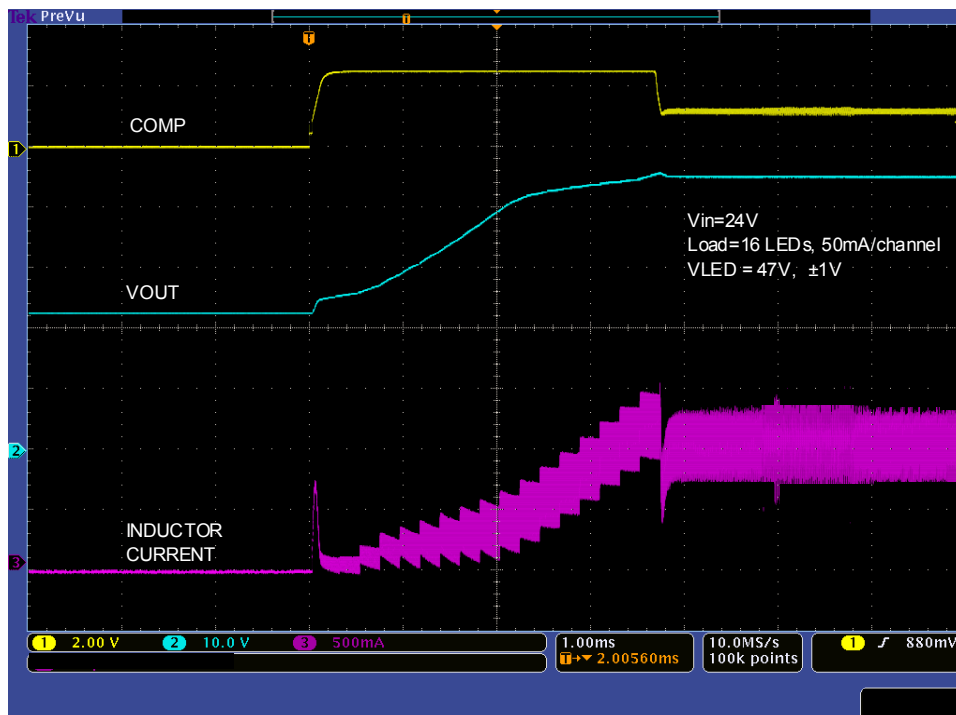

Figure 13. Boost Soft Start

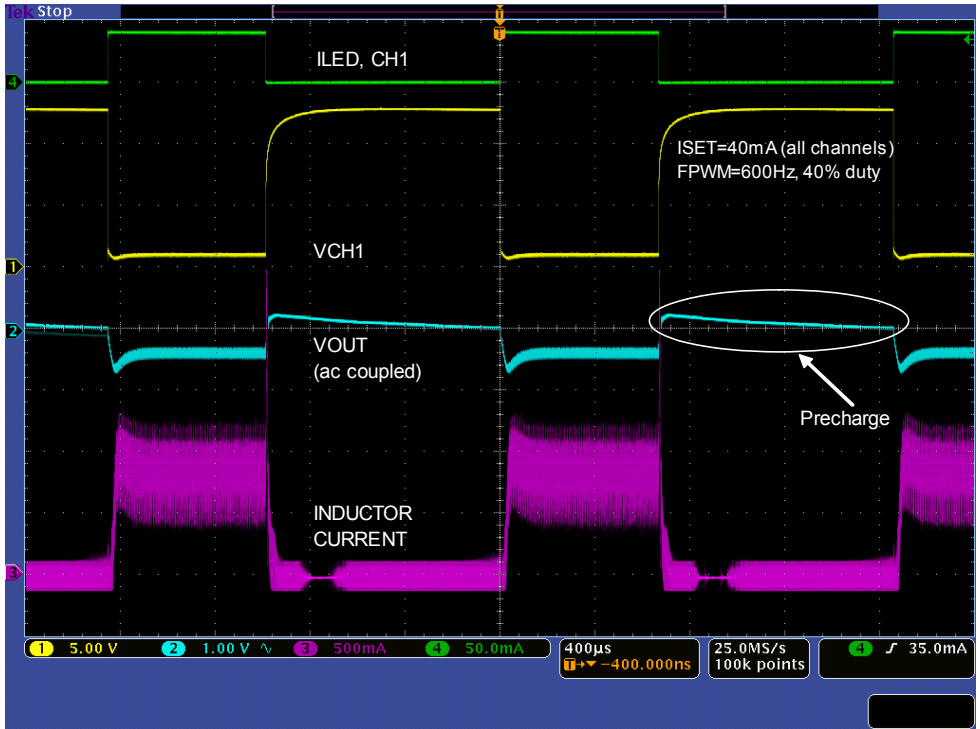

Figure 14. Typical Operation Waveforms for FPWM=600 Hz, 40% Duty

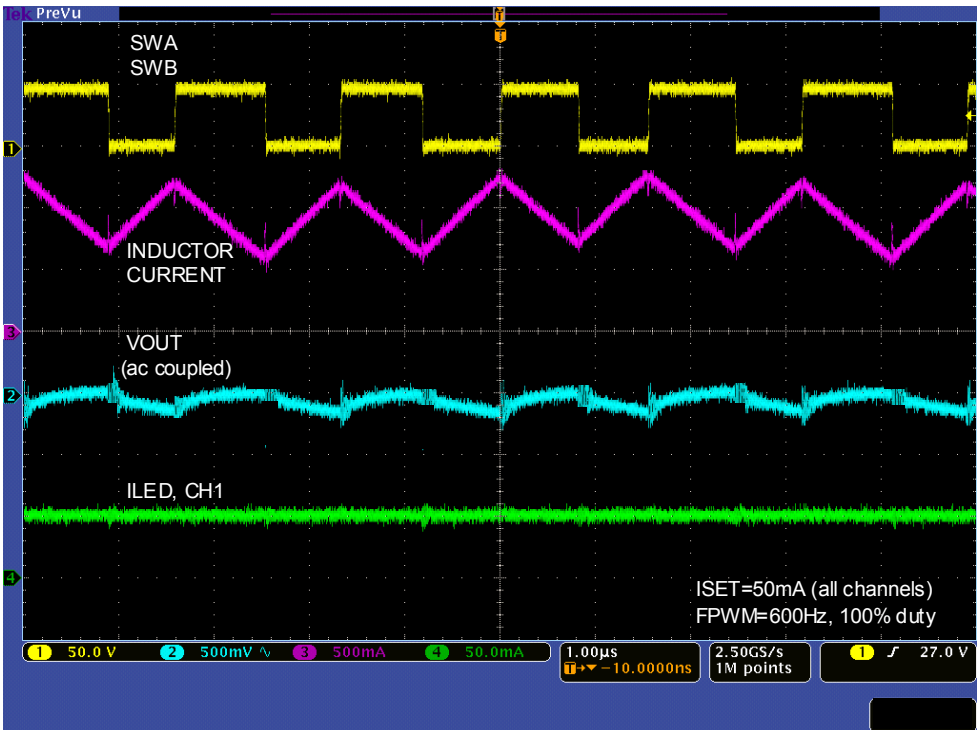

Figure 15. Typical Operation Waveforms for FPWM=600 Hz, 100% Duty

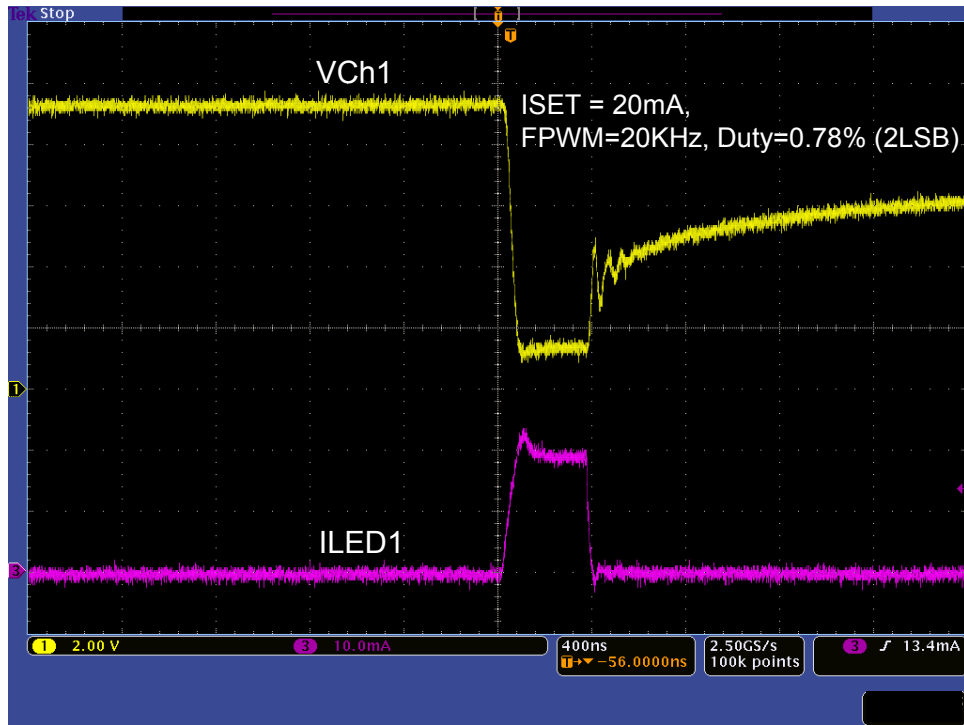

Figure 16. Low Duty Dimming Operation Waveforms (FPWM=20 kHz, 2LSB)

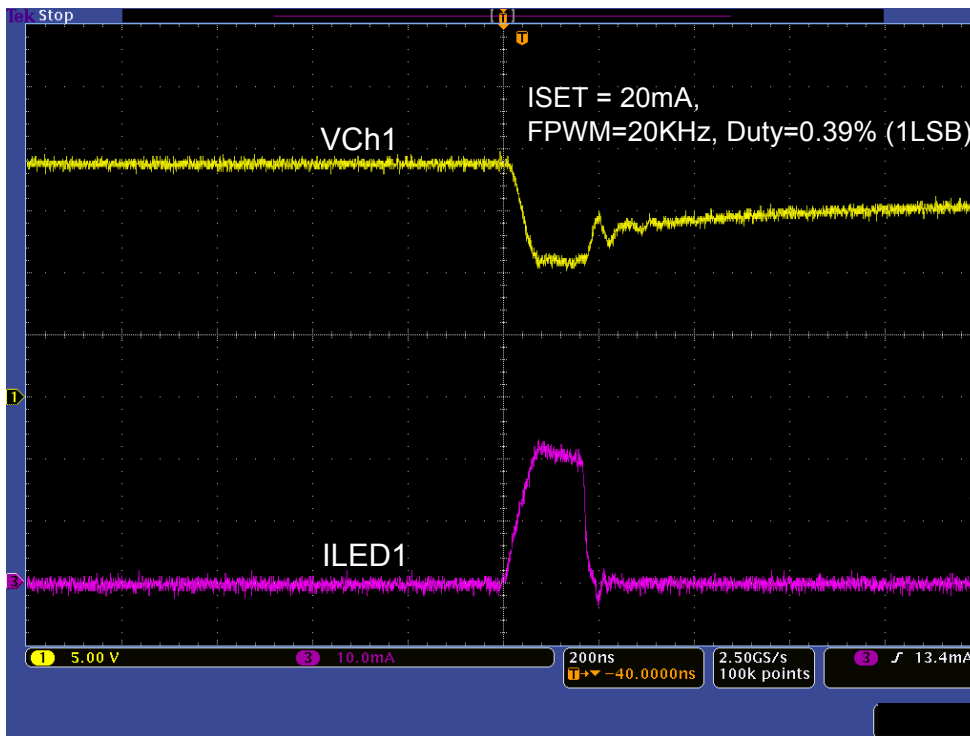

Figure 17. Low Duty Dimming Operation Waveforms (FPWM=20 kHz, 1LSB)

## TYPICAL APPLICATIONS

MANUAL MODE (Single Wire Control)

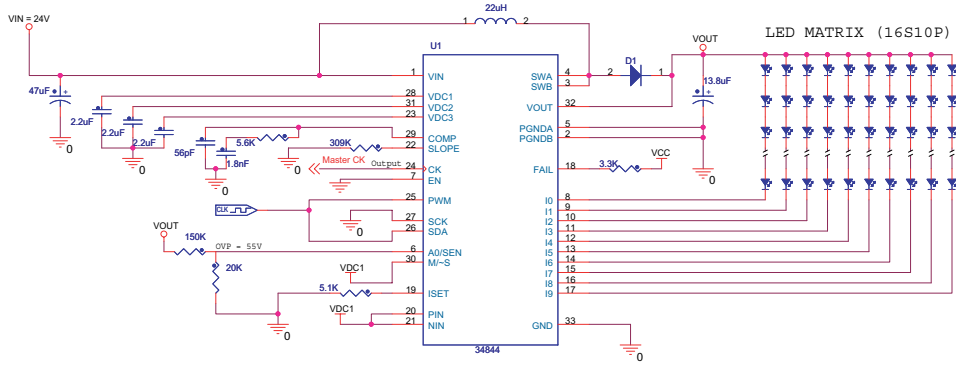

Figure 18. Manual Mode (Single Wire Control)

MANUAL MODE (Two Wire Control)

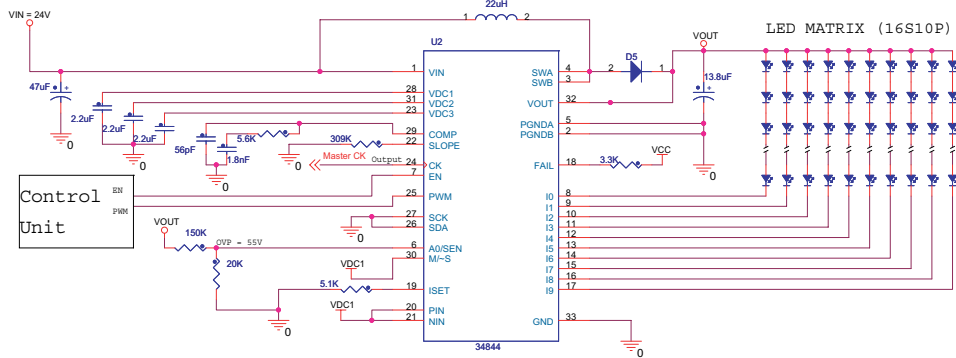

Figure 19. Manual Mode (Two Wire Control)

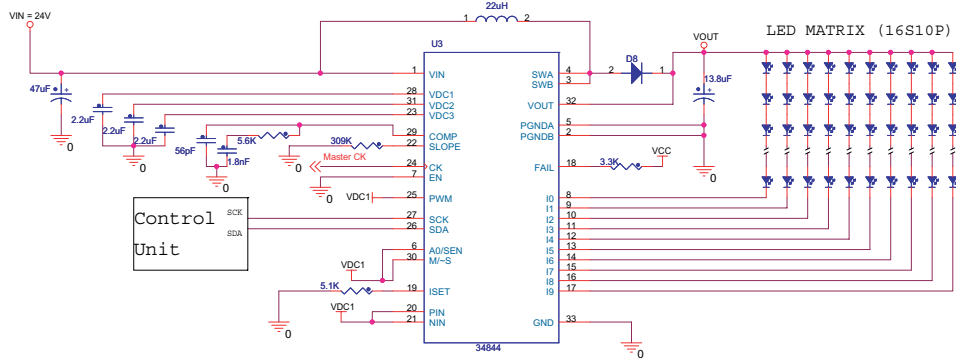

Figure 20. SM Bus Mode

MASTER - SLAVE Connection

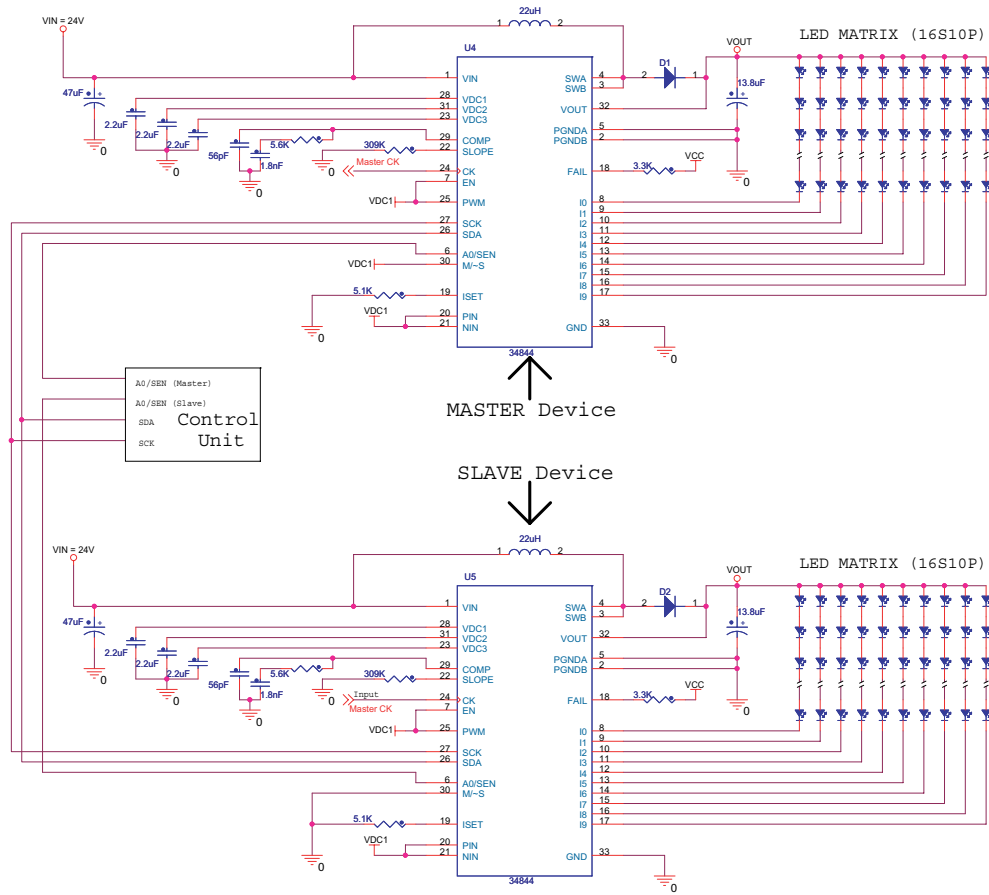

Figure 21. Master - Slave Connection

## COMPONENTS CALCULATION

The following formulas are intended for the calculation of all external components related with the Boost converter and Network compensation.

In order to calculate a Duty Cycle, the internal losses of the MOSFET and Diode should be taken into consideration.

$$D = \frac{V_{out} + V_D - V_{in}}{V_{out} + V_D - V_{SW}}$$

The average input current depends directly to the output current when the internal switch is off.

$$I_{in_{avg}} = \frac{I_{out}}{1 - D}$$

### Inductor

For calculating the Inductor we should consider the losses of the internal switch and winding resistance of the inductor.

$$L = \frac{(V_{in} - V_{SW} - (I_{in_{avg}} \times r_w)) \times D}{I_{in_{avg}} \times r \times F_{SW}}$$

It is important to look for an inductor rated at least for the maximum input current.

$$I_{in_{max}} = I_{in_{avg}} + \frac{V_{in} \times (V_{out} - V_{in})}{2 \times L \times F_{SW} \times V_{out}}$$

### Input Capacitor

The input capacitor should handle at least the following RMS current.

$$I_{rms_{Cin}} = \left( \frac{V_{in} \times (V_{out} - V_{in})}{2 \times L \times F_{SW} \times V_{out}} \right) \times 0.3$$

### Output Capacitor

For the output capacitor selection the internal current sense gain (CSG) and the Transconductance should be taken in consideration.

The CSG is the internal  $R_{Sense}$  times the current sense amplifier gain ( $A_{CSA}$ ).

$$CSG = A_{CSA} \times R_{Sense}$$

$$C_{out} = \frac{R_{Comp} \times 5 \times G_M \times I_{out} \times L}{(1 - D) \times V_{out} \times CSG}$$

The output voltage ripple ( $\Delta V_{out}$ ) depends on the ESR of the Output capacitor, for a low output voltage ripple it is recommended to use Ceramic capacitors that usually have very low ESR. Since ceramic capacitor are expensive, Electrolytic or Tantalum capacitors can be mixed with ceramic capacitors to have a cheaper solution.

$$ESR_{C_{out}} = \frac{V_{out} \times \Delta V_{out} \times F_{SW} \times L}{V_{out} \times (1 - D)}$$

The output capacitor should handle at least the following RMS current.

### Network Compensation

Since this Boost converter is current controlled, Type II compensation is needed.

$$I_{rms_{C_{out}}} = I_{out} \times \sqrt{\frac{D}{1 - D}}$$

In order to calculate the Network Compensation, first we need to calculate all Boost Converter components.

For this type of compensations we need to push out the Right Half Plane Zero to higher frequencies where it can't affect the overall loop significantly.

$$f_{RHPZ} = \frac{V_{out} \times (1 - D)^2}{I_{out} \times 2 \times \pi \times L}$$

The Crossover frequency must be set much lower than the location of the Right half plane zero

$$f_{Cross} = \frac{f_{RHPZ}}{5}$$

Since our system has a fixed Slope compensation set by  $R_{SLOPE}$ ,  $R_{Comp}$  should be fixed for all configurations.

$$R_{Comp} = 5.6Kohm$$

$C_{Comp1}$  and  $C_{Comp2}$  should be calculated as follows:

$$C_{Comp1} = \frac{2}{f_{Cross} \times R_{Comp} \times \pi \times 2}$$

$$C_{Comp2} = \frac{G_M}{6.28 \times F_{SW}}$$

### Slope Compensation

Slope Compensation can be expressed either in terms of Amperes/Second or as Volts/Second, through the use of the transfer resistance.

The following formula express the Slope Compensation in terms of V/μs:

$$V_{SLOPE} = \frac{(V_{out} - V_{in}) \times CSG}{L \times 2}$$

Where "L" is in μH

In order to have this slope compensation, the following resistor should be set.

$$R_{SLOPE} = \frac{33 \times 10^3}{V_{SLOPE}}$$

### Variable Definition

D= Boost Duty Cycle

Vout= Output Voltage

V<sub>D</sub>= Diode Forward Voltage

Vin= Input Voltage

V<sub>SW</sub>= V<sub>DROP</sub> of Internal Switch

ΔVout= Output Voltage Ripple Ratio

I<sub>in\_avg</sub>= Average Input Current

I<sub>out</sub>= Output Current

r=Input Current Ratio

I<sub>in\_max</sub>= Maximum input current

I<sub>rms\_Cin</sub>= RMS current for Input Capacitor

I<sub>rms\_Cout</sub>= RMS current for Output Capacitor

L= Inductor

r<sub>w</sub>= Inductor winding DC Resistance

F<sub>SW</sub>= Boost Switching Frequency

CSG= Current Sense Gain = 0.2 V/A

A<sub>CSA</sub>= Current Sense Amplifier Gain = 9

R<sub>Sense</sub>= Current Sense Resistor = 22mohm

C<sub>out</sub>= Output Capacitor

R<sub>Comp</sub>= Compensation Resistor

G<sub>M</sub>= OTA Transconductance

ESR<sub>Cout</sub>= ESR of Output Capacitor

f<sub>RHPZ</sub>= Right Half Plane Zero Frequency

f<sub>Cross</sub>= Crossover Frequency

C<sub>Comp1</sub>= Compensation Capacitor

C<sub>Comp2</sub>= Shunt Compensation Capacitor

V<sub>SLOPE</sub>= Slope Compensation (V/μs)

R<sub>SLOPE</sub>= External Resistor for Slope Compensation

## LAYOUT GUIDELINES

### RECOMMENDED STACK-UP

The following table shows the recommended layer stack-up for the signals to have good shielding and Thermal Dissipation.

Table 8. Layer Stacking Recommendations

	Stack-Up
Layer 1 (Top)	Signal
Layer 2 (Inner 1)	Ground
Layer 3 (Inner 2)	Signal
Layer 4 (Bottom)	Ground

### DECOUPLING CAPS

It is recommended to place decoupling caps of 100 pf at the beginning and at the end of any power signal traces to filter high frequency noise.

Decoupling caps of 100 pf should be also placed at the end of any long trace to cancel antenna effects on it.

These caps should be located as closed as possible to the point to be decoupled and the connection to GND should be as short as possible.

### SM-BUS/I2C COMMUNICATION AND CLOCK SIGNALS (SDA, SCK AND CK)

To avoid contamination of these signals by nearby high power or high frequency signals, it is a good practice to shield them with ground planes placed on adjacent layers. Make sure the ground plane is uniform through the whole signal trace length.

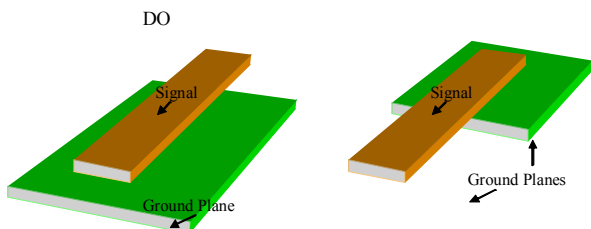

Figure 22. Recommended shielding for critical signals.

These signals shall not run parallel to power signals or other clock signals in the same routing layer. If they have to

cross or to be routed close to a power signal, it is a good practice to trace them perpendicularly or at 45° on a different layer to avoid coupling noise.

### SWITCHING NODE (SWA & SWB)

The components associated to this node must be placed as close as possible to each other to keep the switching loop small enough so that it does not contaminate other signals. However, care must be taken to ensure the copper traces used to connect these components together on this node are capable to handle the necessary current and voltage.

As a reference, a 10 mils trace with a thickness of 1.0 oz. of copper is capable of handling one ampere.

Traces for connecting the inductor, input and output caps should be as wide and short as possible to avoid adding inductance or resistance to the loop. The placement of these components should be selected far away from sensitive signals like compensation, feedback and internal regulators to avoid power noise coupling.

### COMPENSATION COMPONENTS

Components related with COMP pin need to be placed as close as possible to the pin.

### FEEDBACK SIGNAL

The trace of the feedback signal (VOUT) should be routed perpendicularly or at 45° on a different layer to avoid coupling noise, preferably between ground or power planes.

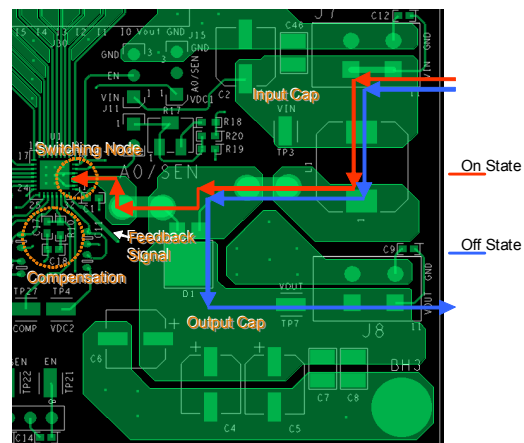

Figure 23. Feedback Signal Tracing



# PACKAGING

## PACKAGE DIMENSIONS

For the most current package revision, visit [www.freescale.com](http://www.freescale.com) and perform a keyword search using the "98A" listed below.

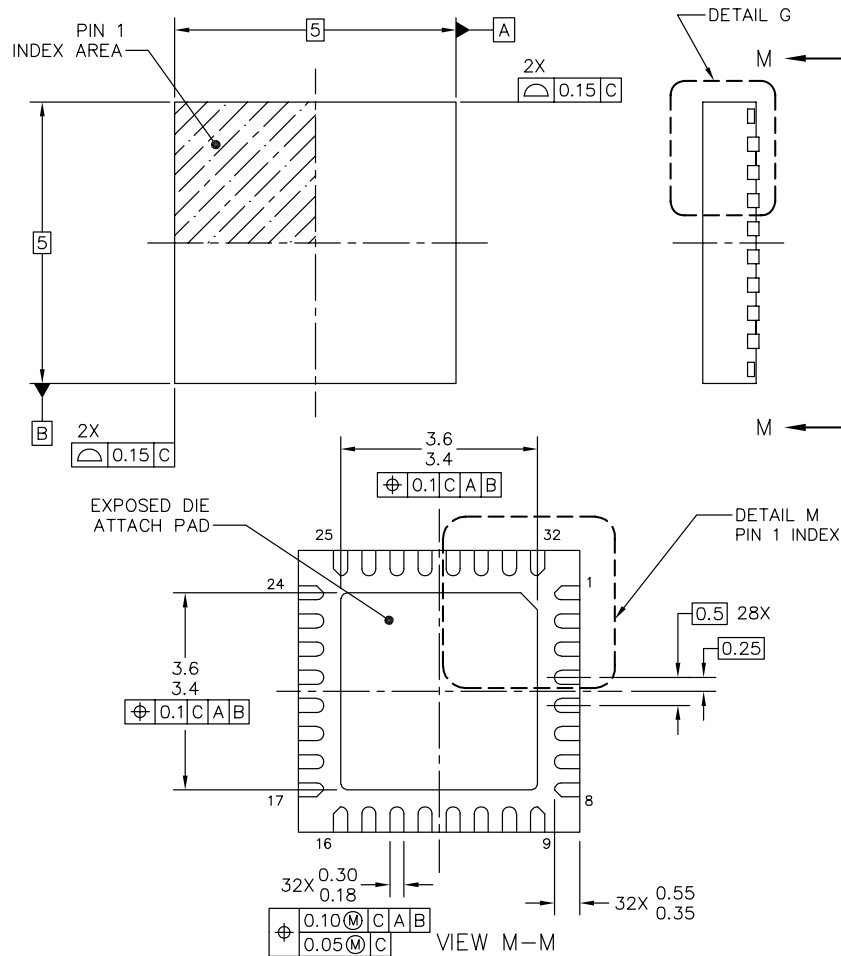

© FREESCALE SEMICONDUCTOR, INC. ALL RIGHTS RESERVED.	<b>MECHANICAL OUTLINE</b>	PRINT VERSION NOT TO SCALE	
TITLE: THERMALLY ENHANCED QUAD FLAT NON-LEADED PACKAGE (QFN) 32 TERMINAL, 0.50 PITCH (5 X 5 X 1) 3.5 X 3.5 EP, CASE OUTLINE	DOCUMENT NO: 98ASA10800D	REV: 0	
	CASE NUMBER: 1972-01	29 AUG 2007	
	STANDARD: NON-JEDEC		

**EP SUFFIX**  
32-PIN  
98ASA10800D  
REVISION O

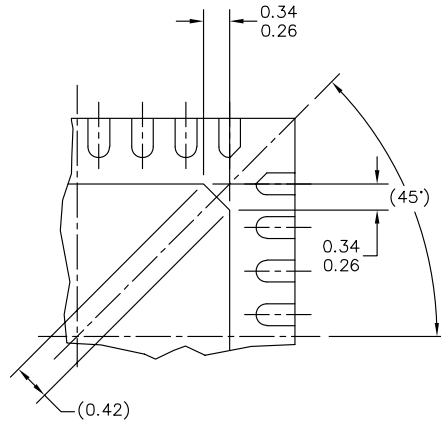

DETAIL M  
PIN 1 BACKSIDE IDENTIFIER

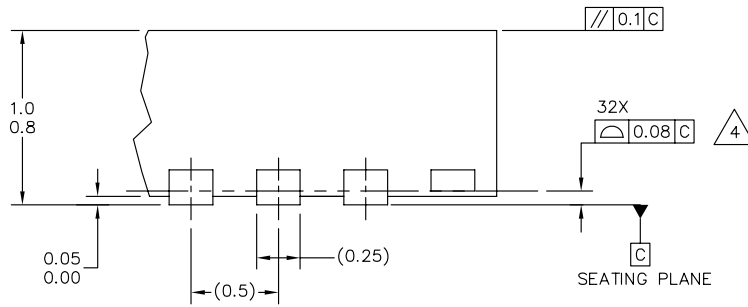

DETAIL G  
VIEW ROTATED 90° CW

© FREESCALE SEMICONDUCTOR, INC. ALL RIGHTS RESERVED.	<b>MECHANICAL OUTLINE</b>	PRINT VERSION NOT TO SCALE	
TITLE: THERMALLY ENHANCED QUAD FLAT NON-LEADED PACKAGE (QFN) 32 TERMINAL, 0.50 PITCH (5 X 5 X 1) 3.5 X 3.5 EP, CASE OUTLINE	DOCUMENT NO: 98ASA10800D	REV: 0	
	CASE NUMBER: 1972-01	29 AUG 2007	
	STANDARD: NON-JEDEC		

**EP SUFFIX**  
32-PIN  
98ASA10800D  
REVISION O

NOTES:

1. ALL DIMENSIONS ARE IN MILLIMETERS.
2. DIMENSIONING AND TOLERANCING PER ASME Y14.5M-1994.
3. RADIUS ON TERMINAL IS OPTIONAL.
4.  COPLANARITY APPLIES TO LEADS, AND DIE ATTACH PAD.
5. MINIMUM METAL GAP SHOULD BE 0.2 MM.

© FREESCALE SEMICONDUCTOR, INC. ALL RIGHTS RESERVED.	<b>MECHANICAL OUTLINE</b>	PRINT VERSION NOT TO SCALE	
TITLE: THERMALLY ENHANCED QUAD FLAT NON-LEADED PACKAGE (QFN) 32 TERMINAL, 0.50 PITCH (5 X 5 X 1) 3.5 X 3.5 EP, CASE OUTLINE	DOCUMENT NO: 98ASA10800D	REV: 0	
	CASE NUMBER: 1972-01	29 AUG 2007	
	STANDARD: NON-JEDEC		

**EP SUFFIX**  
32-PIN  
98ASA10800D  
REVISION O

**REVISION HISTORY**

REVISION	DATE	DESCRIPTION OF CHANGES
3.0	11/2008	<ul style="list-style-type: none"><li>• Initial Release</li></ul>
4.0	3/2009	<ul style="list-style-type: none"><li>• Added PWM Pin to Maximum Voltages in Maximum Rating Table.</li><li>• Added Disabling LED Channels</li><li>• Rewrote Fail Pin section</li><li>• Added I2C Bus Specification</li></ul>
5.0	5/2009	<ul style="list-style-type: none"><li>• Corrected Compensasion Components paragraph on page 32.</li></ul>

## **How to Reach Us:**

### **Home Page:**

[www.freescale.com](http://www.freescale.com)

### **Web Support:**

<http://www.freescale.com/support>

### **USA/Europe or Locations Not Listed:**

Freescale Semiconductor, Inc.  
Technical Information Center, EL516  
2100 East Elliot Road  
Tempe, Arizona 85284  
1-800-521-6274 or +1-480-768-2130  
[www.freescale.com/support](http://www.freescale.com/support)

### **Europe, Middle East, and Africa:**

Freescale Halbleiter Deutschland GmbH  
Technical Information Center  
Schatzbogen 7  
81829 Muenchen, Germany  
+44 1296 380 456 (English)  
+46 8 52200080 (English)  
+49 89 92103 559 (German)  
+33 1 69 35 48 48 (French)  
[www.freescale.com/support](http://www.freescale.com/support)

### **Japan:**

Freescale Semiconductor Japan Ltd.  
Headquarters  
ARCO Tower 15F  
1-8-1, Shimo-Meguro, Meguro-ku,  
Tokyo 153-0064  
Japan  
0120 191014 or +81 3 5437 9125  
[support.japan@freescale.com](mailto:support.japan@freescale.com)

### **Asia/Pacific:**

Freescale Semiconductor China Ltd.  
Exchange Building 23F  
No. 118 Jianguo Road  
Chaoyang District  
Beijing 100022  
China  
+86 10 5879 8000  
[support.asia@freescale.com](mailto:support.asia@freescale.com)

### **For Literature Requests Only:**

Freescale Semiconductor Literature Distribution Center  
P.O. Box 5405  
Denver, Colorado 80217  
1-800-441-2447 or +1-303-675-2140  
Fax: +1-303-675-2150  
[LDCForFreescaleSemiconductor@hibbertgroup.com](mailto:LDCForFreescaleSemiconductor@hibbertgroup.com)

Information in this document is provided solely to enable system and software implementers to use Freescale Semiconductor products. There are no express or implied copyright licenses granted hereunder to design or fabricate any integrated circuits or integrated circuits based on the information in this document.

Freescale Semiconductor reserves the right to make changes without further notice to any products herein. Freescale Semiconductor makes no warranty, representation or guarantee regarding the suitability of its products for any particular purpose, nor does Freescale Semiconductor assume any liability arising out of the application or use of any product or circuit, and specifically disclaims any and all liability, including without limitation consequential or incidental damages. "Typical" parameters that may be provided in Freescale Semiconductor data sheets and/or specifications can and do vary in different applications and actual performance may vary over time. All operating parameters, including "Typicals", must be validated for each customer application by customer's technical experts. Freescale Semiconductor does not convey any license under its patent rights nor the rights of others. Freescale Semiconductor products are not designed, intended, or authorized for use as components in systems intended for surgical implant into the body, or other applications intended to support or sustain life, or for any other application in which the failure of the Freescale Semiconductor product could create a situation where personal injury or death may occur. Should Buyer purchase or use Freescale Semiconductor products for any such unintended or unauthorized application, Buyer shall indemnify and hold Freescale Semiconductor and its officers, employees, subsidiaries, affiliates, and distributors harmless against all claims, costs, damages, and expenses, and reasonable attorney fees arising out of, directly or indirectly, any claim of personal injury or death associated with such unintended or unauthorized use, even if such claim alleges that Freescale Semiconductor was negligent regarding the design or manufacture of the part.



Freescale™ and the Freescale logo are trademarks of Freescale Semiconductor, Inc. All other product or service names are the property of their respective owners.

© Freescale Semiconductor, Inc. 2009. All rights reserved.

MC34844  
Rev. 5.0  
5/2009