

Silicon NPN Power Transistors

2SD1439

DESCRIPTION

- With TO-3PN package
- Built-in damper diode
- High voltage ,high reliability
- High speed switching
- Wide area of safe operation

APPLICATIONS

- For horizontal deflection output applications

PINNING

PIN	DESCRIPTION
1	Base
2	Collector;connected to mounting base
3	Emitter

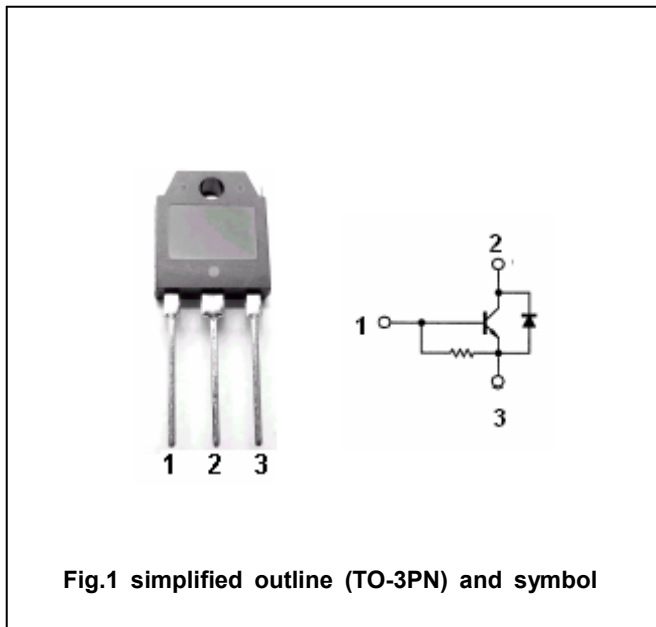

Fig.1 simplified outline (TO-3PN) and symbol

Absolute maximum ratings (Ta=25°C)

SYMBOL	PARAMETER	CONDITIONS	VALUE	UNIT
V <sub>CBO</sub>	Collector-base voltage	Open emitter	1500	V
V <sub>EBO</sub>	Emitter-base voltage	Open collector	5	V
I <sub>C</sub>	Collector current (DC)		3	A
I <sub>CM</sub>	Collector current (Pulse)		10	A
I <sub>BM</sub>	Base current (Pulse)		3.5	A
P <sub>C</sub>	Collector power dissipation	T <sub>C</sub> =25°C	50	W
T <sub>j</sub>	Junction temperature		130	°C
T <sub>stg</sub>	Storage temperature		-55~130	°C

## Silicon NPN Power Transistors

2SD1439

## CHARACTERISTICS

T<sub>j</sub>=25 °C unless otherwise specified

SYMBOL	PARAMETER	CONDITIONS	MIN	TYP.	MAX	UNIT
V <sub>(BR)EBO</sub>	Emitter-base breakdown voltage	I <sub>E</sub> =500mA; I <sub>C</sub> =0	5			V
V <sub>CEsat</sub>	Collector-emitter saturation voltage	I <sub>C</sub> =2A; I <sub>B</sub> =0.75A			5.0	V
V <sub>BEsat</sub>	Base-emitter saturation voltage	I <sub>C</sub> =2A; I <sub>B</sub> =0.75A			1.5	V
I <sub>CB0</sub>	Collector cut-off current	V <sub>CB</sub> =750V; I <sub>E</sub> =0			50	μA
I <sub>CB0</sub>	Collector cut-off current	V <sub>CB</sub> =1500V; I <sub>E</sub> =0			1	mA
h <sub>FE</sub>	DC current gain	I <sub>C</sub> =2A ; V <sub>CE</sub> =10V	4		12	
t <sub>s</sub>	Storage time	I <sub>C</sub> =2A I <sub>Bend</sub> =0.75A, L <sub>Leak</sub> =5μH			7.0	μs
t <sub>f</sub>	Fall time				0.75	μs
V <sub>F</sub>	Diode forward voltage	I <sub>F</sub> =-4A, I <sub>B</sub> =0			2.2	V

Silicon NPN Power Transistors

2SD1439

PACKAGE OUTLINE

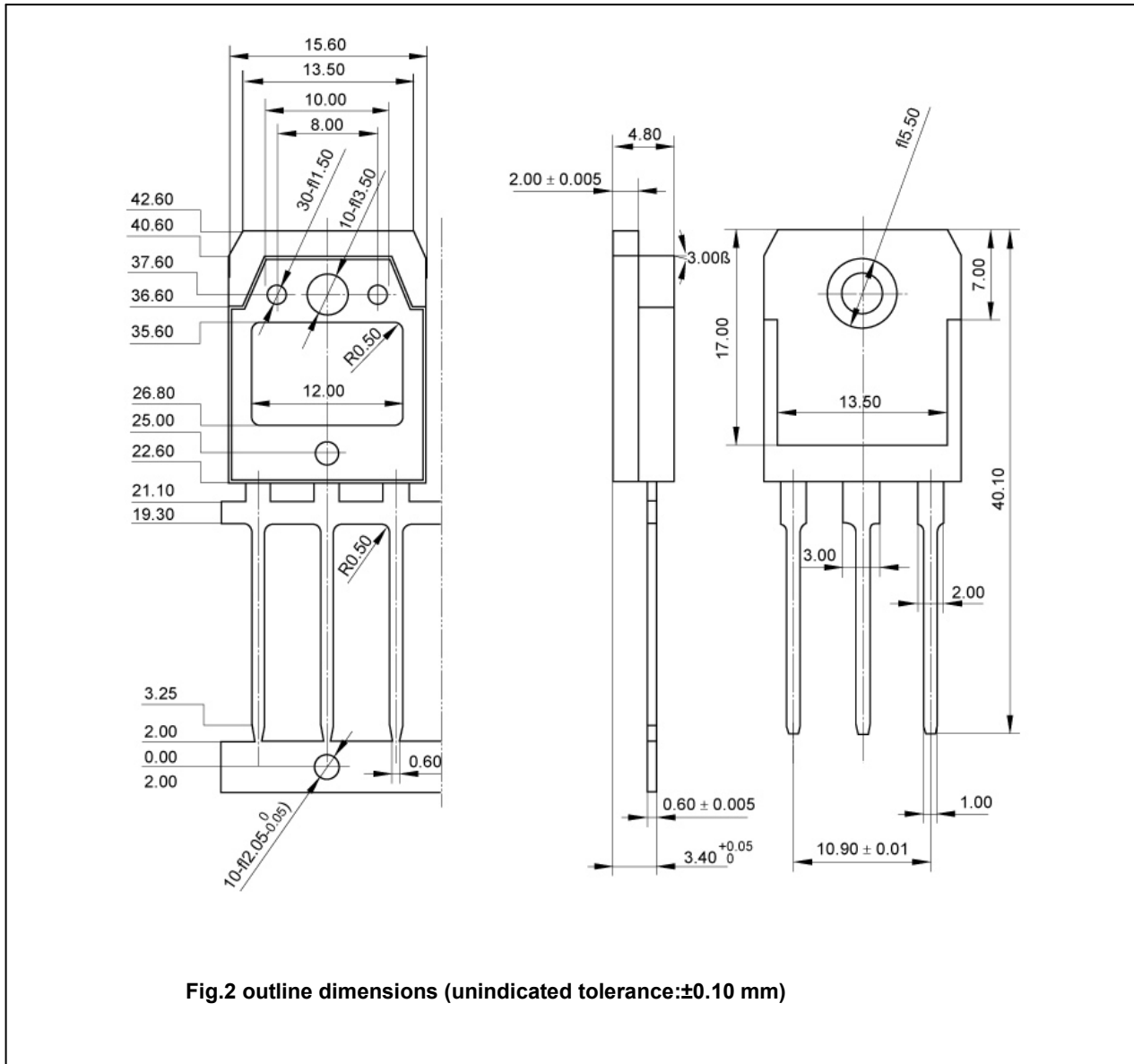

Fig.2 outline dimensions (unindicated tolerance:±0.10 mm)