

OVERVIEW

The SM1125ABV is melody IC fabricated in NPC's Molybdenum-gate CMOS for use in mobile telecommunications equipment.

FEATURES

- 12 melodies selectable
- Level hold playback mode
- Built-in oscillator circuit
 - Oscillator frequency: 38.4kHz
- 2-pin serial data melody selection and 1-pin melody playback control
- Power save function
 - Oscillator stopped in no-play modes
- Molybdenum-gate CMOS process
- 8-pin plastic VSOP package

ORDERING INFORMATION

Device	Package
SM1125ABV	8-pin VSOP

PINOUT

(Top view)

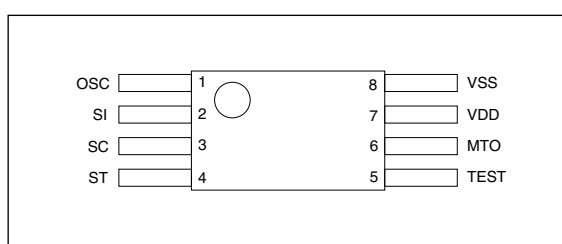

PACKAGE DIMENSIONS

(Unit: mm)

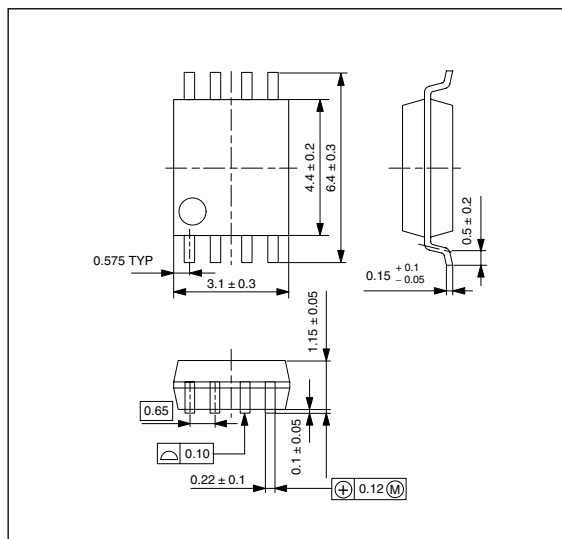

BLOCK DIAGRAM

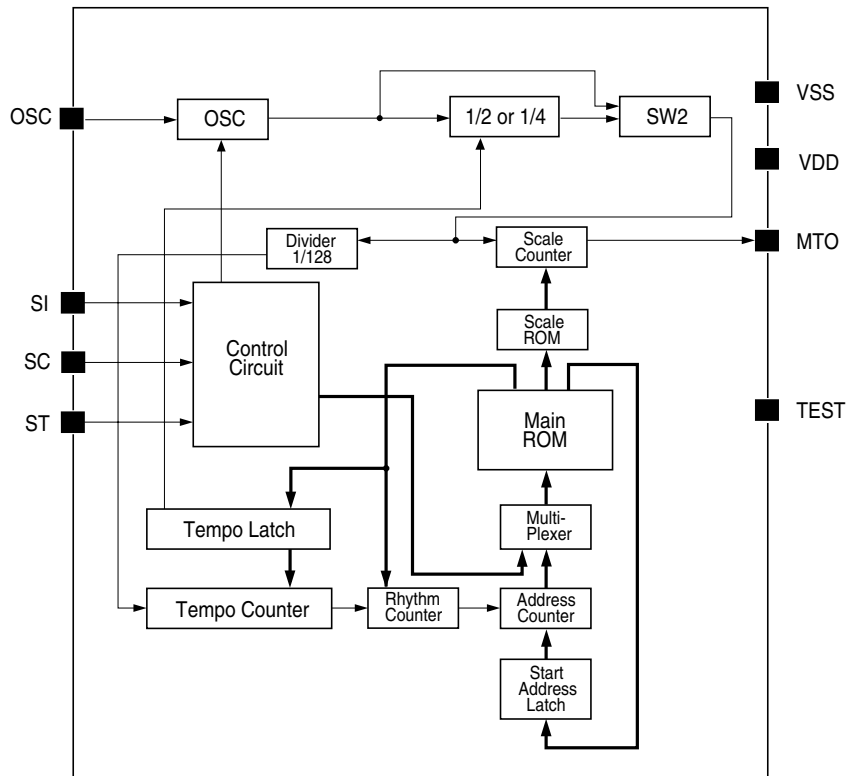

PIN DESCRIPTION

Number	Name	I/O	Function
1	OSC	I	External resistor and capacitor connection pins
2	SI	I	Playback control serial interface data input
3	SC	I	Playback control serial interface clock input
4	ST	I	Playback start/stop control signal input
5	TEST	I	Test input pin. Leave open or tie to VSS. (pull-down resistance built-in)
6	MTO	O	Playback melody signal output
7	VDD	-	Supply pin (+)
8	VSS	-	Ground pin

SPECIFICATIONS

Absolute Maximum Ratings

Parameter	Symbol	Condition	Rating	Unit
Supply voltage range	$V_{DD} - V_{SS}$		- 0.3 to 5.0	V
Input voltage range	V_{IN}		$V_{SS} - 0.2$ to $V_{DD} + 0.2$	V
Power dissipation	P_D		100	mW
Storage temperature range	T_{stg}		- 40 to 125	°C

Recommended Operating Conditions

$V_{SS} = 0V$

Parameter	Symbol	Condition	Rating	Unit
Supply voltage	V_{DD}		2.0 to 3.6	V
Operating temperature	T_{opr}		-20 to 70	°C

DC Characteristics

Unless otherwise noted $T_a = -20$ to 70°C , $V_{SS} = 0V$, $V_{DD} = 2.0$ to $3.6V$

Parameter	Symbol	Condition	Rating			Unit
			min	typ	max	
Supply voltage	V_{DD}		2.0	3.0	3.6	V
Current consumption (1)	I_{DD1}	Non-playback mode, $T_a = 25^\circ\text{C}$	-	-	0.5	μA
Current consumption (2)	I_{DD2}	Playback mode, MTO pin open	-	215	600	μA
Input voltage	V_{IH}	ST, SI, SC pins	$V_{DD} - 0.2$	-	V_{DD}	V
	V_{IL}		V_{SS}	-	$V_{SS} + 0.2$	V
Input current (1)	I_{IH1}	ST, SI, SC pins, $V_{IH} = V_{DD}$, $T_a = 25^\circ\text{C}$	-	-	0.5	μA
	I_{IL1}	ST, SI, SC pins, $V_{IL} = 0V$, $T_a = 25^\circ\text{C}$	-	-	0.5	μA
Input current (2)	I_{IH2}	TEST pin, $V_{IH} = V_{DD}$	-	-	200	μA
Open voltage	V_{OPN}	TEST pin	-	-	0.1	V
Output voltage	V_{OH}	MTO pin, $I_{OH} = 1\text{mA}$	$V_{DD} - 0.4$	-	V_{DD}	V
	V_{OL}	MTO pin, $I_{OL} = 1\text{mA}$	V_{SS}	-	$V_{SS} + 0.4$	V
Oscillator frequency	f_{OSC}	NPC test board measurement, $R_O = 91\text{k}\Omega$, $C_O = 200\text{pF}$, $V_{DD} = 2.0$ to $3.6V$	34.5	38.4	42.5	kHz
Frequency stability	$\Delta f/f$		-	0.1	-	%/0.1V
Oscillator start voltage	V_{DOB}		-	-	1.6	V
Oscillator stop voltage	V_{DOS}		-	-	1.6	V

AC Characteristics

Unless otherwise noted $T_a = -20$ to 70°C , $V_{SS} = 0\text{V}$, $V_{DD} = 2.0$ to 3.6V

Parameter	Symbol	Condition	Rating			Unit
			min	typ	max	
SC pulse cycle	t_{SC}	"SC input pulse" timing	5.0	-	-	μs
SC HIGH-level pulsewidth	t_{SWH}		2.0	-	-	μs
SC LOW-level pulsewidth	t_{SWL}		2.0	-	-	μs
SC pulse rise time	t_{Sr}		-	-	200	ns
SC pulse fall time	t_{Sf}		-	-	200	ns
SI-SC setup time	t_{DS}	"SC-SI serial input pulse" timing	2.0	-	-	μs
SI-SC hold time	t_{DH}		2.0	-	-	μs

SC input pulse

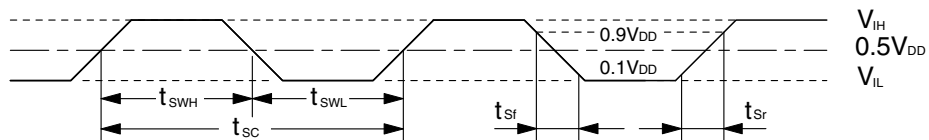

SC-SI serial input pulse

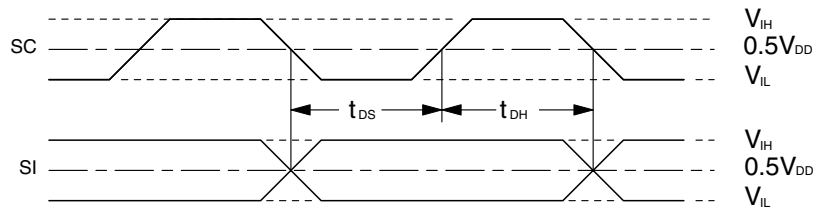

FUNCTIONAL DESCRIPTION

Control Functions

Reference clock

SM1125ABV has built-in RC oscillator circuit (oscillation frequency: 38.4kHz typ).

Power-saving function

The built-in RC oscillator is stopped when not in playback mode (when ST is LOW), preventing unwanted current flow.

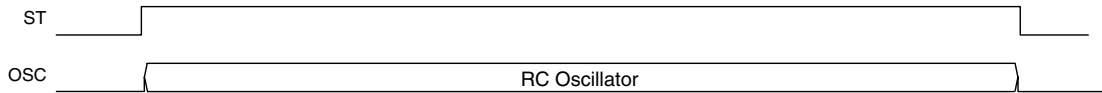
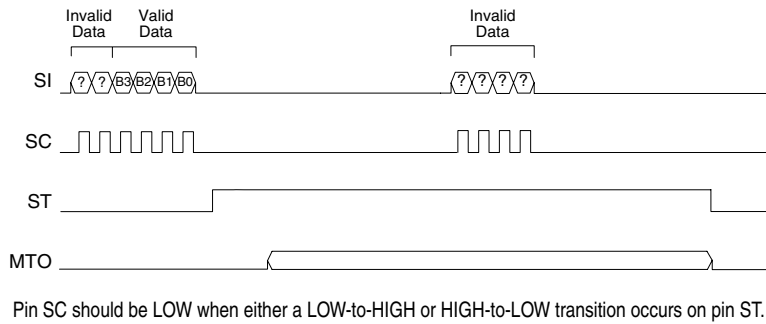

Figure 1. Oscillator circuit operation

Playback control

The ST pin controls the start of playback. While ST is HIGH, the melody is played repeatedly, and when ST goes LOW, playback stops. Melodies are selected by input serial data on pins SI and SC, as shown in table 1. The final 4 serial data bits in any input data string form the valid selection data, and this data is retained even after playback. If serial data is input during playback, the data is ignored and playback continues.



Pin SC should be LOW when either a LOW-to-HIGH or HIGH-to-LOW transition occurs on pin ST.

Figure 2. Serial data input timing

Serial data selection

Table 1. Serial data melody select

B3	B2	B1	B0	ST	Melody
L	L	L	L	L → H	1st melody
L	L	L	H	L → H	2nd melody
L	L	H	L	L → H	3rd melody
L	L	H	H	L → H	4th melody
L	H	L	L	L → H	5th melody
L	H	L	H	L → H	6th melody

B3	B2	B1	B0	ST	Melody
L	H	H	L	L → H	7th melody
L	H	H	H	L → H	8th melody
H	L	L	L	L → H	9th melody
H	L	L	H	L → H	10th melody
H	L	H	L	L → H	11th melody
H	L	H	H	L → H	12th melody

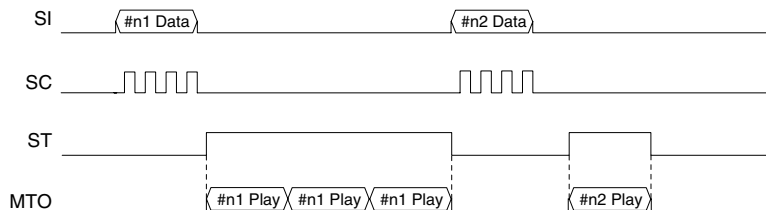

Melody plays repeatedly when ST is HIGH, and stops immediately when ST goes LOW.

Figure 3. Melody repetition timing

Playback timing diagrams

Playback start

Playback starts 128 ± 1 OSC clock cycles after ST goes HIGH.

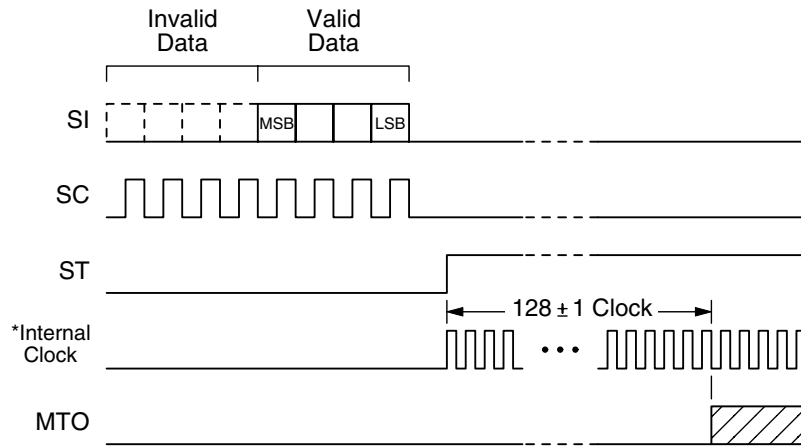

Figure 4. Start timing

Playback stop

Playback stops immediately and the oscillator also stops when ST goes LOW.

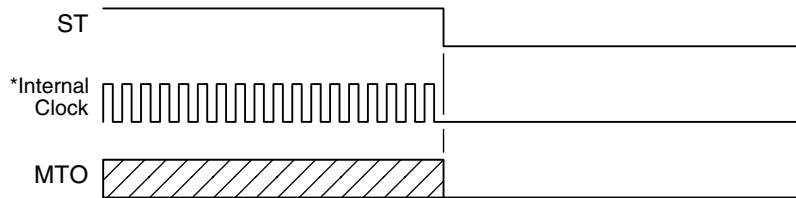
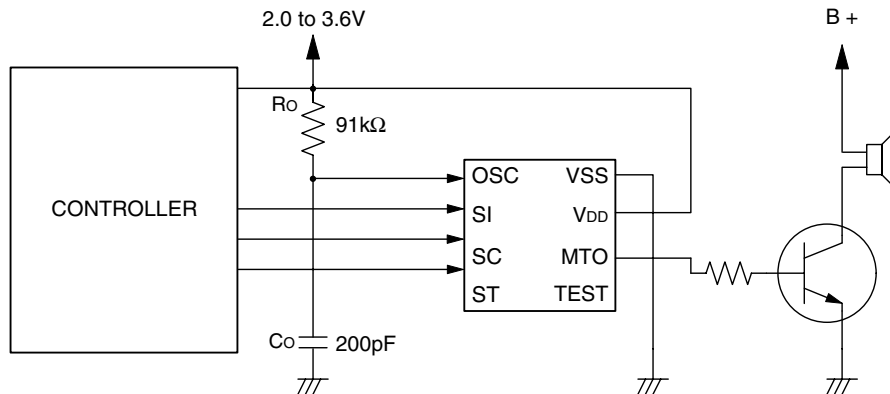

Figure 5. Stop timing

TYPICAL APPLICATION



OSCILLATOR FREQUENCY MEASUREMENT

The measurement circuit below shows a SM1125ABV with built-in RC oscillator circuit and external RC oscillator components capacitor C_O and resistor R_O .

When ST is switched to V_{DD} , the oscillator starts and outputs a pulse on MTO. The output pulse is counted using a frequency counter.

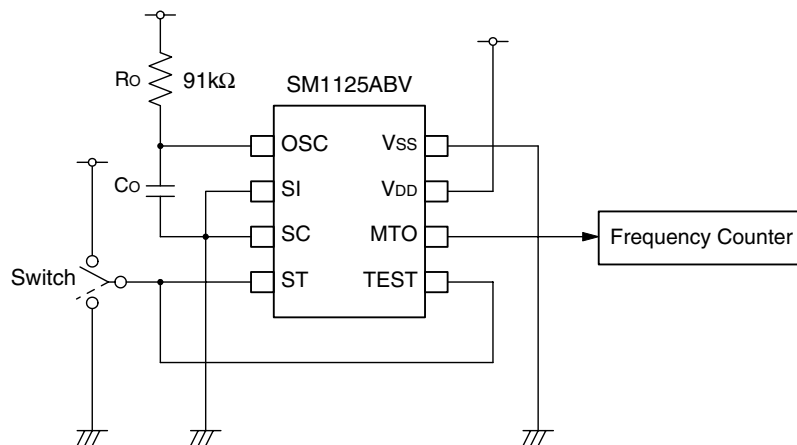

Note that the board mounting and wiring will marginally affect the output frequency, even for equivalent values for R_O and C_O .

SONG LIST

NPC performs all actions required by the copyright guidelines and rules laid down by the Japanese Society for Rights of Authors, Composers and Publishers (JASRAC). Accordingly, for products intended solely for sale within Japan, copyright permission is not required when submitting an order request, except in special circumstances.

For products intended for sale outside of Japan, it is the responsibility of the customer to obtain permission to use a melody by following all relevant copyright rules and regulations for the countries concerned. NPC does not undertake the copyright permission process for overseas countries.

SM1125ABV

Number	Song Title	Composer	Time [s]
1	Departure	Komuro Tetsuya	8.46
2	Mirai yosouzu II	Yoshida Miwa	19.4
3	Roman hikou	Komekome club	13.68
4	Namonaki uta	Sakurai Kazutoshi	21.03
5	Last Christmas	Michael George	18.14
6	We wish you a merry Christmas	–	9.78
7	Jingle Bells	–	15.56
8	Happy Birthday to you	Hill Mildred Junius Welch/Hill Patty Smith	12.17
9	Green Sleeves	–	17.63
10	Jesu joy of mans desiring	–	20.18
11	Mickey Mouse March	Dodd Jimmie	5.89
12	Its a small world	Sherman Richard M/Sherman Robert B	12.99

Note. The copyrights of music described in this list have been the public domain or being managed by JASRAC in Japan.

Please pay your attention to the following points at time of using the products shown in this document.

The products shown in this document (hereinafter "Products") are not intended to be used for the apparatus that exerts harmful influence on human lives due to the defects, failure or malfunction of the Products. Customers are requested to obtain prior written agreement for such use from SEIKO NPC CORPORATION (hereinafter "NPC"). Customers shall be solely responsible for, and indemnify and hold NPC free and harmless from, any and all claims, damages, losses, expenses or lawsuits, due to such use without such agreement. NPC reserves the right to change the specifications of the Products in order to improve the characteristic or reliability thereof. NPC makes no claim or warranty that the contents described in this document dose not infringe any intellectual property right or other similar right owned by third parties. Therefore, NPC shall not be responsible for such problems, even if the use is in accordance with the descriptions provided in this document. Any descriptions including applications, circuits, and the parameters of the Products in this document are for reference to use the Products, and shall not be guaranteed free from defect, inapplicability to the design for the mass-production products without further testing or modification. Customers are requested not to export or re-export, directly or indirectly, the Products to any country or any entity not in compliance with or in violation of the national export administration laws, treaties, orders and regulations. Customers are requested appropriately take steps to obtain required permissions or approvals from appropriate government agencies.

The logo for SEIKO NPC CORPORATION, consisting of the letters 'NPC' in a bold, black, sans-serif font.

SEIKO NPC CORPORATION

15-6, Nihombashi-kabutocho, Chuo-ku,
Tokyo 103-0026, Japan
Telephone: +81-3-6667-6601
Facsimile: +81-3-6667-6611
<http://www.npc.co.jp/>
Email: sales@npc.co.jp

NC0720AE 2008.08