

# 710-319 Composite Split Junction Fitting "Y" Configuration

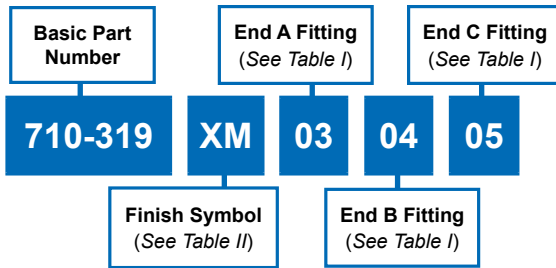

- ### APPLICATION NOTES
1. Metric dimensions (mm) are in parentheses and are for reference only.
  2. Transitions mate to 710S269, S270 and S271 adapters.
  3. When all ends are identical, insert only one dash number. When multiple dash numbers are ordered, transition size will be determined by the largest. Adapter may be supplied on smaller entries. Letter to follow entry will be supplied with adapters.

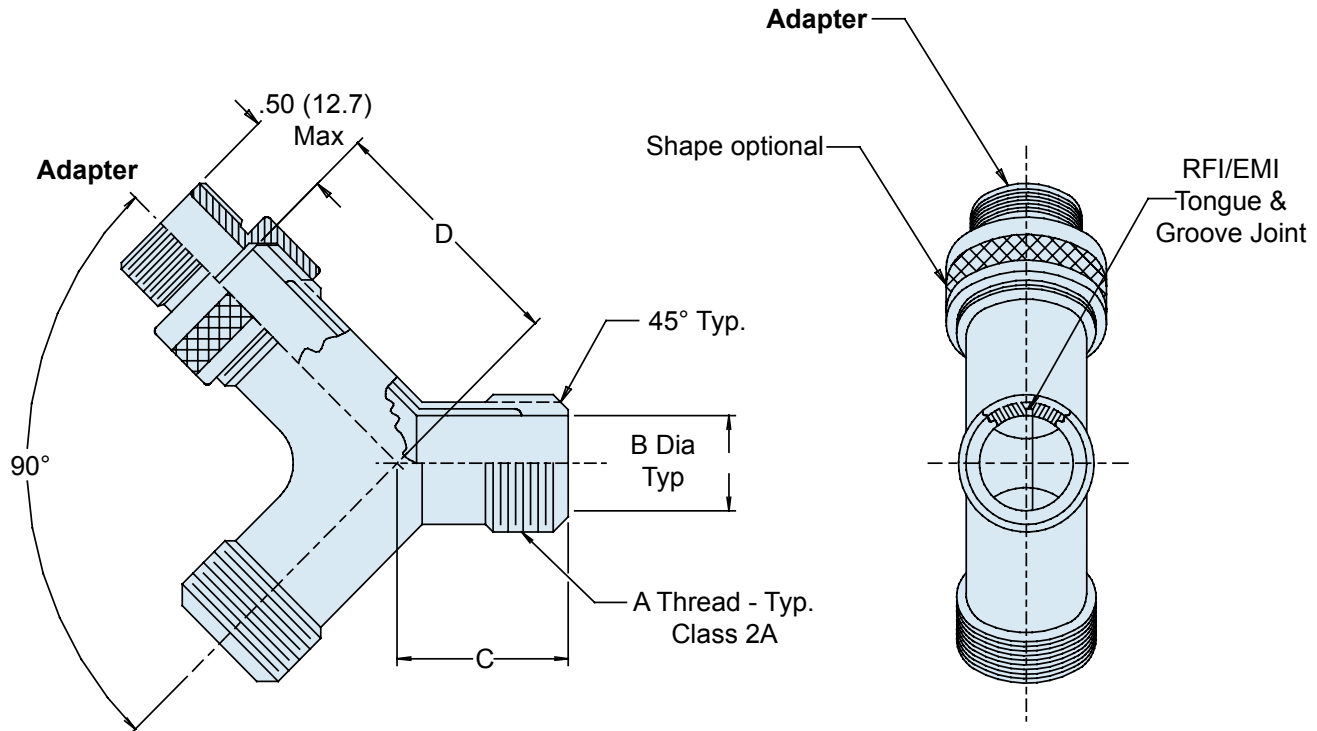

**TABLE I: END ORDER NUMBER AND DIMENSIONS**

End No.	A Thread		B Dia	C Max	D Max
	Unified				
01	.750 - 20		.500 (12.7)	1.312 (33.3)	1.312 (33.3)
02	1.000 - 20		.750 (19.1)	1.500 (38.1)	1.500 (38.1)
03	1.312 - 18		1.000 (25.4)	1.937 (49.2)	1.937 (49.2)
04	1.500 - 18		1.250 (31.8)	2.187 (55.5)	2.187 (55.5)
05	2.000 - 18		1.625 (41.3)	2.625 (66.7)	2.625 (66.7)

**TABLE II**

Symbol	Finish Description
XB	No Plating - Black Color (Non-Conductive Finish)
XM	2000 Hour Corrosion Resistant Electroless Nickel
XMT	2000 Hour Corrosion Resistant Ni-PTFE, Nickel-Fluorocarbon Polymer. 1000 Hour Grey™
XO	No Plating - Brown Color (Non-Conductive Finish)
XW	2000 Hour Corrosion Resistant Cadmium/Olive Drab over Electroless Nickel

