

1. Mechanical Dimensions:

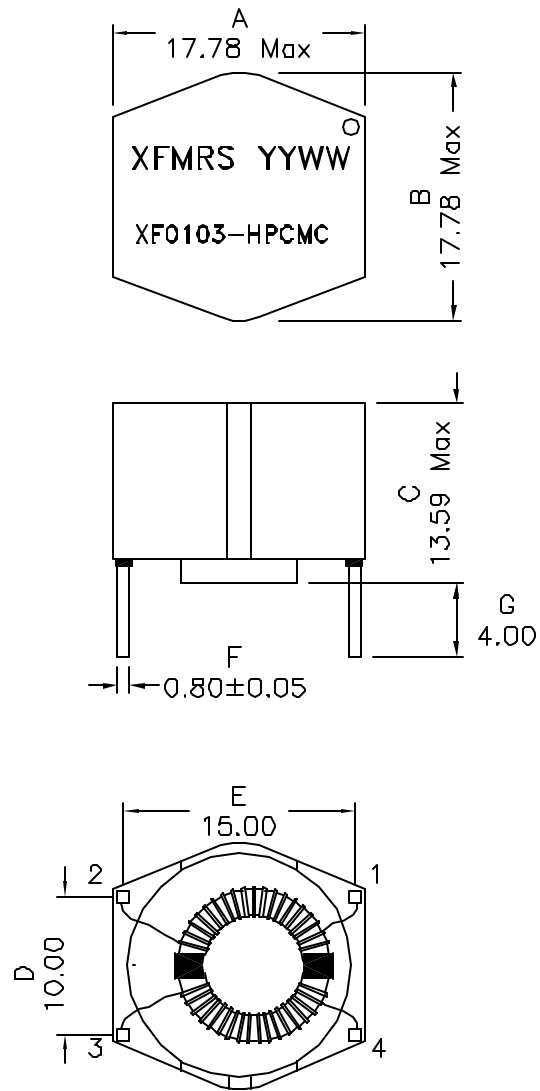

(BOTTOM VIEW)

2. Schematic:

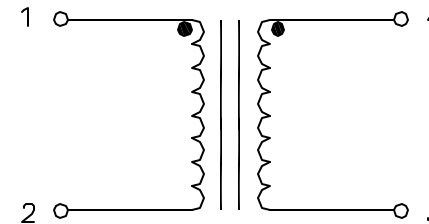

3. Electrical Specifications: @25°C

OCL: 10mH+50/-30% @100KHz 0.1V, Each Wdg
 DCR.: 0.360 Ohms Typ, Each Wdg
 LL: 90uH Typ @100KHz 0.1V
 Rated Current: 0.7Amps
 Isolation Voltage: 1500Vac, Wdg to Wdg
 Rated Voltage: 250VAC

Notes:

1. Solderability: Leads shall meet MIL-STD-202G, Method 208H for solderability.
2. Flammability: UL94V-0
3. ASTM oxygen index: > 28%
4. Insulation System: Class F 155°C. UL file E151556
5. Operating Temperature Range: All listed parameters are to be within tolerance from -40°C to +85°C
6. Storage Temperature Range: -55°C to +125°C
7. Aqueous wash compatible
8. Electrical and mechanical specifications 100% tested
9. RoHS Compliant Component

DOC REV: A/5

PROPRIETARY

Document is the property of XFMRS Group & is not allowed to be duplicated without authorization.

XFMRS Inc.	Title: Common Mode Choke		
	P/N: XF0103-HPCMC		REV. A
UNLESS OTHERWISE SPECIFIED TOLERANCES: .xx ±0.25	DWN.	罗振江	Dec-15-08
Dimensions in MM	CHK.	廖玉坤	Dec-15-08
SHEET 1 OF 1	APP.	BW	Dec-15-08