

M28840/5 Metal Conduit Backshell

Glenair Connector
Designator G

MIL-C-28840

M28840/5 16 W A

Basic Part No. _____

Dash No. _____

Material and Finish _____

W = Aluminum, Cadmium Plate,
Olive Drab over Electroless Nickel
D = CRES 316, Cadmium Plate, Black

Style Designator:

A = EMI/Non-Environmental
B = EMI/Environmental

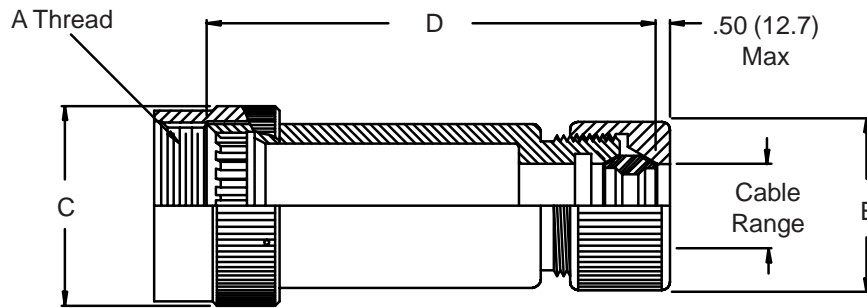

**STYLE A - EMI/Non-Environmental
(Plain Conduit)**

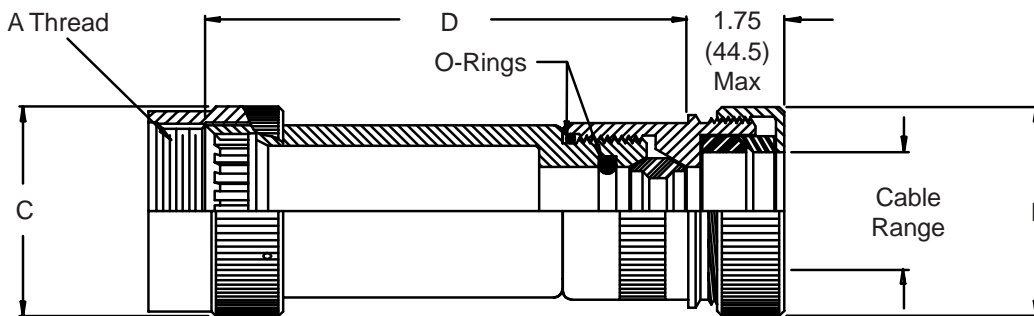

**STYLE B - EMI/Environmental
(Jacket Conduit)**

M28840/5 Metal Conduit Backshell



Conduit &
Accessories

TABLE I

Shell Size	A Thread Class 2B	C Dia Max
A (11)	.750 - 20 UNEF	1.028 (26.1)
B (13)	.875 - 20 UNEF	1.141 (29.0)
C (15)	1.000 - 20 UNEF	1.263 (32.1)
D (17)	1.125 - 18 UNEF	1.387 (35.2)
E (19)	1.250 - 18 UNEF	1.513 (38.4)
F (23)	1.438 - 18 UNEF	1.703 (43.3)
G (25)	1.562 - 18 UNEF	1.825 (46.4)
H (29)	1.875 - 16 UN	2.143 (54.4)
J (33)	2.062 - 16 UNS	2.329 (59.2)

TABLE II

Dash No.	Shell Size Desig.	D Dia		E Max Dia		F Max Dia		Cable Range			
		±.12	(3.1)	Dia		Dia		Min	Max		
01	A (11)	1.75	(44.5)	1.12	(28.4)	1.19	(30.2)	.50	(12.7)	.63	(16.0)
02	B (13)	1.75	(44.5)	1.12	(28.4)	1.19	(30.2)	.50	(12.7)	.63	(16.0)
03	B (13)	1.75	(44.5)	1.25	(31.8)	1.38	(35.1)	.63	(16.0)	.75	(19.1)
04	C (15)	1.75	(44.5)	1.12	(28.4)	1.19	(30.2)	.50	(12.7)	.63	(16.0)
05	C (15)	1.75	(44.5)	1.25	(31.8)	1.38	(35.1)	.63	(16.0)	.75	(19.1)
06	C (15)	1.75	(44.5)	1.43	(36.3)	1.63	(41.4)	.75	(19.1)	.88	(22.4)
07	C (15)	3.00	(76.2)	1.62	(41.1)	1.94	(49.3)	.88	(22.4)	1.00	(25.4)
08	D (17)	2.25	(57.2)	1.43	(36.3)	1.63	(41.4)	.75	(19.1)	.88	(22.4)
09	D (17)	2.25	(57.2)	1.62	(41.1)	1.94	(49.3)	.88	(22.4)	1.00	(25.4)
10	D (17)	2.25	(57.2)	1.81	(46.0)	2.19	(55.6)	1.19	(30.2)	1.38	(35.1)
11	E (19)	2.25	(57.2)	1.43	(36.3)	1.63	(41.4)	.75	(19.1)	.88	(22.4)
12	E (19)	2.25	(57.2)	1.62	(41.1)	1.94	(49.3)	.88	(22.4)	1.00	(25.4)
13	E (19)	2.25	(57.2)	1.81	(46.0)	2.19	(55.6)	1.19	(30.2)	1.38	(35.1)
14	F (23)	2.75	(69.9)	1.62	(41.1)	1.94	(49.3)	.88	(22.4)	1.00	(25.4)
15	F (23)	2.75	(69.9)	1.81	(46.0)	2.19	(55.6)	1.19	(30.2)	1.38	(35.1)
16	F (23)	3.50	(88.9)	2.18	(55.4)	2.44	(62.0)	1.44	(36.6)	1.63	(41.4)
17	G (25)	2.75	(69.9)	1.62	(41.1)	1.94	(49.3)	.88	(22.4)	1.00	(25.4)
18	G (25)	2.75	(69.9)	1.81	(46.0)	2.19	(55.6)	1.19	(30.2)	1.38	(35.1)
19	G (25)	2.75	(69.9)	2.18	(55.4)	2.44	(62.0)	1.44	(36.6)	1.63	(41.4)
20	G (25)	4.00	(101.6)	2.56	(65.0)	2.69	(68.3)	1.63	(41.4)	1.88	(47.8)
21	H (29)	3.25	(82.6)	2.18	(55.4)	2.44	(62.0)	1.44	(36.6)	1.63	(41.4)
22	H (29)	3.25	(82.6)	2.55	(64.8)	2.69	(68.3)	1.63	(41.4)	1.88	(47.8)
23	J (33)	3.25	(82.6)	2.56	(65.0)	2.69	(68.3)	1.63	(41.4)	1.88	(47.8)
24	J (33)	3.25	(82.6)	3.06	(77.7)	3.19	(81.0)	2.13	(54.1)	2.38	(60.5)
25	A (11)	1.75	(44.5)	1.25	(31.8)	1.38	(35.1)	.63	(16.0)	.75	(19.1)

1. Metric dimensions (mm) are indicated in parentheses.
2. For complete dimensions see applicable Military Specification.