

Customer Name	Standard specification	FUJITSU MEDIA DEVICES LIMITED	
Application	IF Filter for Terrestrial-TV		
System	Japan		
Picture Carrier Frequency	57.00 MHz	DATE	Apr. 26 2006
FMD Part Number	FAR-F4SE-57M000-H0J9	Version	2.0

Table 1 Proposal Specification (Ta=25°C(45°C))

Items	Conditions	Specification			Unit	Remarks
		Min.	Typ.	Max.		
Insertion Loss	57.08 (57.00) MHz	10.7	12.2	13.7	dB	
Relative level	45.08 ~ 50.08 MHz (45.00 ~ 50.00 MHz)	–	- 50	- 42	dB	
	50.08 ~ 52.83 MHz (50.00 ~ 52.75 MHz)	–	- 45	- 38	dB	
	52.83 (52.75) MHz	–	- 55	- 40	dB	
	54.18 (54.10) MHz	- 3.8	- 2.6	- 1.4	dB	
	57.08 (57.00) MHz	–	0	–	dB	Reference
	59.58 (59.50) MHz	- 4.3	- 3.1	- 1.9	dB	
	60.33 (60.25) MHz	–	- 44	- 33	dB	
	62.46 (62.38) MHz	–	- 51	- 41	dB	
	64.83 (64.75) MHz	–	- 53	- 43	dB	
	62.46 ~ 70.08 MHz (62.38 ~ 70.00 MHz)	–	- 45	- 38	dB	
Amplitude ripple (p-p)	54.58 ~ 59.08 MHz (54.50 ~ 59.00 MHz)	–	0.4	–	dB	
Group delay ripple (p-p)	54.18 ~ 59.58 MHz (54.10 ~ 59.50 MHz)	–	31	–	ns	
Input Impedance	57.08 MHz	–	1.0//12.7	–	kΩ//pF	
Output Impedance	57.08 MHz	–	1.2//3.5	–	kΩ//pF	
Temperature coefficient		–	-72	–	ppm/°C	

Customer Name	Standard specification	FUJITSU MEDIA DEVICES LIMITED	
Application	IF Filter for Terrestrial-TV		
System	Japan		
Picture Carrier Frequency	57.00 MHz	DATE	Apr. 26 2006
FMD Part Number	FAR-F4SE-57M000-H0J9	Version	2.0

1. Pin assignment of plastics Package

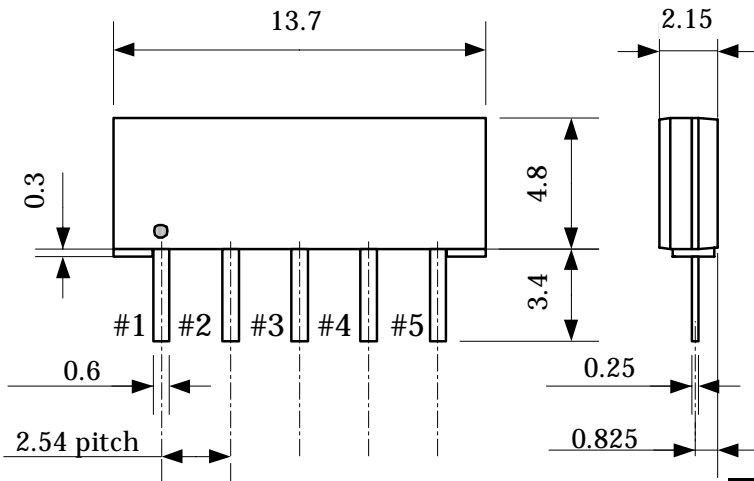

Pin No.	Pin name	Description
1	IN	input pin
2	IN	input pin (Ground)
3	GND	Ground pin
4	OUT	output pin
5	OUT	output pin

2. Measurement circuit

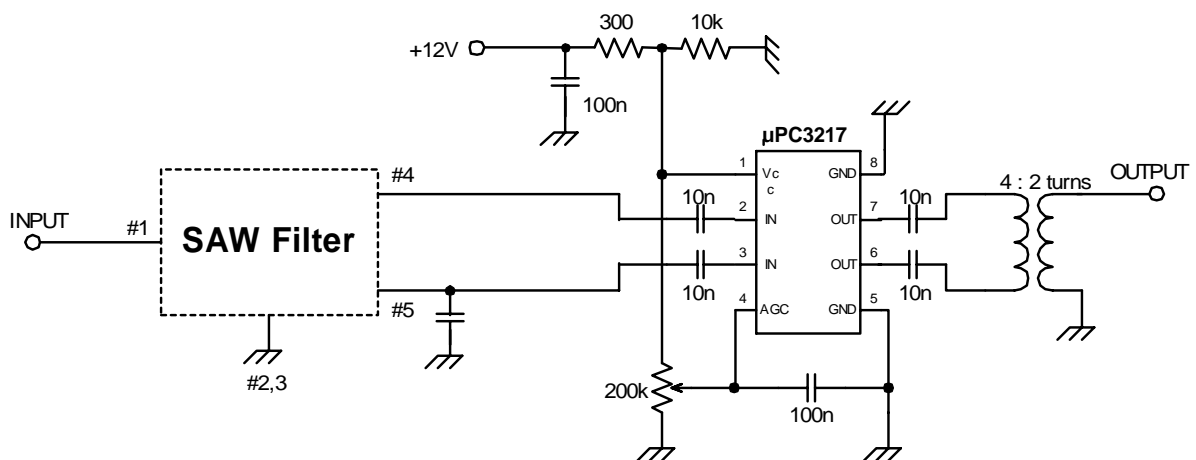

Customer Name	Standard specification	FUJITSU MEDIA DEVICES LIMITED	
Application	IF Filter for Terrestrial-TV		
System	Japan		
Picture Carrier Frequency	57.00 MHz	DATE	Apr. 26 2006
FMD Part Number	FAR-F4SE-57M000-H0J9	Version	2.0

Amplitude Response (10dB/div)

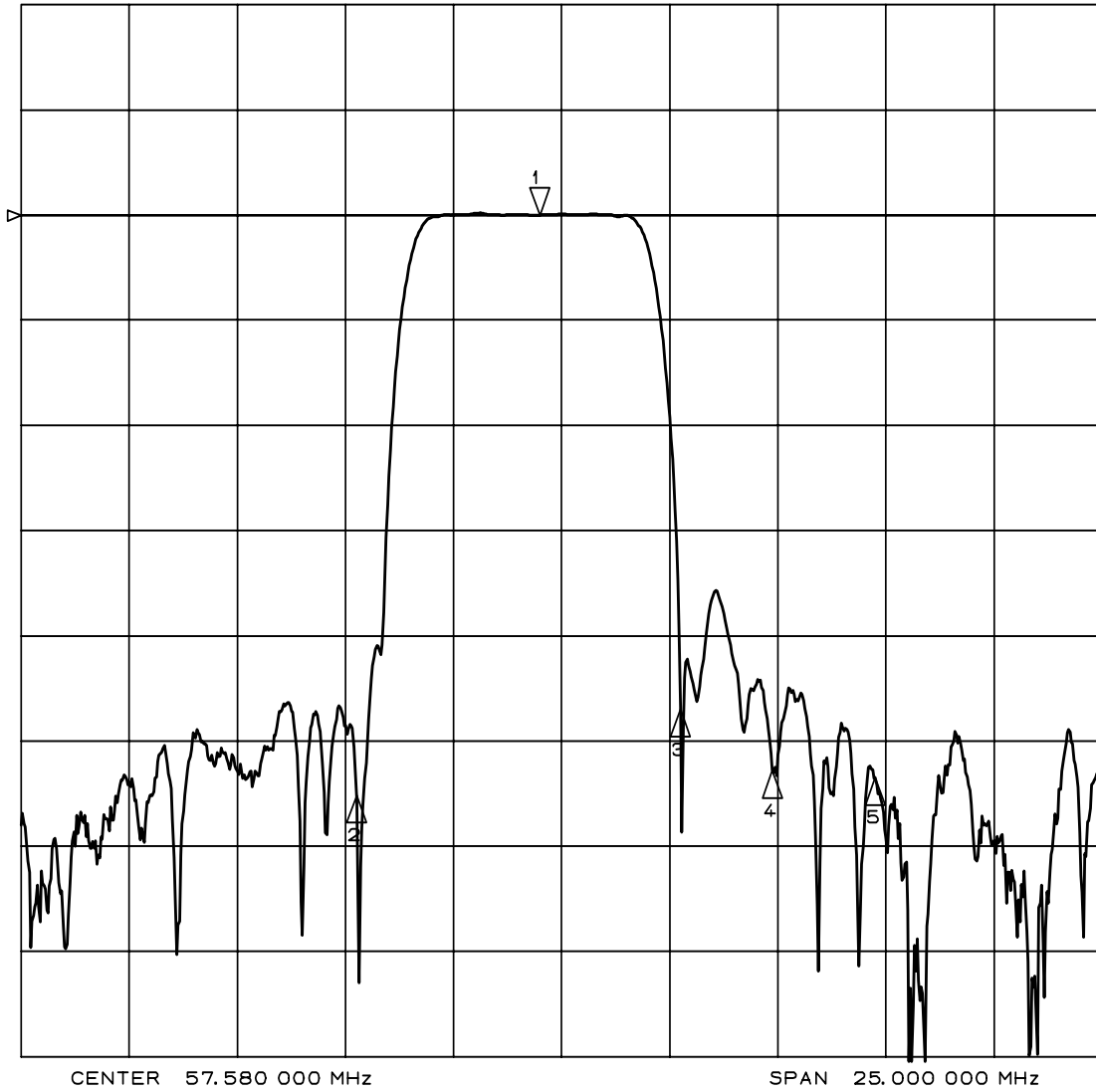

- Marker 1 = 57.08 MHz
- Marker 2 = 52.83 MHz
- Marker 3 = 60.33 MHz
- Marker 4 = 62.46 MHz
- Marker 5 = 64.83 MHz

Customer Name	Standard specification	FUJITSU MEDIA DEVICES LIMITED	
Application	IF Filter for Terrestrial-TV		
System	Japan		
Picture Carrier Frequency	57.00 MHz	DATE	Apr. 26 2006
FMD Part Number	FAR-F4SE-57M000-H0J9	Version	2.0

Amplitude Response (1dB/div)

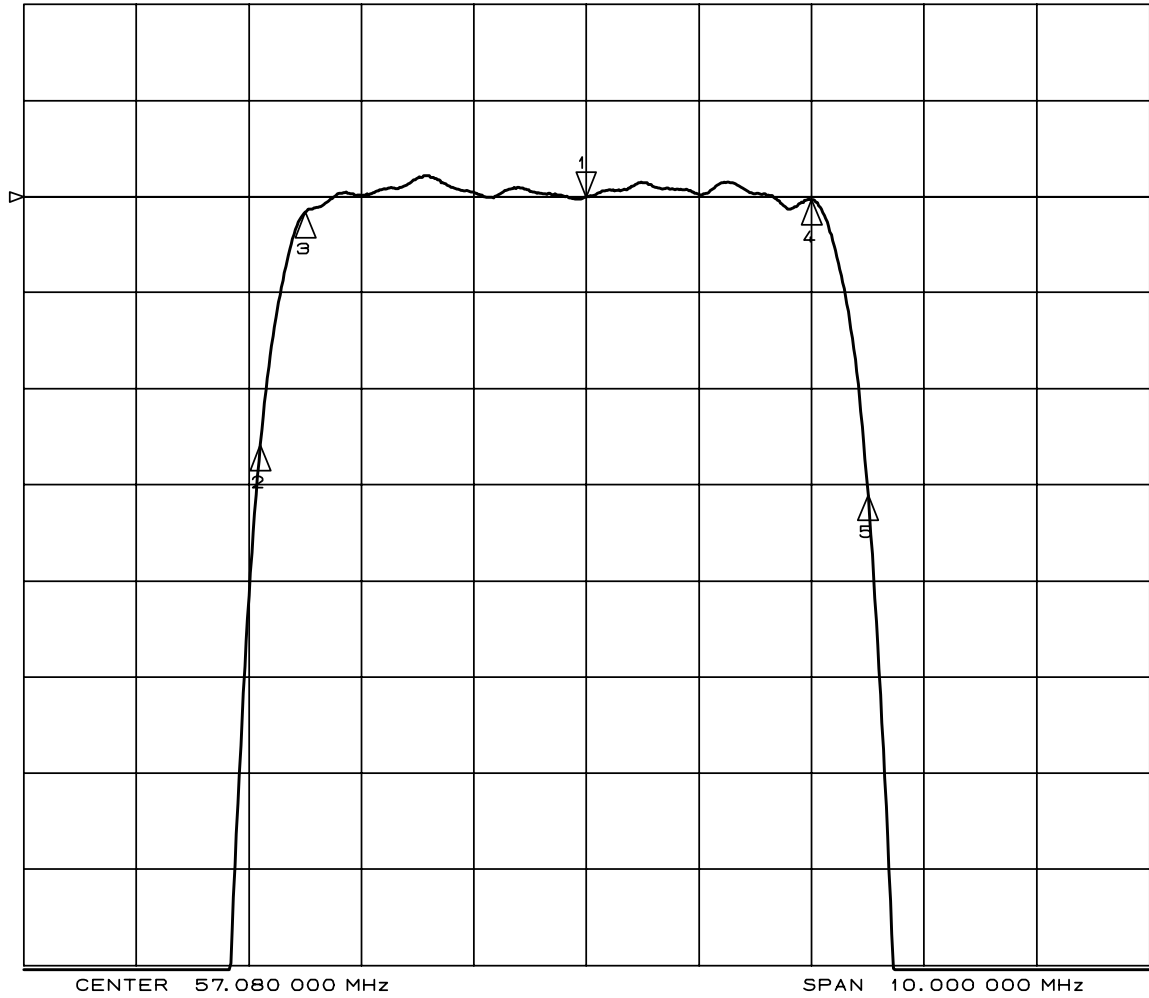

- Marker 1 = 57.08 MHz
- Marker 2 = 54.18 MHz
- Marker 3 = 54.58 MHz
- Marker 4 = 59.08 MHz
- Marker 5 = 59.58 MHz

Customer Name	Standard specification	FUJITSU MEDIA DEVICES LIMITED	
Application	IF Filter for Terrestrial-TV		
System	Japan		
Picture Carrier Frequency	57.00 MHz	DATE	Apr. 26 2006
FMD Part Number	FAR-F4SE-57M000-H0J9	Version	2.0

Group Delay (50ns/div)

Delay Aper.=200kHz

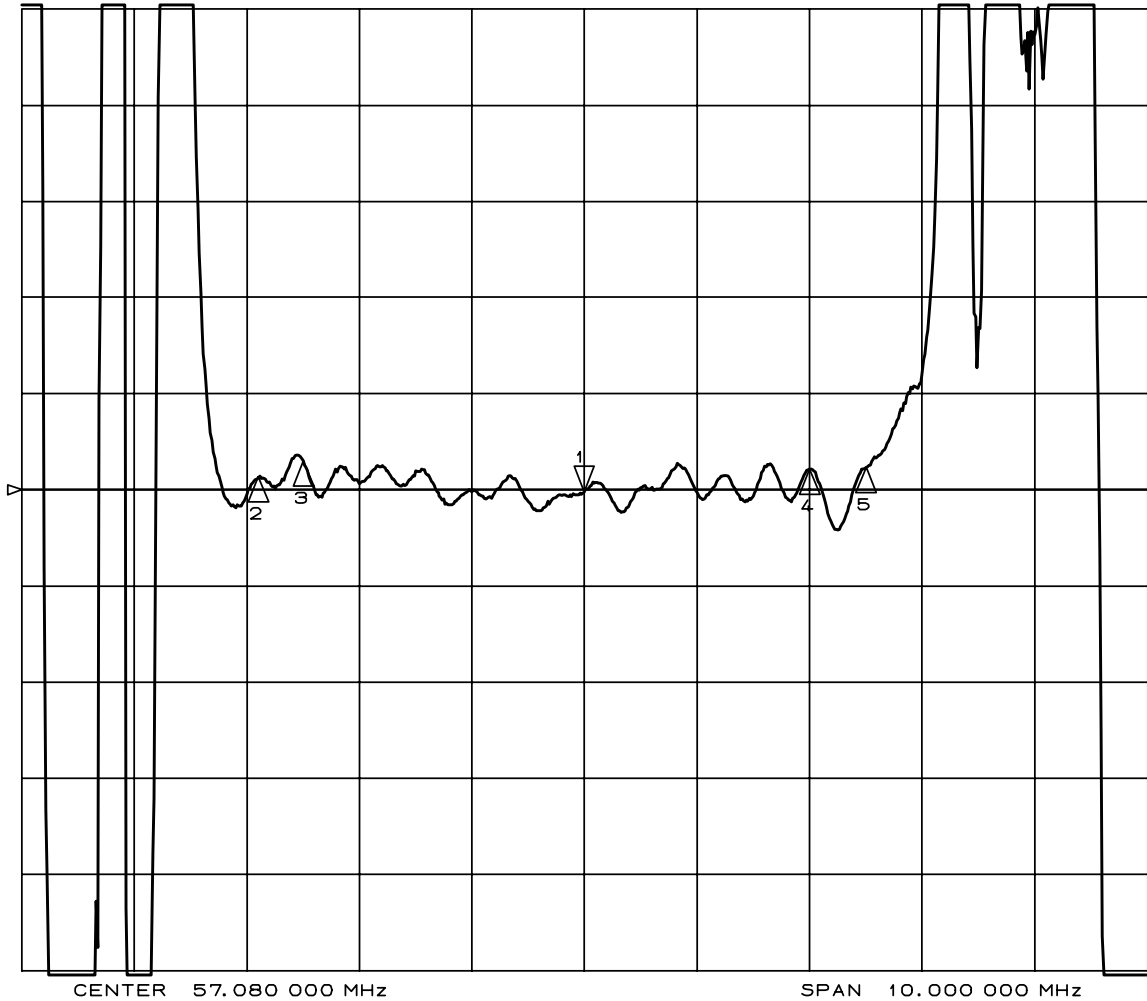

- Marker 1 = 57.08 MHz
- Marker 2 = 54.18 MHz
- Marker 3 = 54.58 MHz
- Marker 4 = 59.08 MHz
- Marker 5 = 59.58 MHz

Customer Name	Standard specification	FUJITSU MEDIA DEVICES LIMITED	
Application	IF Filter for Terrestrial-TV		
System	Japan		
Picture Carrier Frequency	57.00 MHz	DATE	Apr. 26 2006
FMD Part Number	FAR-F4SE-57M000-H0J9	Version	2.0

Amplitude Response (10dB/div)
(30.0MHz ----- 180.0MHz)

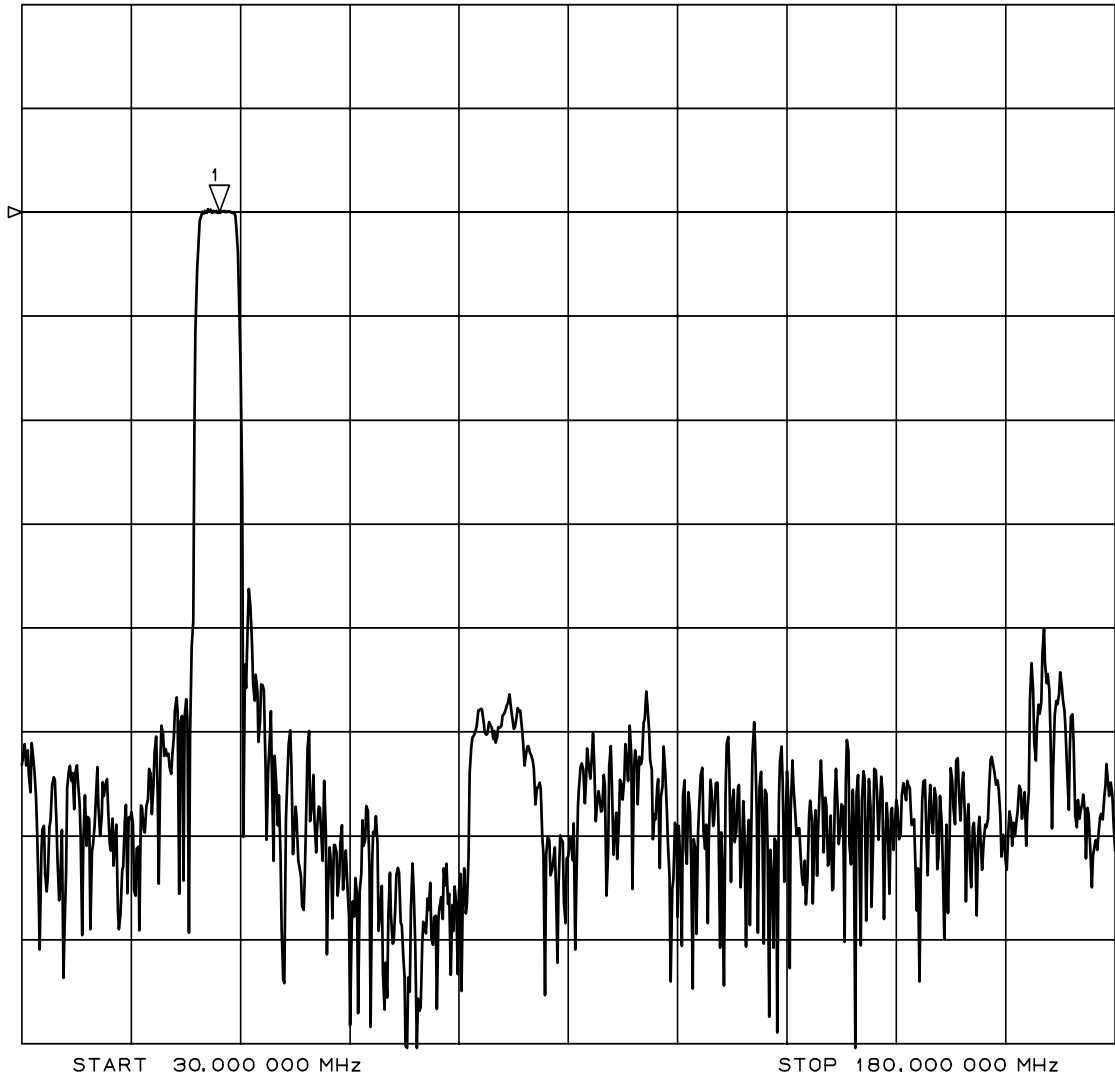

Marker 1 = 57.08 MHz

Customer Name	Standard specification	FUJITSU MEDIA DEVICES LIMITED	
Application	IF Filter for Terrestrial-TV		
System	Japan		
Picture Carrier Frequency	57.00 MHz	DATE	Apr. 26 2006
FMD Part Number	FAR-F4SE-57M000-H0J9	Version	2.0

Time domain Response (10dB/div)

