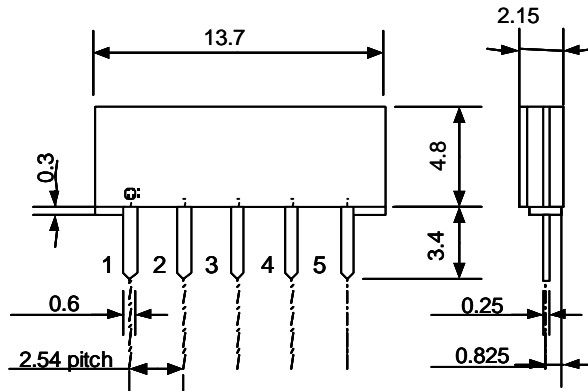


Customer Name	<b>Standard specification</b>	FUJITSU MEDIA DEVICES LIMITED	
System	TV-IF	DATE	Aug.12 2004
FMD Part Number	FAR-F4SE-44M000-H0A3	Version 1.0	

**Table 1. Electrical specifications**

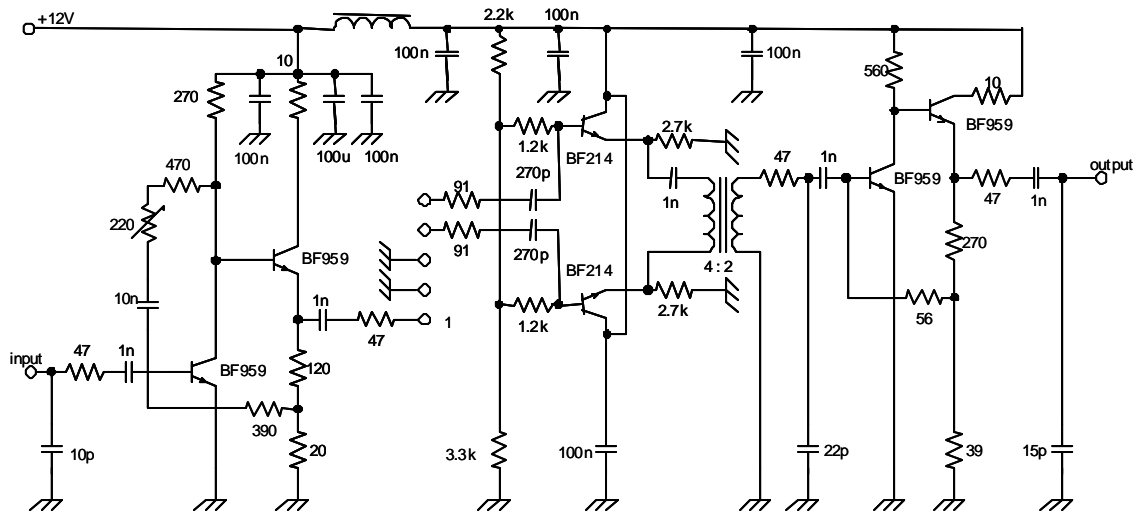
Ta=25 °C (45 °C)							
Item	Condition (MHz)	FMD Proposal			Unit	Remarks	
		Min.	Typ.	Max.			
Insertion Loss	44.060(44.000)	12.5	14.0	15.5	dB		
Band Width	1dB down	-	3.6	-	MHz		
	3dB down	-	4.0	-	MHz		
	30dB down	-	5.5	-	MHz		
Relative Attenuation	40.810(40.750)	-	-43	-36	dB		
	42.060(42.000)	-3.6	-2.4	-1.2	dB		
	42.530(42.470)	-1.1	-0.1	0.9	dB		
	44.060(44.000)	-	0	-	dB	Ref.	
	45.590(45.530)	-1.1	-0.1	0.9	dB		
	46.060(46.000)	-4.7	-3.5	-2.3	dB		
	46.810(46.750)	-	-38	-29	dB		
	Lower sidelobe	35.060 – 39.060 (35.000 – 39.000)	-	-45	-40	dB	
		39.060 – 41.060 (39.000 – 41.000)	-	-39	-35	dB	
	Upper sidelobe	47.060 – 49.060 (47.000 – 49.000)	-	-36	-33	dB	
		49.060 – 55.060 (49.000 – 55.000)	-	-41	-36	dB	
	Amplitude Ripple (p-p)	42.530 – 45.590 (42.470 – 45.530)	-	0.3	0.7	dB	
Group delay Ripple (p-p)	42.530 – 45.590 (42.470 – 45.530)	-	30	70	ns		
Capacitance at 1MHz	Cin	-	13.2	-	pF		
	Cout	-	2.4	-	pF		
Temperature drift	Cf	-	-72	-	ppm/°C		

Customer Name	<b>Standard specification</b>	FUJITSU MEDIA DEVICES LIMITED	
System	TV-IF	DATE	Aug.12 2004
FMD Part Number	FAR-F4SE-44M000-H0A3	Version 1.0	



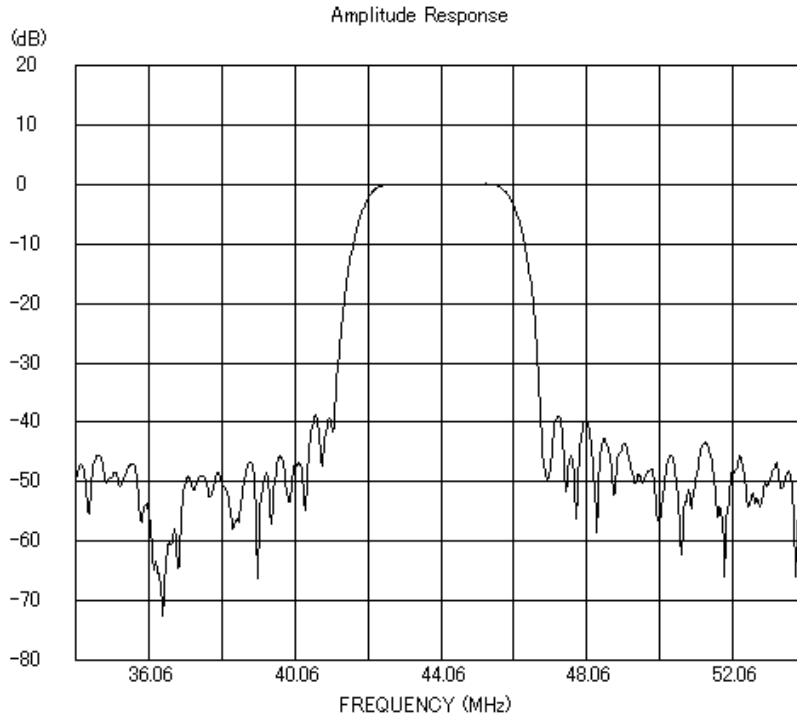
<b>Pin No. 1</b>	<b>INPUT</b>
<b>2</b>	<b>INPUT</b>
<b>3</b>	<b>GROUND</b>
<b>4</b>	<b>OUTPUT</b>
<b>5</b>	<b>OUTPUT</b>

**Figure 1. Package Dimension**

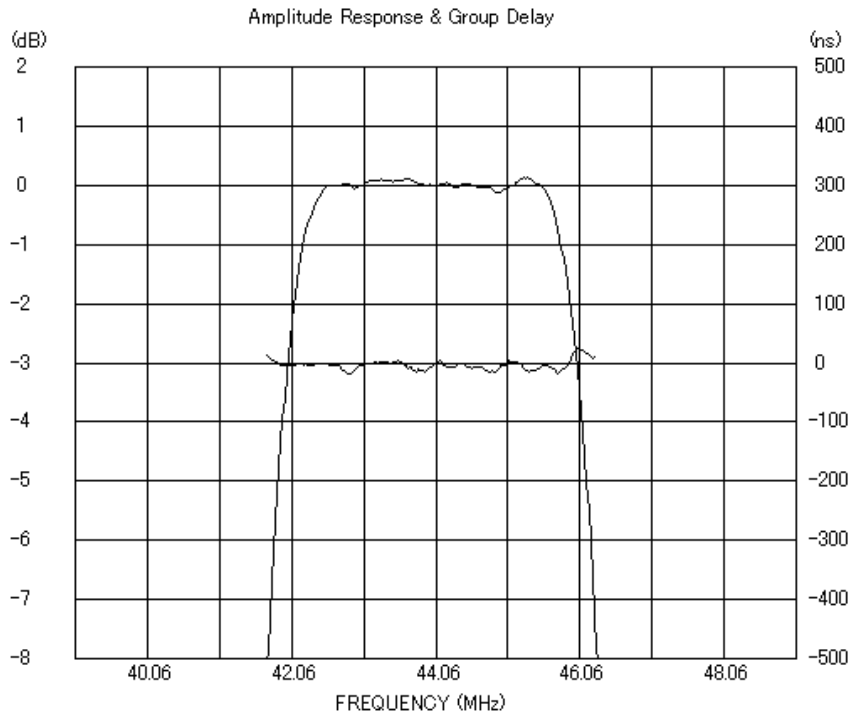


**Figure 2. Measurement Circuit**

Customer Name	<b>Standard specification</b>	FUJITSU MEDIA DEVICES LIMITED	
System	TV-IF	DATE	Aug.12 2004
FMD Part Number	FAR-F4SE-44M000-H0A3	Version 1.0	



**Figure 3. Full-band characteristics**



**Figure 4. Pass-band and group delay characteristics**