

**PLEASE CHECK WWW.MOLEX.COM FOR LATEST PART INFORMATION**

**Part Number:** **0190840003**  
**Status:** **Active**  
**Description:** Open Barrel Star Ring, Brass, for 14-18 AWG Wire, Stud Size 10

**Documents:**

[Drawing \(PDF\)](#) [RoHS Certificate of Compliance \(PDF\)](#)  
[Product Specification PS-19902-006 \(PDF\)](#)

**Agency Certification**

CSA LR18689  
 UL E32244

**General**

Product Family Ring and Spade Terminals  
 Series 19084  
 Crimp Quality Equipment Yes  
 Mil-Spec N/A  
 Product Name N/A  
 Type Ring

**Physical**

Barrel Type Open  
 Insulation None  
 Material - Plating Mating Tin  
 Packaging Type Reel  
 Plating min: Mating (µin) 100  
 Plating min: Mating (µm) 2.5  
 Plating min: Termination (µin) 100  
 Plating min: Termination (µm) 2.5  
 Stud Size 10 (M5)  
 Termination Interface: Style Crimp or Compression  
 Wire Insulation Diameter N/A  
 Wire Size AWG 14, 16, 18  
 Wire Size mm<sup>2</sup> 0.80 - 2.00

**Material Info**

Old Part Number SRZ-0129-10

**Reference - Drawing Numbers**

Product Specification PS-19902-006  
 Sales Drawing SD-19084-001

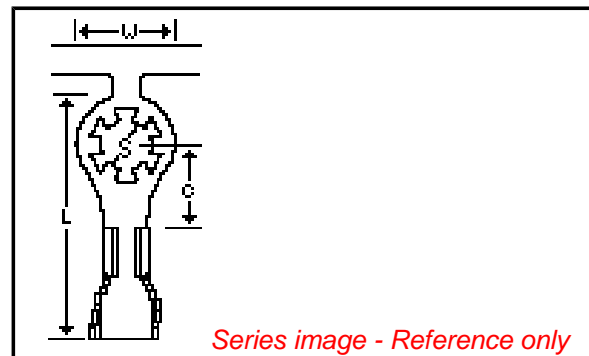

**EU RoHS**

**ELV and RoHS Compliant**  
**REACH SVHC Contains SVHC: No**  
**Halogen-Free Status**  
**Halogen-Free**

**China RoHS**



**Need more information on product environmental compliance?**

Email [productcompliance@molex.com](mailto:productcompliance@molex.com)  
 For a multiple part number RoHS Certificate of Compliance, [click here](#)

Please visit the [Contact Us](#) section for any non-product compliance questions.

**Search Parts in this Series**

[19084Series](#)

**Application Tooling | [FAQ](#)**

*Tooling specifications and manuals are found by selecting the products below. Crimp Height Specifications are then contained in the Application Tooling Specification document.*

**Global**

Description	Product #
ASP Perishable Tool Kit used in ASP presses that process metal strip product	<a href="#">0190290053</a>
Mini-Mac™ Applicator	<a href="#">0638815600</a>

MATERIAL NO.	ENG. NO.	STUD SIZE	"S"±.003	MATERIAL	PLATING
190840001	SRZ-0129-06	6	.146/3.71	BRASS	NONE
190840002	SRZ-0129-08	8	.173/4.39		
190840003	SRZ-0129-10	10	.198/5.03	BRASS	TIN
190840004	SRZ-4129-06	6	.146/3.71		
190840005	SRZ-4129-08	8	.173/4.39		
190840006	SRZ-4129-10	10	.198/5.03	STEEL	
190840007	SRZ-S-4129-06	6	.146/3.71		
190840008	SRZ-S-4129-08	8	.173/4.39		
190840009	SRZ-S-4129-10	10	.198/5.03		

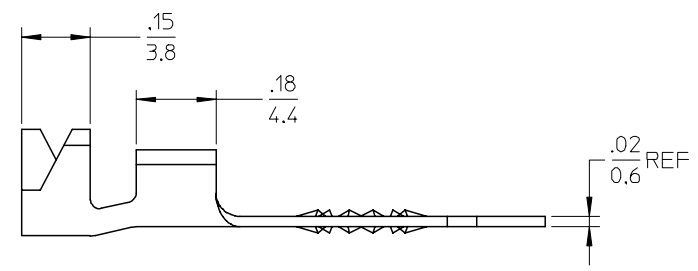
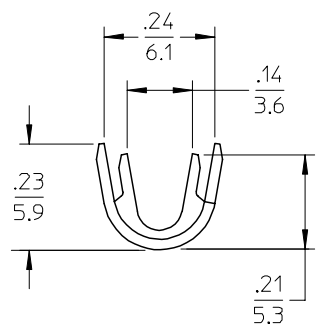
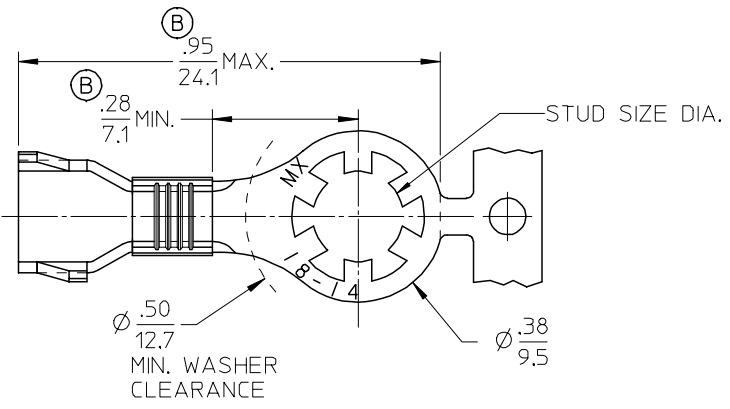

SALES DRAWING

NOTE(S):  
 1. WIRE: SIZE: 18-14 AWG  
 0.7 - 2.6 MM<sup>2</sup>

UPDATE TO MX STDS EC NO: ETC2001-0128 DRWNG: JYR/CK 2005/02/18 CHKD: JPAML/CK 2005/02/18 APPR: JPAML/CK 2005/02/18	DESCRIPTION REV	QUALITY SYMBOLS ▽=0 ▽=0	GENERAL TOLERANCES (UNLESS SPECIFIED)		DIMENSION STYLE	SCALE	DESIGN UNITS	THIRD ANGLE PROJECTION	
					IN/MM		INCH		
			4 PLACES	± ---	± ---	DRAWN BY	DATE		TITLE
			3 PLACES	± ---	± .005	CHECKED BY	DATE		
2 PLACES	± 0.13	± .01	APPROVED BY	DATE					
1 PLACE	± 0.25	± ---							
			ANGULAR ±1/2°						
			DRAFT WHERE APPLICABLE MUST REMAIN WITHIN DIMENSIONS		MATERIAL NO.	DOCUMENT NO.	SHEET NO.		
					SEE CHART	SD-19084-001	1 OF 1		
					THIS DRAWING CONTAINS INFORMATION THAT IS PROPRIETARY TO MOLEX INCORPORATED AND SHOULD NOT BE USED WITHOUT WRITTEN PERMISSION				

OPEN BARREL STRIP  
 STAR RING, VIBRAKRIMP  
 18-14 AWG



MOLEX INCORPORATED