



**SANYO Semiconductors**

# DATA SHEET

# LC871HC4A LC871H92A

CMOS IC

128K/96K-byte ROM and 12288-byte RAM integrated

## 8-bit 1-chip Microcontroller with USB-host controller

### Overview

The LC871HC4A/92A is an 8-bit microcomputer that, centered around a CPU running at a minimum bus cycle time of 83.3ns, integrates on a single chip a number of hardware features such as 128K/96K-byte ROM, 12288-byte RAM, a sophisticated 16-bit timer/counter (may be divided into 8-bit timers), a 16-bit timer (may be divided into 8-bit timers or PWMs), four 8-bit timers with a prescaler, a base timer serving as a time-of-day clock, 3 channels of synchronous SIO interface with automatic data transfer capabilities, an asynchronous/synchronous SIO interface, a UART interface (full duplex), a full-speed USB interface (host control function), an 8-bit 12-channel AD converter, 2 channels of 12-bit PWM, a system clock frequency divider, an infrared remote control receiver circuit, and a 40-source 10-vector interrupt feature.

### Features

#### ■ROM

- 131072 × 8 bits (LC871HC4A)
- 98304 × 8 bits (LC871H92A)

#### ■RAM

- 12288 × 9 bits

#### ■Bus Cycle Time

- 83.3ns (When CF=12MHz)

Note: The bus cycle time here refers to the ROM read speed.

#### ■Minimum Instruction Cycle Time (tCYC)

- 250ns (When CF=12MHz)

■ Any and all SANYO Semiconductor Co.,Ltd. products described or contained herein are, with regard to "standard application", intended for the use as general electronics equipment (home appliances, AV equipment, communication device, office equipment, industrial equipment etc.). The products mentioned herein shall not be intended for use for any "special application" (medical equipment whose purpose is to sustain life, aerospace instrument, nuclear control device, burning appliances, transportation machine, traffic signal system, safety equipment etc.) that shall require extremely high level of reliability and can directly threaten human lives in case of failure or malfunction of the product or may cause harm to human bodies, nor shall they grant any guarantee thereof. If you should intend to use our products for applications outside the standard applications of our customer who is considering such use and/or outside the scope of our intended standard applications, please consult with us prior to the intended use. If there is no consultation or inquiry before the intended use, our customer shall be solely responsible for the use.

■ Specifications of any and all SANYO Semiconductor Co.,Ltd. products described or contained herein stipulate the performance, characteristics, and functions of the described products in the independent state, and are not guarantees of the performance, characteristics, and functions of the described products as mounted in the customer's products or equipment. To verify symptoms and states that cannot be evaluated in an independent device, the customer should always evaluate and test devices mounted in the customer's products or equipment.

**SANYO Semiconductor Co., Ltd.**

TOKYO OFFICE Tokyo Bldg., 1-10, 1 Chome, Ueno, Taito-ku, TOKYO, 110-8534 JAPAN

# LC871HC4A/92A

## ■ Ports

- I/O ports
  - Ports whose I/O direction can be designated in 1-bit units 28 (P10 to P17, P20 to P27, P30 to P34, P70 to P73, PWM0, PWM1, XT2)
  - Ports whose I/O direction can be designated in 4-bit units 8 (P00 to P07)
- USB ports 2 (UHD+, UHD-)
- Dedicated oscillator ports 2 (CF1, CF2)
- Input-only port (also used for oscillation) 1 (XT1)
- Reset pins 1 (RES)
- Power supply pins 6 (V<sub>SS</sub>1 to 3, V<sub>DD</sub>1 to 3)

## ■ Timers

- Timer 0: 16-bit timer/counter with 2 capture registers.
  - Mode 0: 8-bit timer with an 8-bit programmable prescaler (with two 8-bit capture registers) × 2 channels
  - Mode 1: 8-bit timer with an 8-bit programmable prescaler (with two 8-bit capture registers) + 8-bit counter (with two 8-bit capture registers)
  - Mode 2: 16-bit timer with an 8-bit programmable prescaler (with two 16-bit capture registers)
  - Mode 3: 16-bit counter (with two 16-bit capture registers)
- Timer 1: 16-bit timer/counter that supports PWM/toggle outputs
  - Mode 0: 8-bit timer with an 8-bit prescaler (with toggle outputs) + 8-bit timer/counter with an 8-bit prescaler (with toggle outputs)
  - Mode 1: 8-bit PWM with an 8-bit prescaler × 2 channels
  - Mode 2: 16-bit timer/counter with an 8-bit prescaler (with toggle outputs) (toggle outputs also possible from lower-order 8 bits)
  - Mode 3: 16-bit timer with an 8-bit prescaler (with toggle outputs) (lower-order 8 bits may be used as a PWM output)
- Timer 4: 8-bit timer with a 6-bit prescaler
- Timer 5: 8-bit timer with a 6-bit prescaler
- Timer 6: 8-bit timer with a 6-bit prescaler (with toggle outputs)
- Timer 7: 8-bit timer with a 6-bit prescaler (with toggle outputs)
- Base timer
  - 1) The clock is selectable from the subclock (32.768kHz crystal oscillation), system clock, and timer 0 prescaler output.
  - 2) Interrupts programmable in 5 different time schemes

## ■ SIO

- SIO0: Synchronous serial interface
  - 1) LSB first/MSB first mode selectable
  - 2) Transfer clock cycle: 4/3 to 512/3 tCYC
  - 3) Automatic continuous data transmission (1 to 256 bits, specifiable in 1-bit units) (Suspension and resumption of data transmission possible in 1 byte units)
- SIO1: 8-bit asynchronous/synchronous serial interface
  - Mode 0: Synchronous 8-bit serial I/O (2- or 3-wire configuration, 2 to 512 tCYC transfer clocks)
  - Mode 1: Asynchronous serial I/O (half-duplex, 8 data bits, 1 stop bit, 8 to 2048 tCYC baudrates)
  - Mode 2: Bus mode 1 (start bit, 8 data bits, 2 to 512 tCYC transfer clocks)
  - Mode 3: Bus mode 2 (start detect, 8 data bits, stop detect)
- SIO4: Synchronous serial interface
  - 1) LSB first/MSB first mode selectable
  - 2) Transfer clock cycle: 4/3 to 1020/3 tCYC
  - 3) Automatic continuous data transmission (1 to 4096 bytes, specifiable in 1 byte units) (Suspension and resumption of data transmission possible in 1 byte units or in word units)
  - 4) Auto-start-on-falling-edge function
  - 5) Clock polarity selectable
  - 6) CRC16 calculator circuit built in

Continued on next page.

Continued from preceding page.

- SIO9: Synchronous serial interface
  - 1) LSB first/MSB first mode selectable
  - 2) Transfer clock cycle: 4/3 to 1020/3 tCYC
  - 3) Automatic continuous data transmission (1 to 4096 bytes, specifiable in 1 byte units)  
(Suspension and resumption of data transmission possible in 1 byte units or word units)
  - 4) Auto-start-on-falling-edge function
  - 5) Clock polarity selectable
  - 6) CRC16 calculator circuit built in

■ Full Duplex UART

- 1) Data length: 7/8/9 bits selectable
- 2) Stop bits: 1 bit (2 bits in continuous transmission mode)
- 3) Baud rate: 16/3 to 8192/3 tCYC

■ AD Converter: 8 bits × 12 channels

■ PWM: Multifrequency 12-bit PWM × 2 channels

■ Infrared Remote Control Receiver Circuit

- 1) Noise rejection function (noise filter time constant: Approx. 120μs when the 32.768kHz crystal oscillator is selected as the base clock)
- 2) Supports data encoding systems such as PPM (Pulse Position Modulation) and Manchester encoding.
- 3) X'tal HOLD mode reset function

■ USB Interface (host control function)

- 1) Compliant with full-speed (12M bps) specifications
- 2) Supports 4 transfer types (control transfer, bulk transfer, interrupt transfer, and isochronous transfer).

■ Audio Interface

- 1) Sampling frequency (fs): 32kHz, 44.1kHz, 48kHz
- 2) Master clock frequency (internal PLL): 12.288MHz, 16.9344MHz, 18.432MHz
- 3) Bit clock selectable: 48fs/64fs
- 4) Data bit length: 16/18/20/24 bits
- 5) LSB first/MSB firsts selectable
- 6) Left-justification/right-justification selectable

■ Watchdog Timer

- Watchdog timer using external RC circuitry
- Interrupt and reset signals selectable

■ Clock Output Function

- 1) Can output a clock with a clock rate of 1/1, 1/2, 1/4, 1/8, 1/16, 1/32, or 1/64 of the source oscillator clock selected as the system clock.
- 2) Can output the source oscillation clock for the subclock.

## ■ Interrupts

- 40 sources, 10 vector addresses
  - 1) Provides three levels (low (L), high (H), and highest (X)) of multiplex interrupt control. Any interrupt requests of the level equal to or lower than the current interrupt are not accepted.
  - 2) When interrupt requests to two or more vector addresses occur at the same time, the interrupt of the highest level takes precedence over the other interrupts. For interrupts of the same level, the interrupt into the smallest vector address takes precedence.

No.	Vector Address	Level	Interrupt Source
1	00003H	X or L	INT0
2	0000BH	X or L	INT1
3	00013H	H or L	INT2/T0L/INT4/UHC bus active/remote control signal receive
4	0001BH	H or L	INT3/INT5/base timer
5	00023H	H or L	T0H/INT6/UHC device connected/UHC disconnected/UHC resume
6	0002BH	H or L	T1L/T1H/INT7/SIO9/AIF start
7	00033H	H or L	SIO0/UART1 receive
8	0003BH	H or L	SIO1/SIO4/UART1 transmit/end of AIF
9	00043H	H or L	ADC/T6/T7/UHC-ACK/UHC-NAK/UHC error/UHC STALL
10	0004BH	H or L	Port 0/PWM0/PWM1/T4/T5/UHC-SOF/DMCOPY

- Priority levels  $X > H > L$
- Of interrupts of the same level, the one with the smallest vector address takes precedence.

## ■ Subroutine Stack Levels: 6144 levels maximum (The stack is allocated in RAM.)

## ■ High-speed Multiplication/Division Instructions

- 16 bits  $\times$  8 bits (5 tCYC execution time)
- 24 bits  $\times$  16 bits (12 tCYC execution time)
- 16 bits  $\div$  8 bits (8 tCYC execution time)
- 24 bits  $\div$  16 bits (12 tCYC execution time)

## ■ Oscillation and PLL Circuits

- RC oscillation circuit (internal): For system clock
- CF oscillation circuit: For system clock
- Crystal oscillation circuit: For system clock, time-of-day clock
- PLL circuit (internal): For USB interface (see Fig.5)), audio interface (see Fig. 6)

## ■ Standby Function

- HALT mode: Halts instruction execution while allowing the peripheral circuits to continue operation.
  - 1) Oscillation is not halted automatically.
  - 2) There are three ways of resetting the HALT mode.
    - (1) Setting the reset pin to the lower level.
    - (2) Reset generated by watchdog timer
    - (3) Interrupt generation
- HOLD mode: Suspends instruction execution and the operation of the peripheral circuits.
  - 1) The PLL base clock generator, CF, RC and crystal oscillators automatically stop operation.
  - 2) There are five ways of resetting the HOLD mode.
    - (1) Setting the reset pin to the lower level.
    - (2) Reset generated by watchdog timer
    - (3) Setting at least one of the INT0, INT1, INT2, INT4, and INT5 pins to the specified level
    - (4) Having an interrupt source established at port 0
    - (5) Having an bus active interrupt source established in the USB host controll circuit

Continued on next page.

## LC871HC4A/92A

Continued from preceding page.

- X'tal HOLD mode: Suspends instruction execution and the operation of the peripheral circuits except the base timer.
  - 1) The PLL base clock generator, CF and RC oscillator automatically stop operation.
  - 2) The state of crystal oscillation established when the X'tal HOLD mode is entered is retained.
  - 3) There are seven ways of resetting the X'tal HOLD mode.
    - (1) Setting the reset pin to the low level
    - (2) Reset generated by watchdog timer
    - (3) Setting at least one of the INT0, INT1, INT2, INT4, and INT5 pins to the specified level
    - (4) Having an interrupt source established at port 0
    - (5) Having an interrupt source established in the base timer circuit
    - (6) Having an bus active interrupt source established in the USB host controll circuit
    - (7) Having an interrupt source established in the infrared remote controller receiver circuit

### ■ Package Form

- SQFP48(7×7): Lead-free type

### ■ Development Tools

- On-chip debugger: TCB87- type-B + LC87F1HC4A

## Package Dimensions

unit : mm (typ)

3163B

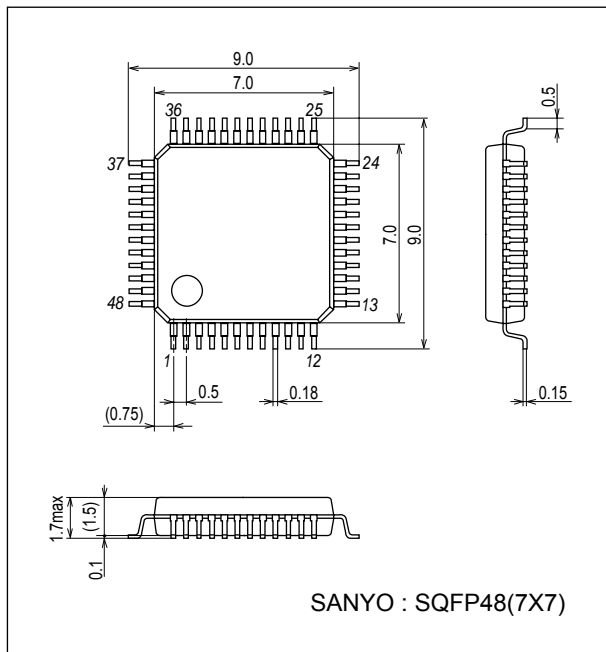

# LC871HC4A/92A

## Pin Assignment

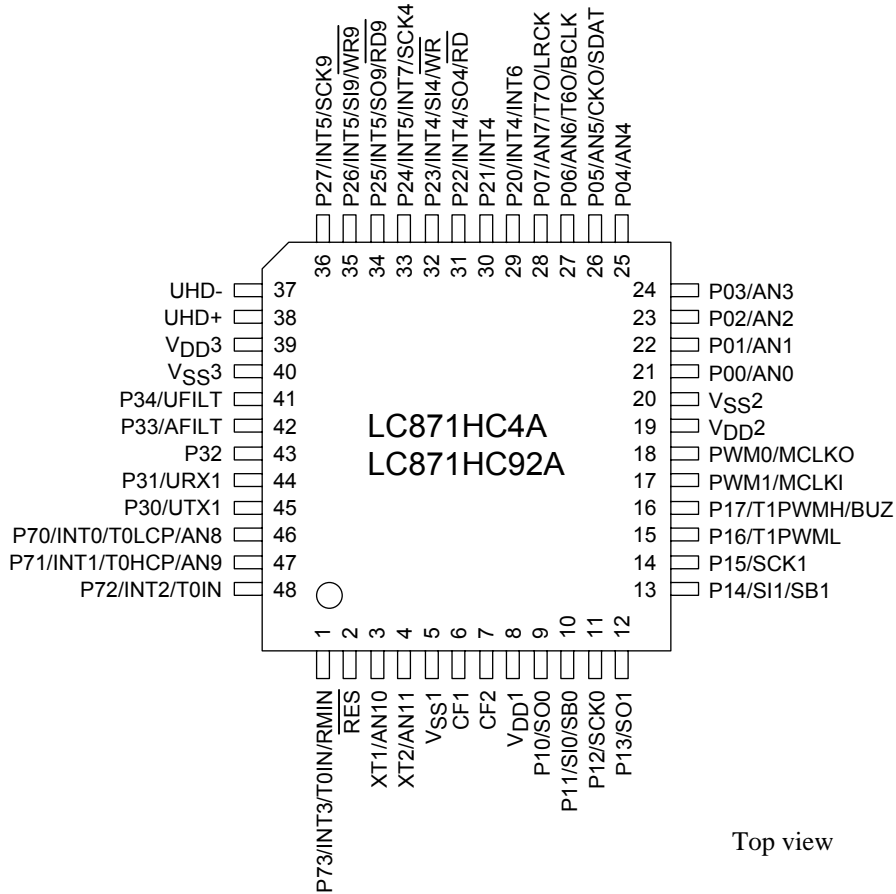

SANYO : SQFP48(7×7) “Lead-free Type”

SQFP48	NAME
1	P73/INT3/T0IN/RMIN
2	RES
3	XT1/AN10
4	XT2/AN11
5	VSS1
6	CF1
7	CF2
8	VDD1
9	P10/SO0
10	P11/SI0/SB0
11	P12/SCK0
12	P13/SO1
13	P14/SI1/SB1
14	P15/SCK1
15	P16/T1PWML
16	P17/T1PWMH/BUZ
17	PWM1/MCLKI
18	PWM0/MCLKO
19	VDD2
20	VSS2
21	P00/AN0
22	P01/AN1
23	P02/AN2
24	P03/AN3

SQFP48	NAME
25	P04/AN4
26	P05/AN5/CKO/SDAT
27	P06/AN6/T6O/BCLK
28	P07/AN7/T7O/LRCK
29	P20/INT4/INT6
30	P21/INT4
31	P22/INT4/SO4/RD
32	P23/INT4/SI4/WR
33	P24/INT5/INT7/SCK4
34	P25/INT5/SO9/RD9
35	P26/INT5/SI9/WR9
36	P27/INT5/SCK9
37	UHD-
38	UHD+
39	VDD3
40	VSS3
41	P34/UFILT
42	P33/AFILT
43	P32
44	P31/URX1
45	P30/UTX1
46	P70/INT0/T0LCP/AN8
47	P71/INT1/T0HCP/AN9
48	P72/INT2/T0IN

System Block Diagram

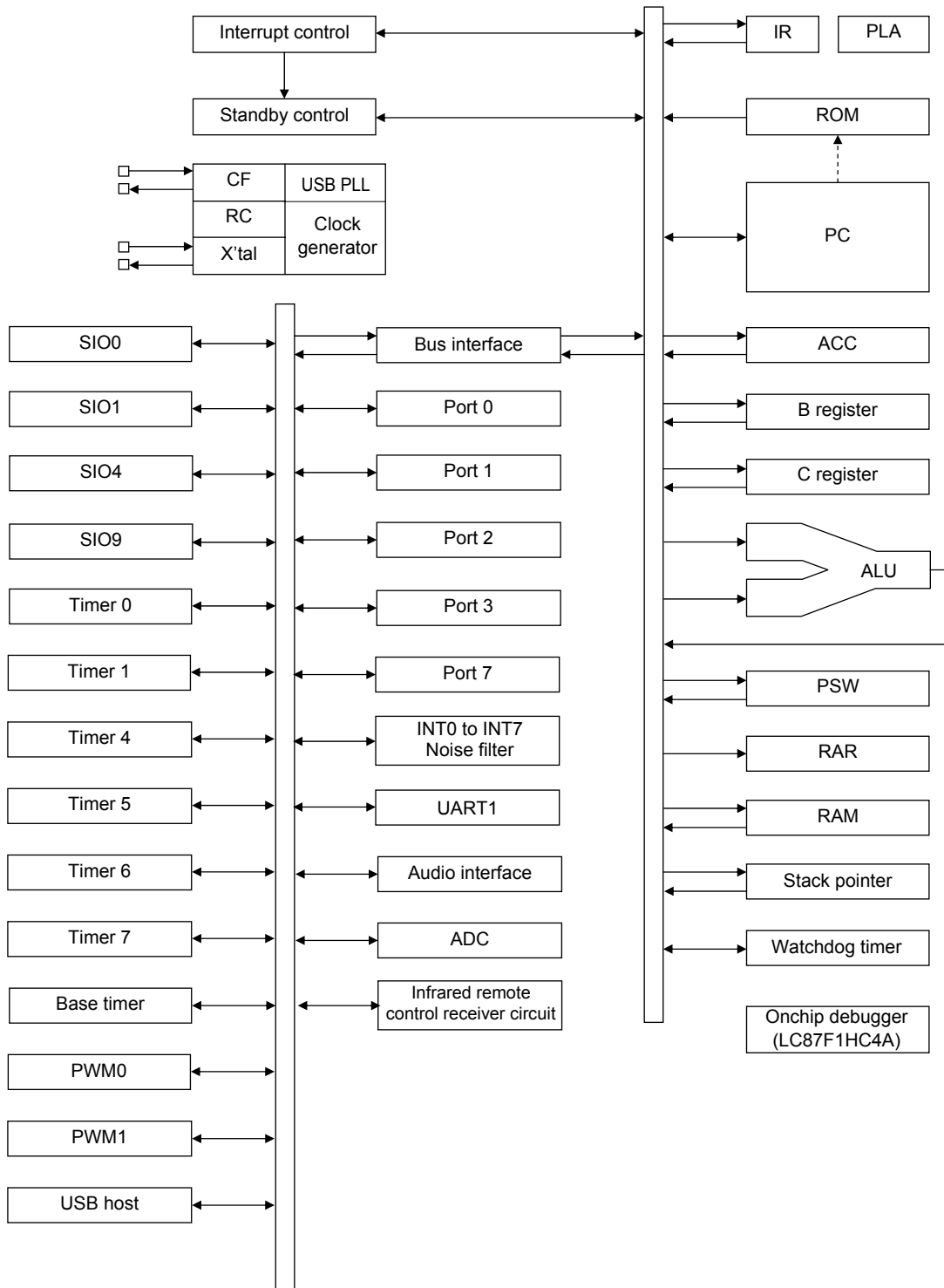





# LC871HC4A/92A

Continued from preceding page.

Pin Name	I/O	Description	Option																														
Port 7 P70 to P73	I/O	<ul style="list-style-type: none"> <li>• 4-bit I/O port</li> <li>• I/O specifiable in 1-bit units</li> <li>• Pull-up resistors can be turned on and off in 1-bit units.</li> <li>• Pin functions</li> </ul> P70: INT0 input/HOLD reset input/timer 0L capture input/watchdog timer output P71: INT1 input/HOLD reset input/timer 0H capture input P72: INT2 input/HOLD reset input/timer 0 event input/timer 0L capture input/ high speed clock counter input P73: INT3 input (input with noise filter)/timer 0 event input/timer 0H capture input/ IR remote controller receiver input AD converter input ports: AN8(P70), AN9(P71) Interrupt acknowledge types <table border="1" style="width: 100%; border-collapse: collapse; margin-top: 5px;"> <thead> <tr> <th></th> <th>Rising</th> <th>Falling</th> <th>Rising &amp; Falling</th> <th>H level</th> <th>L level</th> </tr> </thead> <tbody> <tr> <td>INT0</td> <td>enable</td> <td>enable</td> <td>disable</td> <td>enable</td> <td>enable</td> </tr> <tr> <td>INT1</td> <td>enable</td> <td>enable</td> <td>disable</td> <td>enable</td> <td>enable</td> </tr> <tr> <td>INT2</td> <td>enable</td> <td>enable</td> <td>enable</td> <td>disable</td> <td>disable</td> </tr> <tr> <td>INT3</td> <td>enable</td> <td>enable</td> <td>enable</td> <td>disable</td> <td>disable</td> </tr> </tbody> </table>		Rising	Falling	Rising & Falling	H level	L level	INT0	enable	enable	disable	enable	enable	INT1	enable	enable	disable	enable	enable	INT2	enable	enable	enable	disable	disable	INT3	enable	enable	enable	disable	disable	No
	Rising	Falling	Rising & Falling	H level	L level																												
INT0	enable	enable	disable	enable	enable																												
INT1	enable	enable	disable	enable	enable																												
INT2	enable	enable	enable	disable	disable																												
INT3	enable	enable	enable	disable	disable																												
PWM0 PWM1	I/O	PWM0, PWM1 output port General-purpose input port <ul style="list-style-type: none"> <li>• Pin functions</li> </ul> PWM0: Audio interface master clock output PWM1: Audio interface master clock input	No																														
UHD-	I/O	USB data I/O pin UHD-/general-purpose I/O port	No																														
UHD+	I/O	USB data I/O pin UHD+/general-purpose I/O port	No																														
RES	Input	Reset pin	No																														
XT1	Input	<ul style="list-style-type: none"> <li>• 32.768kHz crystal oscillator input</li> <li>• Pin functions</li> </ul> General-purpose input port AD converter input ports: AN10 Must be connected to $V_{DD1}$ when not to be used.	No																														
XT2	I/O	<ul style="list-style-type: none"> <li>• 32.768kHz crystal oscillator output</li> <li>• Pin functions</li> </ul> General-purpose I/O AD converter input port: AN11 Must be set for oscillation and kept open if not to be used.	No																														
CF1	Input	Ceramic/crystal resonator input	No																														
CF2	Output	Ceramic/crystal resonator output	No																														

## LC871HC4A/92A

### Port Output Types

The table below lists the types of port outputs and the presence/absence of a pull-up resistor.  
Data can be read into any input port even if it is in the output mode.

Port Name	Option selected in units of	Option type	Output type	Pull-up resistor
P00 to P07	each bit	1	CMOS	Programmable (Note 1)
		2	Nch-open drain	No
P10 to P17 P20 to P27 P30 to P34	each bit	1	CMOS	Programmable
		2	Nch-open drain	Programmable
P70	-	No	Nch-open drain	Programmable
P71 to P73	-	No	CMOS	Programmable
PWM0, PWM1	-	No	CMOS	No
UHD+, UHD-	-	No	CMOS	No
XT1	-	No	Input only	No
XT2	-	No	32.768kHz crystal resonator output (N channel open drain when in general-purpose output mode)	No

Note 1: Programmable pull-up resistors for port 0 are controlled in 4 bit units (P00 to 03, P04 to 07).

### User Option List

Option Name	Option Type	Mask Version *1	Flash Version	Option Selected in Units of	Specified item
Port output form	P00 to P07	○	○	each bit	CMOS
					Nch-open drain
	P10 to P17	○	○	each bit	CMOS
					Nch-open drain
	P20 to P27	○	○	each bit	CMOS
					Nch-open drain
	P30 to P34	○	○	each bit	CMOS
					Nch-open drain
Program start address	-	× *2	○	-	00000h
					1FE00h
USB Regulator	USB Regulator	○	○	-	USE
					NONUSE
	USB Regulator (at HOLD mode)	○	○	-	USE
					NONUSE
	USB Regulator (at HALT mode)	○	○	-	USE
					NONUSE

\*1: Mask option selection - No change possible after the mask is completed.

\*2: Program start address of the mask version is 00000h.

# LC871HC4A/92A

## Power Pin Treatment

Connect the IC as shown below to minimize the noise input to the  $V_{DD1}$  pin, and extend the backup period. Be sure to electrically short the  $V_{SS1}$ ,  $V_{SS2}$ , and  $V_{SS3}$  pins.

Example 1: When the microcontroller is in the backup state in the HOLD mode, the power to sustain the high level of output ports is supplied by their backup capacitors.

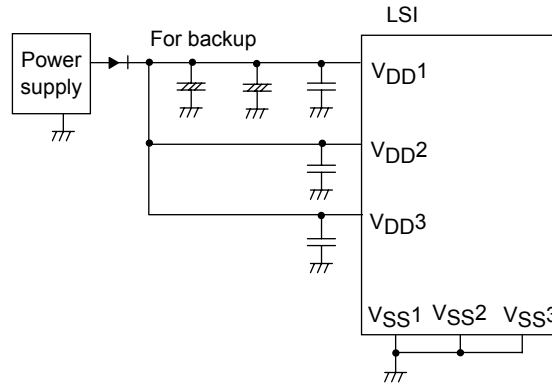

Example 2: The high level output at ports is not sustained and unstable in the HOLD backup mode.

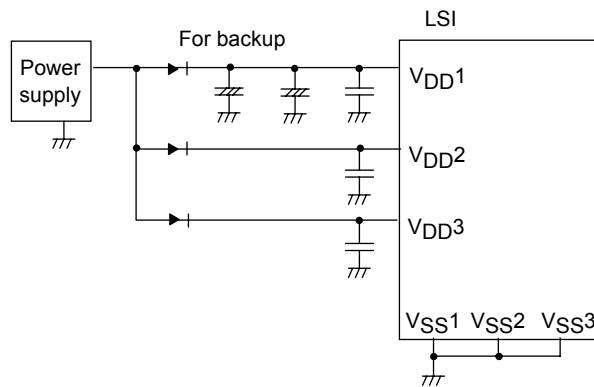

**USB Reference Power Option**

When a voltage 4.5 to 5.5V is supplied to V<sub>DD1</sub> and the internal USB reference voltage circuit is activated, the reference voltage for USB port output is generated. The active/inactive state of the reference voltage circuit can be switched by option select. The procedure for marking the option selection is described below.

		(1)	(2)	(3)	(4)
Option settings	USB regulator	USE	USE	USE	NONUSE
	USB regulator at HOLD mode	USE	NONUSE	NONUSE	NONUSE
	USB regulator at HALT mode	USE	NONUSE	USE	NONUSE
Reference voltage circuit state	Normal mode	active	active	active	inactive
	HOLD mode	active	inactive	inactive	inactive
	HALT mode	active	inactive	active	inactive

- When the USB reference voltage circuit is made inactive, the level of the reference voltage for USB port output is equal to V<sub>DD1</sub>.
- Selection (2) or (3) can be used to set the reference voltage circuit inactive in HOLD or HALT mode.
- When the reference voltage circuit is activated, the current drain increases by approximately 100μA compared with when the reference voltage circuit is inactive.

Example 1: V<sub>DD1</sub>=V<sub>DD2</sub>=3.3V

- Inactivating the reference voltage circuit (selection (4)).
- Connecting V<sub>DD3</sub> to V<sub>DD1</sub> and V<sub>DD2</sub>.

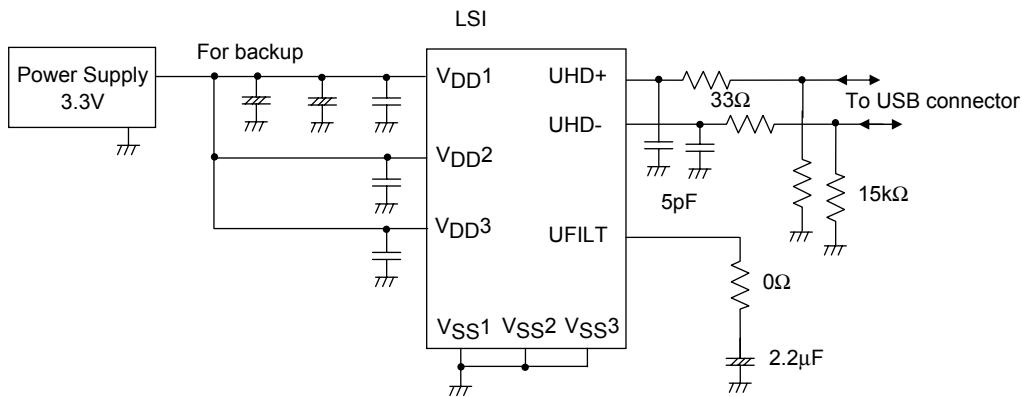

Example 2: V<sub>DD1</sub>=V<sub>DD2</sub>=5.0V

- Activating the reference voltage circuit (selection (1)).
- Isolating V<sub>DD3</sub> from V<sub>DD1</sub> and V<sub>DD2</sub>, and connecting capacitor between V<sub>DD3</sub> and V<sub>SS</sub>.

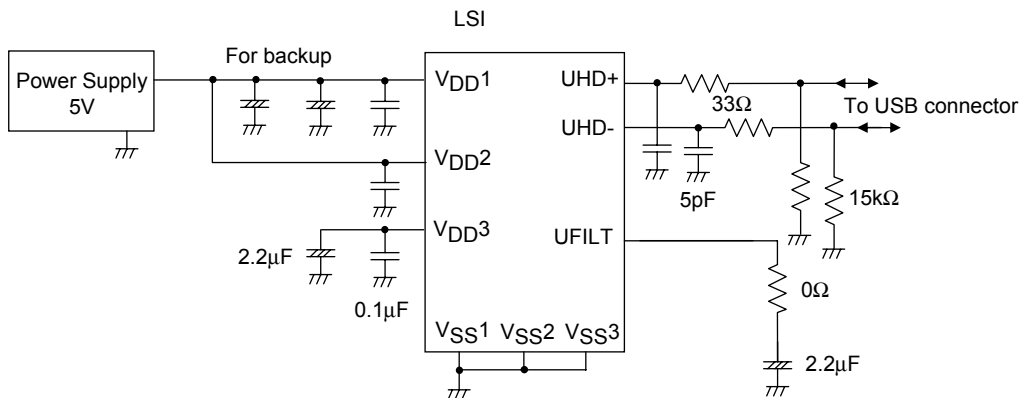

# LC871HC4A/92A

## Absolute Maximum Ratings at Ta = 25°C, VSS1 = VSS2 = VSS3 = 0V

Parameter	Symbol	Pin/Remarks	Conditions	Specification				unit
				VDD[M]	min	typ	max	
Maximum supply voltage	VDD max	VDD1, VDD2, VDD3	VDD1=VDD2=VDD3		-0.3		+6.5	V
Input voltage	VI(1)	XT1, CF1			-0.3		VDD+0.3	
Input/output voltage	VI(1)	Ports 0, 1, 2, 3, 7 PWM0, PWM1 XT2			-0.3		VDD+0.3	
High level output current	Peak output current	IOPH(1)	Ports 0, 1, 2	• When CMOS output type is selected • Per 1 applicable pin		-10		mA
		IOPH(2)	PWM0, PWM1	Per 1 applicable pin		-20		
		IOPH(3)	Port 3 P71 to P73	• When CMOS output type is selected • Per 1 applicable pin		-5		
	Average output current (Note 1-1)	IOMH(1)	Ports 0, 1, 2	• When CMOS output type is selected • Per 1 applicable pin		-7.5		
		IOMH(2)	PWM0, PWM1	Per 1 applicable pin		-15		
		IOMH(3)	Port 3 P71 to P73	• When CMOS output type is selected • Per 1 applicable pin		-3		
	Total output current	ΣIOAH(1)	Ports 0, 2	Total current of all applicable pins		-25		
		ΣIOAH(2)	Port 1 PWM0, PWM1	Total current of all applicable pins		-25		
		ΣIOAH(3)	Ports 0, 1, 2 PWM0, PWM1	Total current of all applicable pins		-45		
		ΣIOAH(4)	Port 3 P71 to P73	Total current of all applicable pins		-10		
ΣIOAH(5)		UHD+, UHD-	Total current of all applicable pins		-25			
Low level output current	Peak output current	IOPL(1)	P02 to P07 Ports 1, 2 PWM0, PWM1	Per 1 applicable pin			20	
		IOPL(2)	P00, P01	Per 1 applicable pin			30	
		IOPL(3)	Ports 3, 7 XT2	Per 1 applicable pin			10	
	Average output current (Note 1-1)	IOML(1)	P02 to P07 Ports 1, 2 PWM0, PWM1	Per 1 applicable pin			15	
		IOML(2)	P00, P01	Per 1 applicable pin			20	
		IOML(3)	Ports 3, 7 XT2	Per 1 applicable pin			7.5	
	Total output current	ΣIOAL(1)	Ports 0, 2	Total current of all applicable pins			45	
		ΣIOAL(2)	Port 1 PWM0, PWM1	Total current of all applicable pins			45	
		ΣIOAL(3)	Ports 0, 1, 2 PWM0, PWM1	Total current of all applicable pins			80	
		ΣIOAL(4)	Ports 3, 7 XT2	Total current of all applicable pins			15	
ΣIOAL(5)		UHD+, UHD-	Total current of all applicable pins			25		
Allowable power Dissipation	Pd max	SQFP48(7×7)	Ta=-40 to +85°C				140	mW
Operating ambient Temperature	Topr				-40		+85	°C
Storage ambient temperature	Tstg				-55		+125	

Note 1-1: The average output current is an average of current values measured over 100ms intervals.

# LC871HC4A/92A

## Allowable Operating Conditions at Ta = -40°C to +85°C, V<sub>SS1</sub> = V<sub>SS2</sub> = V<sub>SS3</sub> = 0V

Parameter	Symbol	Pin/Remarks	Conditions	Specification				unit
				V <sub>DD</sub> [V]	min	typ	max	
Operating supply voltage	V <sub>DD</sub> (1)	V <sub>DD1</sub> =V <sub>DD2</sub> =V <sub>DD3</sub>	0.245μs ≤ tCYC ≤ 200μs		3.0		5.5	V
			0.490μs ≤ tCYC ≤ 200μs		2.7		5.5	
Memory sustaining supply voltage	V <sub>H</sub> D	V <sub>DD1</sub> =V <sub>DD2</sub> =V <sub>DD3</sub>	RAM and register contents sustained in HOLD mode.		2.0		5.5	
High level input voltage	V <sub>I</sub> H(1)	Ports 0, 1, 2, 3 P71 to P73 P70 port input/ interrupt side PWM0, PWM1		2.7 to 5.5	0.3V <sub>DD</sub> +0.7		V <sub>DD</sub>	
	V <sub>I</sub> H(2)	Port 70 watchdog timer side		2.7 to 5.5	0.9V <sub>DD</sub>		V <sub>DD</sub>	
	V <sub>I</sub> H(3)	XT1, XT2, CF1, $\overline{\text{RES}}$		2.7 to 5.5	0.75V <sub>DD</sub>		V <sub>DD</sub>	
Low level input voltage	V <sub>I</sub> L(1)	Ports 1, 2, 3 P71 to P73		4.0 to 5.5	V <sub>SS</sub>		0.1V <sub>DD</sub> +0.4	
	V <sub>I</sub> L(2)	P70 port input/ interrupt side		2.7 to 4.0	V <sub>SS</sub>		0.2V <sub>DD</sub>	
	V <sub>I</sub> L(3)	Port 0 PWM0, PWM1		4.0 to 5.5	V <sub>SS</sub>		0.15V <sub>DD</sub> +0.4	
	V <sub>I</sub> L(4)			2.7 to 4.0	V <sub>SS</sub>		0.2V <sub>DD</sub>	
	V <sub>I</sub> L(5)	Port 70 watchdog timer side		2.7 to 5.5	V <sub>SS</sub>		0.8V <sub>DD</sub> -1.0	
	V <sub>I</sub> L(6)	XT1, XT2, CF1, $\overline{\text{RES}}$		2.7 to 5.5	V <sub>SS</sub>		0.25V <sub>DD</sub>	
Instruction cycle time (Note 2-1)	tCYC			3.0 to 5.5	0.245		200	μs
				2.7 to 5.5	0.490		200	
External system clock frequency	FEXCF(1)	CF1	<ul style="list-style-type: none"> <li>• CF2 pin open</li> <li>• System clock frequency division ratio=1/1</li> <li>• External system clock duty =50±5%</li> </ul>	3.0 to 5.5	0.1		12	MHz
			<ul style="list-style-type: none"> <li>• CF2 pin open</li> <li>• System clock frequency division ratio=1/1</li> <li>• External system clock duty =50±5%</li> </ul>	2.7 to 5.5	0.1		6	
Oscillation frequency range (Note 2-2)	FmCF(1)	CF1, CF2	When 12MHz ceramic oscillation See Fig. 1.	3.0 to 5.5		12		MHz
	FmCF(2)	CF1, CF2	When 6MHz ceramic oscillation See Fig. 1.	2.7 to 5.5		6		
	FmRC		Internal RC oscillation	2.7 to 5.5	0.3	1.0	2.0	
	FsX'tal	XT1, XT2	32.768kHz crystal oscillation See Fig. 2.	2.7 to 5.5		32.768		kHz

Note 2-1: Relationship between tCYC and oscillation frequency is 3/FmCF at a division ratio of 1/1 and 6/FmCF at a division ratio of 1/2.

Note 2-2: See Tables 1 and 2 for the oscillation constants.

# LC871HC4A/92A

## Electrical Characteristics at Ta = -40°C to +85°C, VSS1 = VSS2 = VSS3 = 0V

Parameter	Symbol	Pin/Remarks	Conditions	Specification				
				VDD[V]	min	typ	max	unit
High level input current	I <sub>IH</sub> (1)	Ports 0, 1, 2, 3 Port 7 $\overline{\text{RES}}$ PWM0, PWM1 UHD+, UHD-	Output disabled Pull-up resistor off V <sub>IN</sub> =V <sub>DD</sub> (Including output Tr's off leakage current)	2.7 to 5.5			1	μA
	I <sub>IH</sub> (2)	XT1, XT2	Input port configuration V <sub>IN</sub> =V <sub>DD</sub>	2.7 to 5.5			1	
	I <sub>IH</sub> (3)	CF1	V <sub>IN</sub> =V <sub>DD</sub>	2.7 to 5.5			15	
Low level input current	I <sub>IL</sub> (1)	Ports 0, 1, 2, 3 Port 7 $\overline{\text{RES}}$ PWM0, PWM1 UHD+, UHD-	Output disabled Pull-up resistor off V <sub>IN</sub> =V <sub>SS</sub> (Including output Tr's off leakage current)	2.7 to 5.5	-1			μA
	I <sub>IL</sub> (2)	XT1, XT2	Input port configuration V <sub>IN</sub> =V <sub>SS</sub>	2.7 to 5.5	-1			
	I <sub>IL</sub> (3)	CF1	V <sub>IN</sub> =V <sub>SS</sub>	2.7 to 5.5	-15			
High level output voltage	V <sub>OH</sub> (1)	Ports 0, 1, 2, 3 P71 to P73	I <sub>OH</sub> =-1mA	4.5 to 5.5	V <sub>DD</sub> -1			V
	V <sub>OH</sub> (2)		I <sub>OH</sub> =-0.4mA	3.0 to 5.5	V <sub>DD</sub> -0.4			
	V <sub>OH</sub> (3)		I <sub>OH</sub> =-0.2mA	2.7 to 5.5	V <sub>DD</sub> -0.4			
	V <sub>OH</sub> (4)	PWM0, WM1 P05 to P07 (Note 3-1)	I <sub>OH</sub> =-10mA	4.5 to 5.5	V <sub>DD</sub> -1.5			
	V <sub>OH</sub> (5)		I <sub>OH</sub> =-1.6mA	3.0 to 5.5	V <sub>DD</sub> -0.4			
	V <sub>OH</sub> (6)		I <sub>OH</sub> =-1mA	2.7 to 5.5	V <sub>DD</sub> -0.4			
Low level output voltage	V <sub>OL</sub> (1)	P00, P01	I <sub>OL</sub> =30mA	4.5 to 5.5			1.5	V
	V <sub>OL</sub> (2)		I <sub>OL</sub> =5mA	3.0 to 5.5			0.4	
	V <sub>OL</sub> (3)		I <sub>OL</sub> =2.5mA	2.7 to 5.5			0.4	
	V <sub>OL</sub> (4)	Ports 0, 1, 2 PWM0, PWM1 XT2	I <sub>OL</sub> =10mA	4.5 to 5.5			1.5	
	V <sub>OL</sub> (5)		I <sub>OL</sub> =1.6mA	3.0 to 5.5			0.4	
	V <sub>OL</sub> (6)		I <sub>OL</sub> =1mA	2.7 to 5.5			0.4	
	V <sub>OL</sub> (7)	Ports 3, 7	I <sub>OL</sub> =1.6mA	3.0 to 5.5			0.4	
	V <sub>OL</sub> (8)		I <sub>OL</sub> =1mA	2.7 to 5.5			0.4	
Pull-up resistance	R <sub>pu</sub> (1)	Ports 0, 1, 2, 3	V <sub>OH</sub> =0.9V <sub>DD</sub>	4.5 to 5.5	15	35	80	kΩ
	R <sub>pu</sub> (2)	Port 7		2.7 to 5.5	18	50	150	
Hysteresis voltage	V <sub>HYS</sub>	$\overline{\text{RES}}$ Ports 1, 2, 3, 7		2.7 to 5.5		0.1V <sub>DD</sub>		V
Pin capacitance	CP	All pins	For pins other than that under test: V <sub>IN</sub> =V <sub>SS</sub> f=1MHz Ta=25°C	2.7 to 5.5		10		pF

Note 3-1: When the CKO system clock output function (P05) or audio interface output function (P05 to P07) is used.

# LC871HC4A/92A

**Serial I/O Characteristics** at Ta = -40°C to +85°C, V<sub>SS1</sub> = V<sub>SS2</sub> = V<sub>SS3</sub> = 0V

## 1. SIO0 Serial I/O Characteristics (Note 4-1-1)

Parameter		Symbol	Pin/ Remarks	Conditions	V <sub>DD</sub> [V]	Specification						
						min	typ	max	unit			
Serial clock	Input clock	Frequency	tSCK(1)	SCK0(P12)	2.7 to 5.5				tCYC			
		Low level pulse width	tSCKL(1)	<ul style="list-style-type: none"> <li>• Continuous data transfer mode</li> <li>• USB, AIF, SIO4, SIO9, and DMCOPY not used at the same time.</li> <li>• See Fig. 8.</li> <li>• (Note 4-1-2)</li> </ul>						2		
		High level pulse width	tSCKH(1)							1		
			tSCKHA(1a)							1		
		tSCKHA(1b)	4									
		tSCKHA(1c)	7									
	Output clock	Frequency	tSCK(2)	SCK0(P12)	2.7 to 5.5				tCYC			
		Low level pulse width	tSCKL(2)	<ul style="list-style-type: none"> <li>• When CMOS output type is selected</li> <li>• See Fig. 8.</li> </ul>						4/3		
		High level pulse width	tSCKH(2)							1/2		tSCK
			tSCKHA(2a)							1/2		
tSCKHA(2b)	<ul style="list-style-type: none"> <li>• Continuous data transfer mode</li> <li>• USB, AIF, SIO4, SIO9, and DMCOPY not used at the same time.</li> <li>• When CMOS output type is selected</li> <li>• See Fig. 8.</li> </ul>	tSCKH(2) + 2tCYC		tSCKH(2) + (10/3)tCYC								
tSCKHA(2c)	<ul style="list-style-type: none"> <li>• Continuous data transfer mode</li> <li>• USB, AIF, SIO4, SIO9, and DMCOPY used at the same time</li> <li>• When CMOS output type is selected</li> <li>• See Fig. 8.</li> </ul>	tSCKH(2) + 2tCYC		tSCKH(2) + (19/3)tCYC								
		tSCKH(2) + 2tCYC		tSCKH(2) + (25/3)tCYC								

Note 4-1-1: These specifications are theoretical values. Margins must be allowed according to the actual operating conditions.

Note 4-1-2: In an application where the serial clock input is to be used in the continuous data transfer mode, the time from SIORUN being set when serial clock is high to the falling edge of the first serial clock must be longer than tSCKHA.

Continued on next page.



# LC871HC4A/92A

Continued from preceding page.

Parameter		Symbol	Pin/ Remarks	Conditions	V <sub>DD</sub> [V]	Specification			
						min	typ	max	unit
Serial input	Data setup time	tsDI(1)	SB0(P11), SI0(P11)	<ul style="list-style-type: none"> <li>Must be specified with respect to rising edge of SIOCLK.</li> <li>See Fig. 8.</li> </ul>	2.7 to 5.5	0.03			
	Data hold time	thDI(1)				0.03			
Serial output	Output delay time	tdD0(1)	SO0(P10), SB0(P11)	<ul style="list-style-type: none"> <li>Continuous data transfer mode</li> <li>(Note 4-1-3)</li> </ul>	2.7 to 5.5			(1/3)t <sub>CYC</sub> +0.05	μs
		tdD0(2)				<ul style="list-style-type: none"> <li>Synchronous 8-bit mode</li> <li>(Note 4-1-3)</li> </ul>			
	Output clock	tdD0(3)		(Note 4-1-3)				(1/3)t <sub>CYC</sub> +0.05	

Note 4-1-3: Must be specified with respect to falling edge of SIOCLK.

Must be specified as the time to the beginning of output state change in open drain output mode. See Fig. 8.

## 2. SIO1 Serial I/O Characteristics (Note 4-2-1)

Parameter		Symbol	Pin/ Remarks	Conditions	V <sub>DD</sub> [V]	Specification				
						min	typ	max	unit	
Serial clock	Input clock	Frequency	tSCK(3)	SCK1(P15)	See Fig. 8.	2.7 to 5.5	2			t <sub>CYC</sub>
		Low level pulse width	tSCKL(3)				1			
		High level pulse width	tSCKH(3)				1			
	Output clock	Frequency	tSCK(4)	SCK1(P15)	<ul style="list-style-type: none"> <li>When CMOS output type is selected</li> <li>See Fig. 8.</li> </ul>	2.7 to 5.5	2			t <sub>SCK</sub>
		Low level pulse width	tSCKL(4)				1/2			
		High level pulse width	tSCKH(4)				1/2			
Serial input	Data setup time	tsDI(2)	SB1(P14), SI1(P14)	<ul style="list-style-type: none"> <li>Must be specified with respect to rising edge of SIOCLK.</li> <li>See Fig. 8.</li> </ul>	2.7 to 5.5	0.03				
	Data hold time	thDI(2)				0.03				
Serial output	Output delay time	tdD0(4)	SO1(P13), SB1(P14)	<ul style="list-style-type: none"> <li>Must be specified with respect to falling edge of SIOCLK.</li> <li>Must be specified as the time to the beginning of output state change in open drain output mode.</li> <li>See Fig. 8.</li> </ul>	2.7 to 5.5			(1/3)t <sub>CYC</sub> +0.05	μs	

Note 4-2-1: These specifications are theoretical values. Margins must be allowed according to the actual operating conditions.

# LC871HC4A/92A

## 3. SIO4 Serial I/O Characteristics (Note 4-3-1)

Parameter	Symbol	Pin/ Remarks	Conditions	V <sub>DD</sub> [V]	Specification					
					min	typ	max	unit		
Serial clock	Input clock	Frequency	tSCK(5)	SCK4(P24)	See Fig. 8.	2.7 to 5.5	2			tCYC
		Low level pulse width	tSCKL(5)				1			
		High level pulse width	tSCKH(5)				1			
			tSCKHA(5a)				4			
		tSCKHA(5b)	7							
		tSCKHA(5c)					12			
	Output clock	Frequency	tSCK(6)	SCK4(P24)	When CMOS output type is selected. See Fig. 8.	2.7 to 5.5		4/3		
		Low level pulse width	tSCKL(6)				1/2			
		High level pulse width	tSCKH(6)				1/2			
			tSCKHA(6a)				tSCKH(6) + (5/3)tCYC	tSCKH(6) + (10/3)tCYC	tCYC	
		tSCKHA(6b)	tSCKH(6) + (5/3)tCYC				tSCKH(6) + (19/3)tCYC			
		tSCKHA(6c)	tSCKH(6) + (5/3)tCYC				tSCKH(6) + (34/3)tCYC			
Serial input	Data setup time	tsDI(3)	S04(P22), SI4(P23)	Must be specified with respect to falling edge of SIOCLK. See Fig. 8	2.7 to 5.5	0.03			μs	
	Data hold time	thDI(3)				0.03				
Serial output	Output delay time	tdD0(5)	S04(P22), SI4(P23)	Must be specified with respect to rising edge of SIOCLK. Must be specified as the time to the beginning of output state change in open drain output mode. See Fig. 8.	2.7 to 5.5			(1/3)tCYC +0.05	μs	

Note 4-3-1: These specifications are theoretical values. Margins must be allowed according to the actual operating conditions.

Note 4-3-2: In an application where the serial clock input is to be used in the continuous data transfer mode, the time from SI4RUN being set when serial clock is high to the falling edge of the first serial clock must be longer than tSCKHA.

# LC871HC4A/92A

## 4. SIO9 Serial I/O Characteristics (Note 4-4-1)

Parameter	Symbol	Pin/ Remarks	Conditions	V <sub>DD</sub> [V]	Specification					
					min	typ	max	unit		
Serial clock	Input clock	Frequency	tSCK(7)	SCK9(P27)	See Fig. 8.	2.7 to 5.5	2			tCYC
		Low level pulse width	tSCKL(7)				1			
		High level pulse width	tSCKH(7)				1			
			tSCKHA(7a)				4			
			tSCKHA(7b)							
		tSCKHA(7c)	15							
	Output clock	Frequency	tSCK(8)	<ul style="list-style-type: none"> <li>• When CMOS output type is selected.</li> <li>• See Fig. 8.</li> </ul>	2.7 to 5.5	4/3			tSCK	
		Low level pulse width	tSCKL(8)			1/2				
		High level pulse width	tSCKH(8)			1/2				
		tSCKHA(8a)	tSCKH(8)			tSCKH(8) + (5/3)tCYC	tSCKH(8) + (10/3)tCYC	tCYC		
			tSCKHA(8b)			tSCKH(8) + (5/3)tCYC	tSCKH(8) + (19/3)tCYC			
			tSCKHA(8c)			tSCKH(8) + (5/3)tCYC	tSCKH(8) + (43/3)tCYC			
Serial input	Data setup time	tsDI(4)	SO9(P25), S19(P26)	2.7 to 5.5	0.03					
	Data hold time	thDI(4)								
Serial output	Output delay time	tdDO(6)	SO9(P25), S19(P26)	2.7 to 5.5			(1/3)tCYC + 0.05	μs		

Note 4-4-1: These specifications are theoretical values. Margins must be allowed according to the actual operating conditions.

Note 4-4-2: In an application where the serial clock input is to be used in the continuous data transfer mode, the time from SI9RUN being set when serial clock is high to the falling edge of the first serial clock must be longer than tSCKHA.

## LC871HC4A/92A

### Pulse Input Conditions at Ta = -40°C to +85°C, VSS1 = VSS2 = VSS3 = 0V

Parameter	Symbol	Pin/Remarks	Conditions	Specification				
				VDD[V]	min	typ	max	unit
High/low level pulse width	tP1H(1) tP1L(1)	INT0(P70), INT1(P71), INT2(P72), INT4(P20 to P23), INT5(P24 to P27), INT6(P20), INT7(P24)	<ul style="list-style-type: none"> <li>Interrupt source flag can be set.</li> <li>Event inputs for timer 0 or 1 are enabled.</li> </ul>	2.7 to 5.5	1			tCYC
	tPIH(2) tPIL(2)	INT3(P73) when noise filter time constant is 1/1	<ul style="list-style-type: none"> <li>Interrupt source flag can be set.</li> <li>Event inputs for timer 0 are enabled.</li> </ul>	2.7 to 5.5	2			
	tPIH(3) tPIL(3)	INT3(P73) when noise filter time constant is 1/32	<ul style="list-style-type: none"> <li>Interrupt source flag can be set.</li> <li>Event inputs for timer 0 are enabled.</li> </ul>	2.7 to 5.5	64			
	tPIH(4) tPIL(4)	INT3(P73) when noise filter time constant is 1/128	<ul style="list-style-type: none"> <li>Interrupt source flag can be set.</li> <li>Event inputs for timer 0 are enabled.</li> </ul>	2.7 to 5.5	256			
	tPIL(5)	RMIN(P73)	Recognized by the infrared remote control receiver circuit as a signal	2.7 to 5.5	4			RMCK (Note 5-1)
	tPIL(6)	RES	Resetting is enabled.	2.7 to 5.5	200			μs

Note 5-1: Represents the period of the reference clock (1 tCYC to 128 tCYC or the source frequency of the subclock) for the infrared remote control receiver circuit.

### AD Converter Characteristics at Ta = -40°C to +85°C, VSS1 = VSS2 = VSS3 = 0V

Parameter	Symbol	Pin/Remarks	Conditions	Specification				
				VDD[V]	min	typ	max	unit
Resolution	N	AN0(P00) to AN7(P07), AN8(P70), AN9(P71), AN10(XT1), AN11(XT2)		3.0 to 5.5		8		bit
Absolute accuracy	ET		(Note 6-1)	3.0 to 5.5			±1.5	LSB
Conversion time	TCAD		AD conversion time=32×tCYC (when ADCR2=0) (Note 6-2)	4.5 to 5.5	15.68 (tCYC= 0.490μs)		97.92 (tCYC= 3.06μs)	μs
				3.0 to 5.5	23.52 (tCYC= 0.735μs)		97.92 (tCYC= 3.06μs)	
			AD conversion time=64×tCYC (when ADCR2=1) (Note 6-2)	4.5 to 5.5	18.82 (tCYC= 0.294μs)		97.92 (tCYC= 1.53μs)	
				3.0 to 5.5	47.04 (tCYC= 0.735μs)		97.92 (tCYC= 1.53μs)	
Analog input voltage range	VAIN			3.0 to 5.5	VSS		VDD	V
Analog port input current	IAINH		VAIN=VDD	3.0 to 5.5			1	μA
	IAINL		VAIN=VSS	3.0 to 5.5	-1			

Note 6-1: The quantization error ( $\pm 1/2\text{LSB}$ ) is excluded from the absolute accuracy.

Note 6-2: The conversion time refers to the period from the time when an instruction for starting a conversion process is issued to the time the conversion results register(s) are loaded with a complete digital conversion value corresponding to the analog input value.

# LC871HC4A/92A

## Consumption Current Characteristics at Ta = -40°C to +85°C, VSS1 = VSS2 = VSS3 = 0V

Parameter	Symbol	Pin/ Remarks	Conditions	Specification				
				VDD[V]	min	typ	max	unit
Normal mode consumption current (Note 7-1)	IDDOP(1)	VDD1 =VDD2 =VDD3	<ul style="list-style-type: none"> <li>FmCF=12MHz ceramic oscillation mode</li> <li>FsX'tal=32.768kHz crystal oscillation mode</li> <li>System clock set to 12MHz side</li> <li>Internal PLL oscillation stopped</li> <li>Internal RC oscillation stopped</li> <li>USB circuit stopped</li> <li>1/1 frequency division ratio</li> </ul>	4.5 to 5.5		9.8	24	mA
	IDDOP(2)		<ul style="list-style-type: none"> <li>Internal PLL oscillation stopped</li> <li>Internal RC oscillation stopped</li> <li>USB circuit stopped</li> <li>1/1 frequency division ratio</li> </ul>	3.0 to 3.6		5.7	14	
	IDDOP(3)		<ul style="list-style-type: none"> <li>FmCF=12MHz ceramic oscillation mode</li> <li>FsX'tal=32.768kHz crystal oscillation mode</li> <li>System clock set to 12MHz side</li> <li>Internal PLL oscillation mode active</li> <li>Internal RC oscillation stopped</li> <li>USB circuit active</li> <li>1/1 frequency division ratio</li> </ul>	4.5 to 5.5		15	35	
	IDDOP(4)		<ul style="list-style-type: none"> <li>Internal PLL oscillation mode active</li> <li>Internal RC oscillation stopped</li> <li>USB circuit active</li> <li>1/1 frequency division ratio</li> </ul>	3.0 to 3.6		7.7	20	
	IDDOP(5)		<ul style="list-style-type: none"> <li>FmCF=12MHz ceramic oscillation mode</li> <li>FsX'tal=32.768kHz crystal oscillation mode</li> <li>System clock set to 6MHz side</li> <li>Internal RC oscillation stopped</li> <li>1/2 frequency division ratio</li> </ul>	4.5 to 5.5		6.7	16	
	IDDOP(6)		<ul style="list-style-type: none"> <li>System clock set to 6MHz side</li> <li>Internal RC oscillation stopped</li> <li>1/2 frequency division ratio</li> </ul>	3.0 to 3.6		3.9	9.0	
	IDDOP(7)		<ul style="list-style-type: none"> <li>Internal RC oscillation stopped</li> <li>1/2 frequency division ratio</li> </ul>	2.7 to 3.0		3.2	7.3	
	IDDOP(8)		<ul style="list-style-type: none"> <li>FmCF=0Hz(oscillation stopped)</li> <li>FsX'tal=32.768kHz crystal oscillation mode</li> <li>System clock set to internal RC oscillation.</li> <li>1/2 frequency division ratio</li> </ul>	4.5 to 5.5		0.72	3.4	
	IDDOP(9)		<ul style="list-style-type: none"> <li>FsX'tal=32.768kHz crystal oscillation mode</li> <li>System clock set to internal RC oscillation.</li> <li>1/2 frequency division ratio</li> </ul>	3.0 to 3.6		0.41	1.9	
	IDDOP(10)		<ul style="list-style-type: none"> <li>1/2 frequency division ratio</li> </ul>	2.7 to 3.0		0.35	1.5	
	IDDOP(11)		<ul style="list-style-type: none"> <li>FmCF=0Hz(oscillation stopped)</li> <li>FsX'tal=32.768kHz crystal oscillation mode</li> <li>System clock set to crystal oscillation.</li> </ul>	4.5 to 5.5		45	184	
	IDDOP(12)		<ul style="list-style-type: none"> <li>System clock set to crystal oscillation.</li> </ul>	3.0 to 3.6		18	65	
	IDDOP(13)		<ul style="list-style-type: none"> <li>Internal RC oscillation stopped</li> <li>1/2 frequency division ratio</li> </ul>	2.7 to 3.0		14	47	
HALT mode consumption current (Note7-1)	IDDHALT(1)		<ul style="list-style-type: none"> <li>HALT mode</li> <li>FmCF=12MHz ceramic oscillation mode</li> <li>FsX'tal=32.768kHz crystal oscillation mode</li> <li>System clock set to 12MHz side</li> <li>Internal PLL oscillation stopped</li> <li>Internal RC oscillation stopped</li> <li>USB circuit stopped</li> <li>1/1 frequency division ratio</li> </ul>	4.5 to 5.5		4.9	12	mA
	IDDHALT(2)		<ul style="list-style-type: none"> <li>Internal PLL oscillation stopped</li> <li>Internal RC oscillation stopped</li> <li>USB circuit stopped</li> <li>1/1 frequency division ratio</li> </ul>	3.0 to 3.6		2.7	6.4	
	IDDHALT(3)		<ul style="list-style-type: none"> <li>HALT mode</li> <li>FmCF=12MHz ceramic oscillation mode</li> <li>FsX'tal=32.768kHz crystal oscillation mode</li> <li>System clock set to 12MHz side</li> <li>Internal PLL oscillation mode active</li> <li>Internal RC oscillation stopped</li> <li>USB circuit active</li> <li>1/1 frequency division ratio</li> </ul>	4.5 to 5.5		9.5	23	
	IDDHALT(4)		<ul style="list-style-type: none"> <li>Internal PLL oscillation mode active</li> <li>Internal RC oscillation stopped</li> <li>USB circuit active</li> <li>1/1 frequency division ratio</li> </ul>	3.0 to 3.6		4.7	12	
	IDDHALT(5)		<ul style="list-style-type: none"> <li>HALT mode</li> <li>FmCF=12MHz ceramic oscillation mode</li> <li>FsX'tal=32.768kHz crystal oscillation mode</li> <li>System clock set to 6MHz side</li> <li>Internal RC oscillation stopped</li> <li>1/2 frequency division ratio</li> </ul>	4.5 to 5.5		3.0	7.3	
	IDDHALT(6)		<ul style="list-style-type: none"> <li>System clock set to 6MHz side</li> <li>Internal RC oscillation stopped</li> <li>1/2 frequency division ratio</li> </ul>	3.0 to 3.6		1.6	3.8	
	IDDHALT(7)		<ul style="list-style-type: none"> <li>Internal RC oscillation stopped</li> <li>1/2 frequency division ratio</li> </ul>	2.7 to 3.0		1.3	2.9	
	IDDHALT(8)		<ul style="list-style-type: none"> <li>HALT mode</li> <li>FmCF=0Hz(oscillation stopped)</li> <li>FsX'tal=32.768kHz crystal oscillation mode</li> <li>System clock set to internal RC oscillation.</li> <li>1/2 frequency division ratio</li> </ul>	4.5 to 5.5		0.41	2.0	
	IDDHALT(9)		<ul style="list-style-type: none"> <li>FsX'tal=32.768kHz crystal oscillation mode</li> <li>System clock set to internal RC oscillation.</li> <li>1/2 frequency division ratio</li> </ul>	3.0 to 3.6		0.20	0.95	
	IDDHALT(10)		<ul style="list-style-type: none"> <li>1/2 frequency division ratio</li> </ul>	2.7 to 3.0		0.17	0.70	

Note 7-1: The consumption current value includes none of the currents that flow into the output Tr and internal pull-up resistors.

Continued on next page.

# LC871HC4A/92A

Continued from preceding page.

Parameter	Symbol	Pin/ Remarks	Conditions	Specification				
				V <sub>DD</sub> [V]	min	typ	max	unit
HALT mode consumption current (Note 7-1)	IDDHALT(11)	V <sub>DD1</sub> =V <sub>DD2</sub> =V <sub>DD3</sub>	<ul style="list-style-type: none"> <li>• HALT mode</li> <li>• FmCF=0MHz (oscillation stopped)</li> <li>• FsX'tal=32.768kHz crystal oscillation mode (32.768kHz)</li> <li>• System clock set to crystal oscillation.</li> <li>• Internal RC oscillation stopped</li> <li>• 1/2 frequency division ratio</li> </ul>	4.5 to 5.5		31	132	μA
	IDDHALT(12)			3.0 to 3.6		9.1	39	
	IDDHALT(13)			2.7 to 3.0		6.3	27	
HOLD mode consumption current	IDDHOLD(1)	V <sub>DD1</sub>	<ul style="list-style-type: none"> <li>• HOLD mode</li> <li>• CF1=V<sub>DD</sub> or open (External clock mode)</li> </ul>	4.5 to 5.5		0.14	39	
	IDDHOLD(2)			3.0 to 3.6		0.04	19	
	IDDHOLD(3)			2.7 to 3.0		0.04	17	
Timer HOLD mode consumption current	IDDHOLD(4)		<ul style="list-style-type: none"> <li>• Timer HOLD mode</li> <li>• CF1=V<sub>DD</sub> or open (External clock mode)</li> <li>• FsX'tal=32.768kHz crystal oscillation mode</li> </ul>	4.5 to 5.5		25	115	
	IDDHOLD(5)			3.0 to 3.6		6.0	32	
	IDDHOLD(6)			2.7 to 3.0		3.7	20	

Note 7-1: The consumption current value includes none of the currents that flow into the output Tr and internal pull-up resistors

## USB Characteristics and Timing at Ta = -40°C to +85°C, V<sub>SS1</sub> = V<sub>SS2</sub> = V<sub>SS3</sub> = 0V

Parameter	Symbol	Conditions	Specification			
			min	typ	max	unit
High level output	V <sub>OH(USB)</sub>	• 15kΩ±5% to GND	2.8		3.6	V
Low level output	V <sub>OL(USB)</sub>	• 1.5kΩ±5% to 3.6V	0.0		0.3	V
Output signal crossover voltage	V <sub>CRS</sub>		1.3		2.0	V
Differential input sensitivity	V <sub>DI</sub>	•  (UHD+)-(UHD-)	0.2			V
Differential input common mode range	V <sub>CM</sub>		0.8		2.5	V
High level input	V <sub>IH(USB)</sub>		2.0			V
Low level input	V <sub>IL(USB)</sub>				0.8	V
USB data rise time	t <sub>R</sub>	• R <sub>S</sub> =33Ω, C <sub>L</sub> =50pF	4		20	ns
USB data fall time	t <sub>F</sub>	• R <sub>S</sub> =33Ω, C <sub>L</sub> =50pF	4		20	ns

### Characteristics of a Sample Main System Clock Oscillation Circuit

Given below are the characteristics of a sample main system clock oscillation circuit that are measured using a SANYO-designated oscillation characteristics evaluation board and external components with circuit constant values with which the oscillator vendor confirmed normal and stable oscillation.

Table 1 shows the characteristics of a oscillation circuit when USB host function is not used.

If USB host function is to be used, it is absolutely recommended to use an oscillator that satisfies the precision and stability according to the USB standards.

Table 1 Characteristics of a Sample Main System Clock Oscillator Circuit with a Ceramic Oscillator

Nominal Frequency	Vendor Name	Oscillator Name	Circuit Constant			Operating Voltage Range [V]	Oscillation Stabilization Time		Remarks
			C1 [pF]	C2 [pF]	Rd1 [ $\Omega$ ]		typ [ms]	max [ms]	
6MHz	MURATA	CSTCR6M00GH5L**-R0	(39)	(39)	1k	2.7 to 5.5	0.1	0.5	C1 and C2 integrated SMD type
8MHz	MURATA	CSTCE8M00GH5L**-R0	(33)	(33)	470	3.0 to 5.5	0.1	0.5	
10MHz	MURATA	CSTCE10M0GH5L**-R0	(33)	(33)	330	3.0 to 5.5	0.1	0.5	
12MHz	MURATA	CSTCE12M0GH5L**-R0	(33)	(33)	330	3.0 to 5.5	0.1	0.5	

The oscillation stabilization time refers to the time interval that is required for the oscillation to get stabilized in the following cases (see Figure 4):

- Till the oscillation gets stabilized after  $V_{DD}$  goes above the operating voltage lower limit.
- Till the oscillation gets stabilized after the instruction for starting the main clock oscillation circuit is executed
- Till the oscillation gets stabilized after the HOLD mode is reset.
- Till the oscillation gets stabilized after the X'tal HOLD mode is reset with CFSTOP (OCR register, bit 0) set to 0

### Characteristics of a Sample Subsystem Clock Oscillator Circuit

Given below are the characteristics of a sample subsystem clock oscillation circuit that are measured using a SANYO-designated oscillation characteristics evaluation board and external components with circuit constant values with which the oscillator vendor confirmed normal and stable oscillation.

Table 2 Characteristics of a Sample Subsystem Clock Oscillator Circuit with a Crystal Oscillator

Nominal Frequency	Vendor Name	Oscillator Name	Circuit Constant				Operating Voltage Range [V]	Oscillation Stabilization Time		Remarks
			C3 [pF]	C4 [pF]	Rf [ $\Omega$ ]	Rd2 [ $\Omega$ ]		typ [s]	max [s]	
32.768kHz	EPSON TOYOCOM	MC-306	18	18	OPEN	560k	2.7 to 5.5	1.1	3.0	Applicable CL value=12.5pF SMD type

The oscillation stabilization time refers to the time interval that is required for the oscillation to get stabilized in the following cases (see Figure 4):

- Till the oscillation gets stabilized after the instruction for starting the subclock oscillation circuit is executed
- Till the oscillation gets stabilized after the HOLD mode is reset with EXTOSC (OCR register, bit 6) set to 1

Note: The components that are involved in oscillation should be placed as close to the IC and to one another as possible because they are vulnerable to the influences of the circuit pattern.

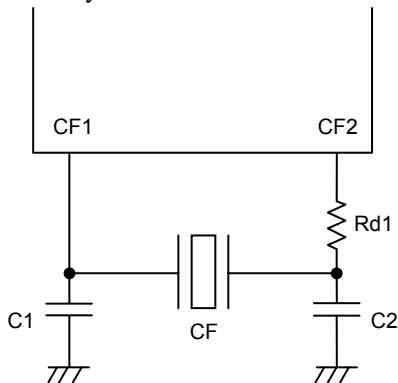

Figure 1 CF Oscillator Circuit

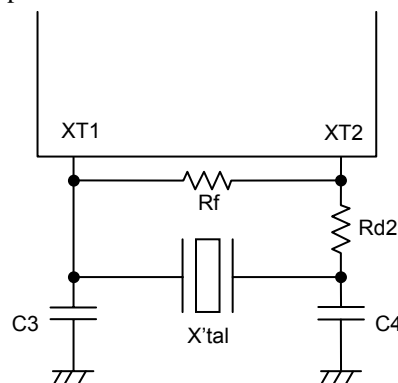

Figure 2 Crystal Oscillator Circuit

**LC871HC4A/92A**

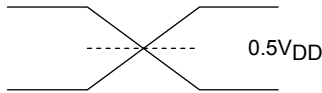
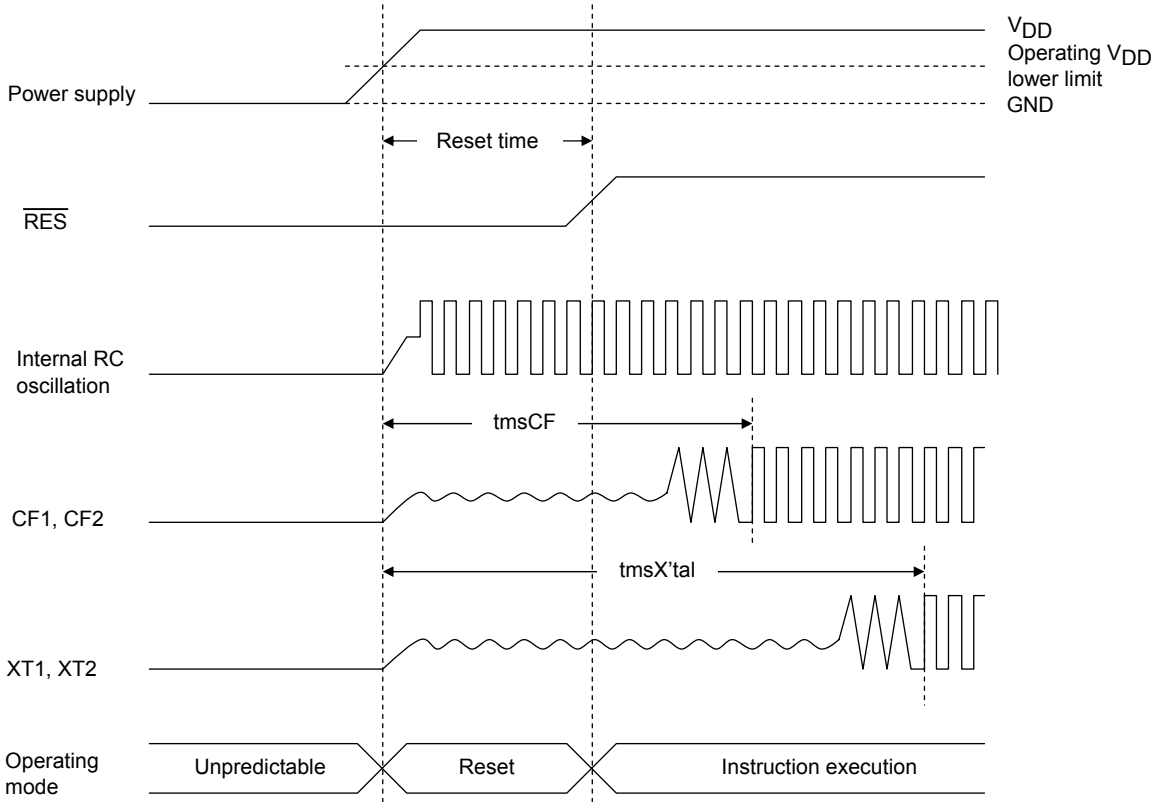
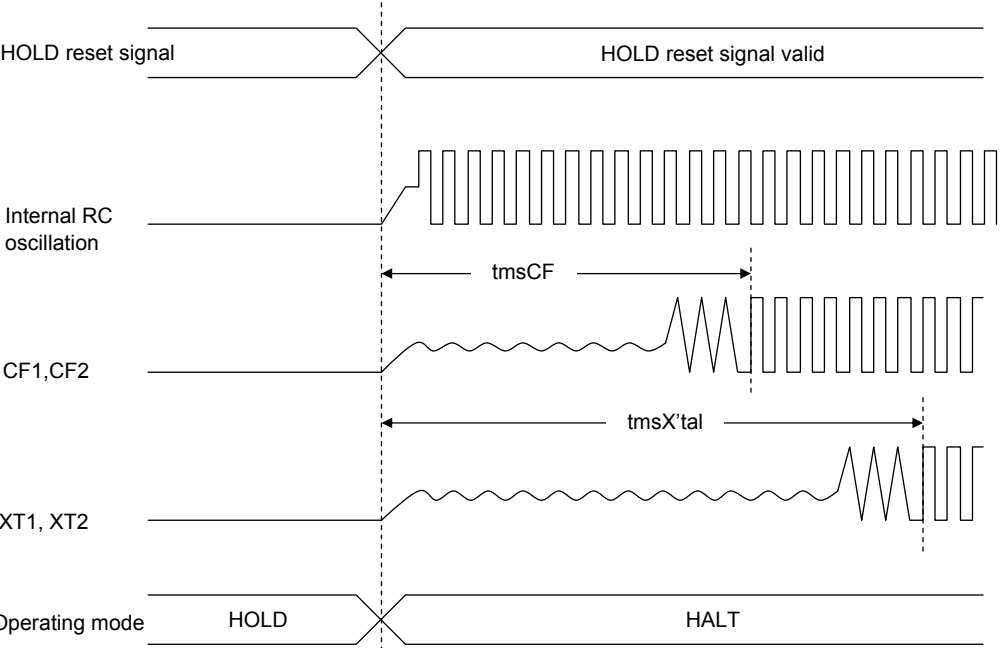

Figure 3 AC Timing Measurement Point



**Reset Time and Oscillation Stabilization Time**



**HOLD Reset Signal and Oscillation Stabilization Time**

Figure 4 Oscillation Stabilization Time



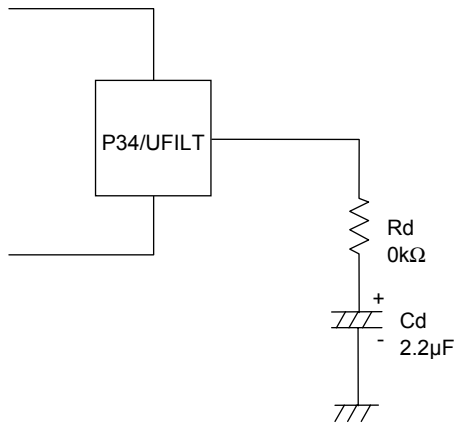

When using the internal PLL circuit to generate the 48MHz clock for USB , it is necessary to connect a filter circuit such to the P34/UFILT pin such as that shown in the left Fig.

Figure 5 External Filter Circuit for the Internal USB-dedicated PLL Circuit

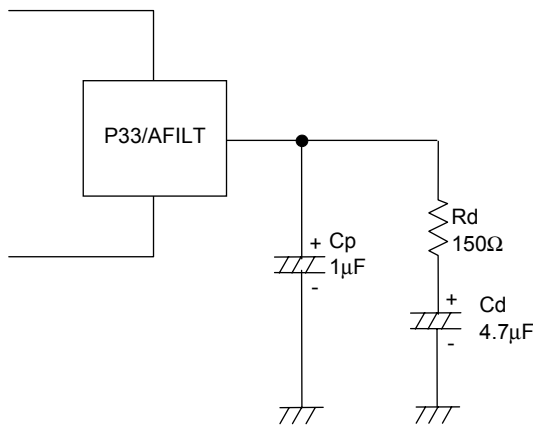

To generate the master clock for the audio interface using the internal PLL circuit, it is necessary to connect a filter circuit to the P33/AFILT pin that is shown in the left Fig.

Figure 6 External Filter Circuit for Audio Interface (Used with Internal PLL Circuit)

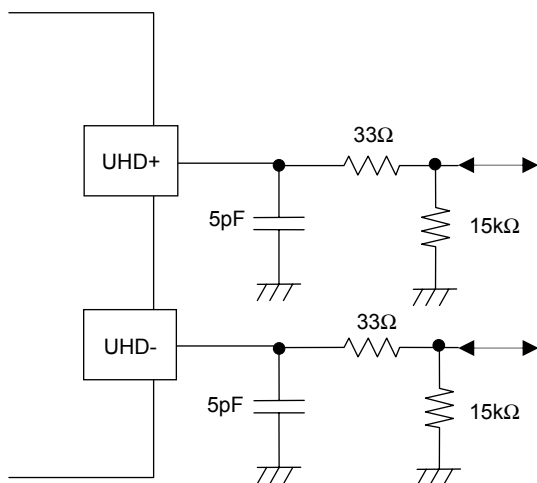

It's necessary to adjust the Circuit Constant of the USB Port Peripheral Circuit for each mounting board.

Figure 7 USB Port Peripheral Circuit

# LC871HC4A/92A

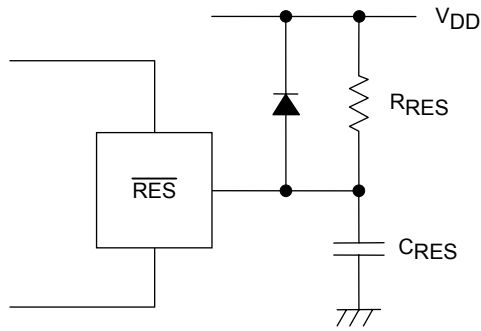

Note:  
 Determine the value of  $C_{RES}$  and  $R_{RES}$  so that the reset signal is present for a period of  $200\mu s$  after the supply voltage goes beyond the lower limit of the IC's operating voltage.

Figure 8 Reset Circuit

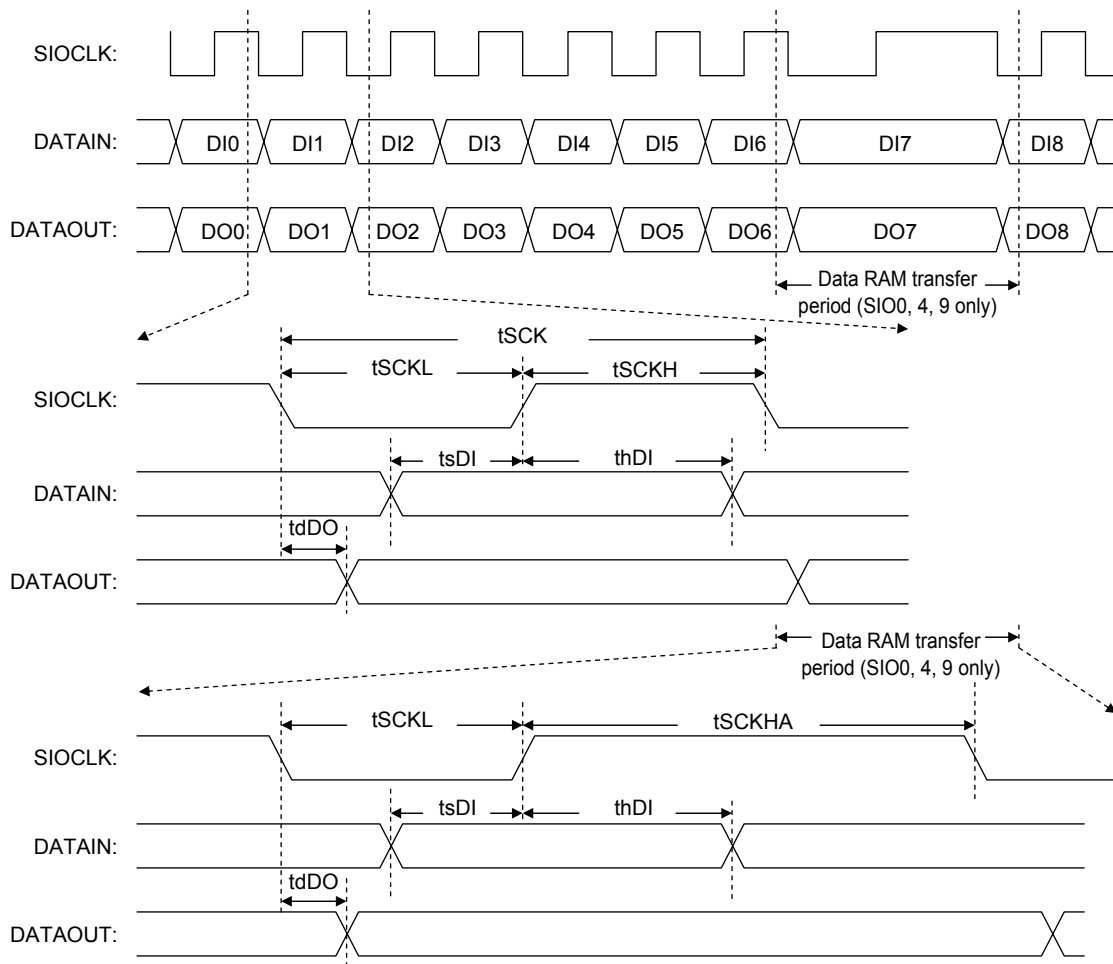

Figure 9 Serial Input/Output Waveform

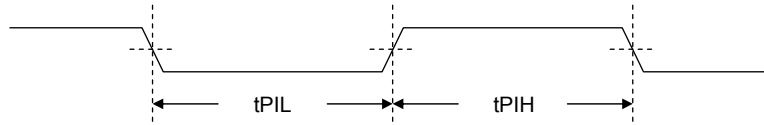

Figure 10 Pulse Input Timing Signal Waveform

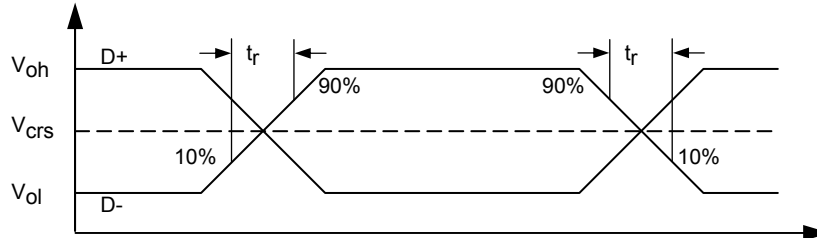

Figure 11 USB Data Signal Timing and Voltage Level

- SANYO Semiconductor Co.,Ltd. assumes no responsibility for equipment failures that result from using products at values that exceed, even momentarily, rated values (such as maximum ratings, operating condition ranges, or other parameters) listed in products specifications of any and all SANYO Semiconductor Co.,Ltd. products described or contained herein.
- SANYO Semiconductor Co.,Ltd. strives to supply high-quality high-reliability products, however, any and all semiconductor products fail or malfunction with some probability. It is possible that these probabilistic failures or malfunction could give rise to accidents or events that could endanger human lives, trouble that could give rise to smoke or fire, or accidents that could cause damage to other property. When designing equipment, adopt safety measures so that these kinds of accidents or events cannot occur. Such measures include but are not limited to protective circuits and error prevention circuits for safe design, redundant design, and structural design.
- In the event that any or all SANYO Semiconductor Co.,Ltd. products described or contained herein are controlled under any of applicable local export control laws and regulations, such products may require the export license from the authorities concerned in accordance with the above law.
- No part of this publication may be reproduced or transmitted in any form or by any means, electronic or mechanical, including photocopying and recording, or any information storage or retrieval system, or otherwise, without the prior written consent of SANYO Semiconductor Co.,Ltd.
- Any and all information described or contained herein are subject to change without notice due to product/technology improvement, etc. When designing equipment, refer to the "Delivery Specification" for the SANYO Semiconductor Co.,Ltd. product that you intend to use.
- Information (including circuit diagrams and circuit parameters) herein is for example only; it is not guaranteed for volume production.
- Upon using the technical information or products described herein, neither warranty nor license shall be granted with regard to intellectual property rights or any other rights of SANYO Semiconductor Co.,Ltd. or any third party. SANYO Semiconductor Co.,Ltd. shall not be liable for any claim or suits with regard to a third party's intellectual property rights which has resulted from the use of the technical information and products mentioned above.

This catalog provides information as of April, 2008. Specifications and information herein are subject to change without notice.