

P 1200 A ... P 1200 S

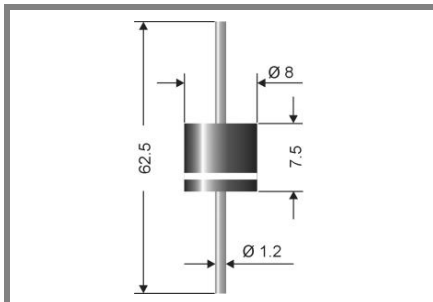

Axial lead diode

Standard silicon rectifier diodes

P 1200 A ... P 1200 S

Forward Current: 12 A

Reverse Voltage: 50 to 1200 V

Features

- Max. solder temperature: 260°C
- Plastic material has UL classification 94V-0

Mechanical Data

- Plastic case: 8 x 7,5 [mm] / P-600 Style
- Weight approx.: 1,5 g
- Terminals: plated terminals solderable per MIL-STD-750
- Mounting position: any
- Standard packaging: 500 pieces per ammo

1) Valid, if leads are kept at ambient temperature at a distance of 10 mm from case

2) $I_F = 5 \text{ A}$, $T_J = 25 \text{ °C}$

3) $T_A = 25 \text{ °C}$

Type	Repetitive peak reverse voltage V_{RRM} V	Surge peak reverse voltage V_{RSM} V	Max. reverse recovery time $I_F = -A$ $I_R = -A$ $I_{RR} = -A$ t_{rr} ns	Max. forward voltage $V_F^{2)}$
P 1200 A	50	50	-	0,84
P 1200 B	100	100	-	0,84
P 1200 D	200	200	-	0,84
P 1200 G	400	400	-	0,84
P 1200 J	600	600	-	0,88
P 1200 K	800	800	-	0,88
P 1200 M	1000	1000	-	0,88
P 1200 S	1200	1200	-	0,88

Absolute Maximum Ratings

$T_A = 25 \text{ °C}$, unless otherwise specified

Symbol	Conditions	Values	Units
I_{FAV}	Max. averaged fwd. current, R-load, $T_A = 50 \text{ °C}^1)$	12	A
I_{FRM}	Repetitive peak forward current $f > 15 \text{ Hz}^1)$	80	A
I_{FSM}	Peak forward surge current 50 Hz half sinus-wave $^3)$	600	A
i^2t	Rating for fusing, $t < 10 \text{ ms}^3)$	1800	A ² s
R_{thA}	Max. thermal resistance junction to ambient $^1)$	10	K/W
R_{thT}	Max. thermal resistance junction to terminals $^1)$		K/W
T_J	Operating junction temperature	-50 ... +150	°C
T_s	Storage temperature	-50 ... +150	°C

Characteristics

$T_A = 25 \text{ °C}$, unless otherwise specified

Symbol	Conditions	Values	Units
I_R	Maximum leakage current, $T_J = 25 \text{ °C}$; $V_R = V_{RRM}$	<25	μA
	$T_J = \text{°C}$; $V_R = V_{RRM}$		
C_J	Typical junction capacitance (at MHz and applied reverse voltage of V)	-	pF
Q_{rr}	Reverse recovery charge ($U_R = V$; $I_F = A$; $dI_F/dt = A/ms$)	-	μC
E_{RSM}	Non repetitive peak reverse avalanche energy ($I_R = mA$; $T_J = \text{°C}$; inductive load switched off)	-	mJ

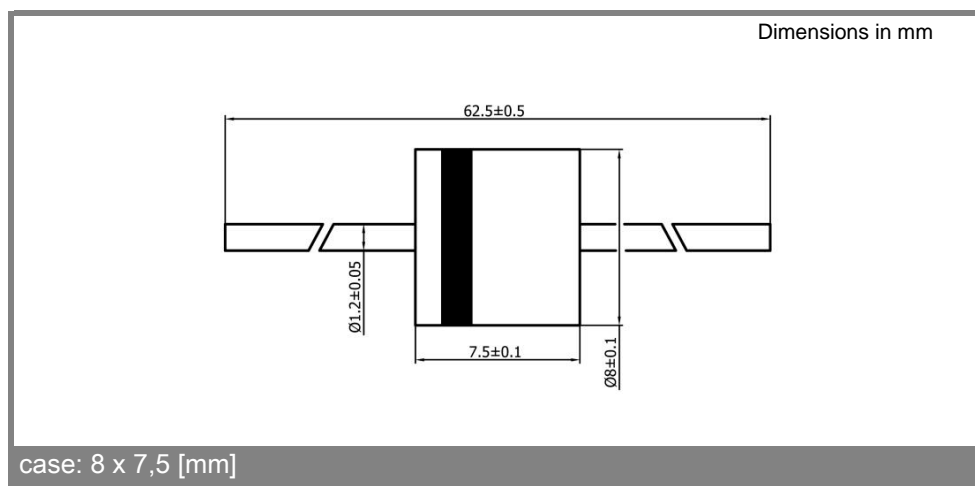

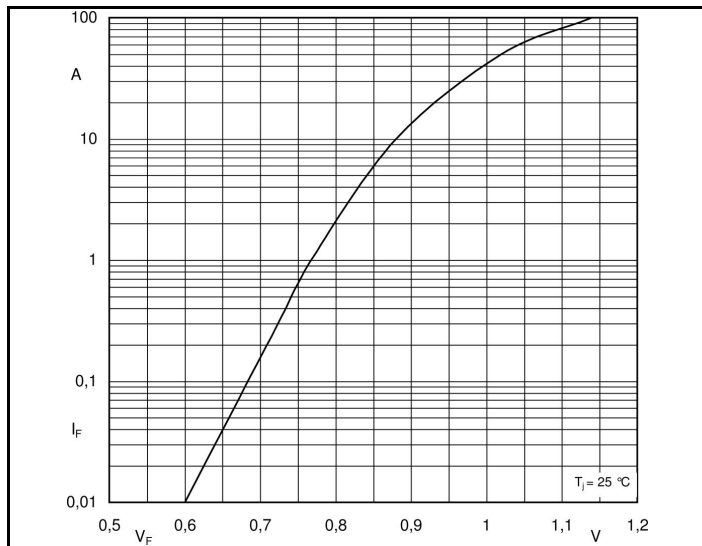

Fig. 1 Forward characteristics (typical values)

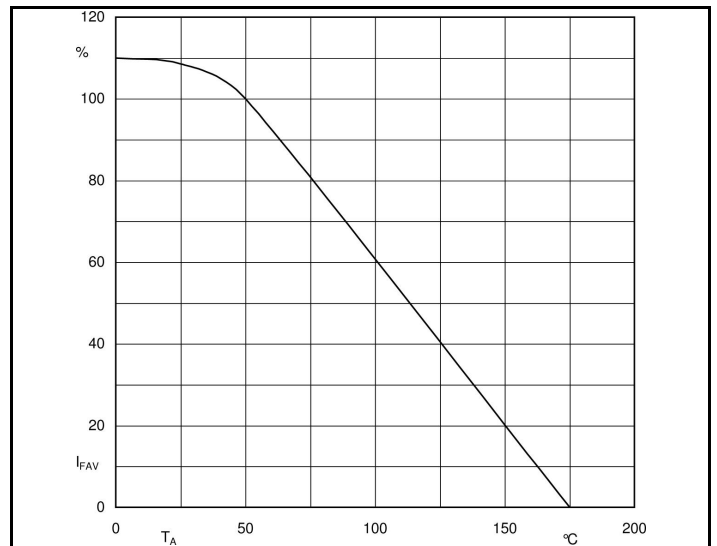

Fig. 2 Rated forward current vs. ambient temperature ¹⁾

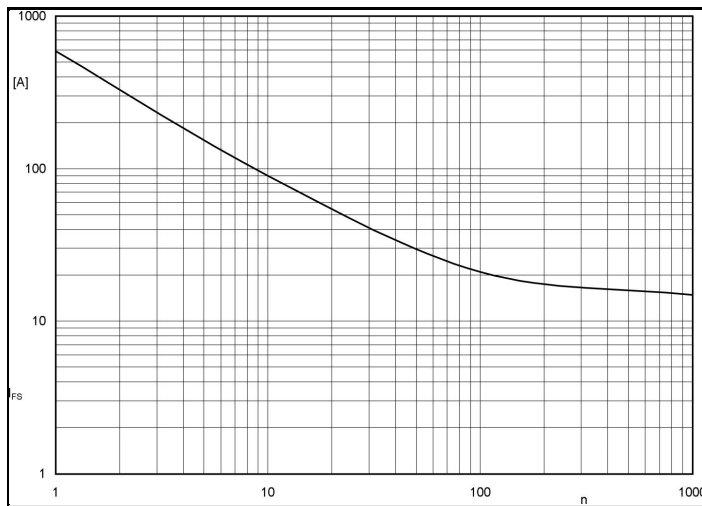

Fig. 3 I_{FSM} current versus number of cycles at 50 Hz