

## GaAs SPDT 2.7 V High Power Switch DC - 5.0 GHz

Rev. V2

### Features

- Low Voltage Operation: 2.7 V
- High Power: +38dBm (typ) P0.1dB
- High IP3: +56 dBm
- Low Insertion Loss: 0.25 dB @ 1 GHz
- High Isolation: 25 dB @ 1 GHz
- Lead-Free SC70 Package
- 100% Matte Tin Plating over Copper
- Halogen-Free "Green" Mold Compound
- RoHS\* Compliant and 260°C Reflow Compatible

### Description

M/A-COM's MASW-008853 is a GaAs PHEMT MMIC single pole double throw (SPDT) high power switch in a low cost SC70 six lead package. The MASW-008853 is ideally suited for applications where high power, low control voltage, low insertion loss, high isolation, small size, and low cost are required.

Typical applications are for CDMA handset systems that connect separate transceiver and/or GPS functions to a common antenna, as well as other related handset and general purpose applications. The MASW-008853 can be used in all systems operating up to 5.0 GHz requiring high power at low control voltage.

The MASW-008853 is fabricated using a 0.5 micron gate length GaAs pHEMT process. The process features full passivation for performance and reliability.

### Ordering Information <sup>1,2</sup>

Part Number	Package
MASW-008853-000000	Bulk Packaging
MASW-008853-TR3000	3000 piece reel
MASW-008853-001SMB	Sample Test Board

1. Reference Application Note M513 for reel size information.
2. All sample boards include 5 loose parts.

### Functional Block Diagram

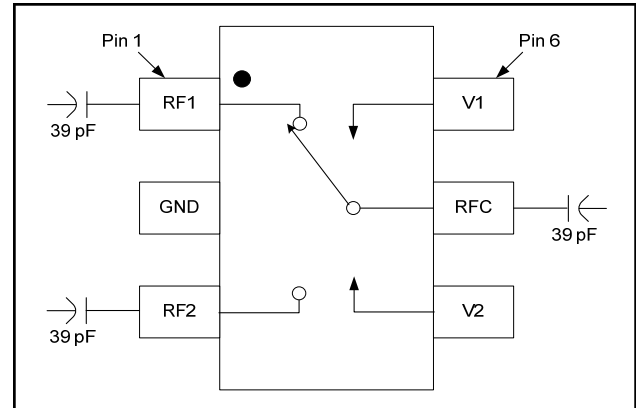

### Pin Configuration

Pin No.	Pin Name	Description
1	RF1	RF Port 1
2	GND	RF Ground
3	RF2	RF Port 2
4	V2	Vcontrol 2
5	RFC	RF Common
6	V1	Vcontrol 1

### Absolute Maximum Ratings <sup>3,4</sup>

Parameter	Absolute Maximum
Input Power (0.5 - 3 GHz, 3 V Control)	+38 dBm
Operating Voltage	+8.5 volts
Operating Temperature	-40°C to +85°C
Storage Temperature	-65°C to +150°C

3. Exceeding any one or combination of these limits may cause permanent damage to this device.
4. M/A-COM does not recommend sustained operation near these survivability limits.

\* Restrictions on Hazardous Substances, European Union Directive 2002/95/EC.

## GaAs SPDT 2.7 V High Power Switch DC - 5.0 GHz

Rev. V2

### Electrical Specifications: $T_A = 25^\circ\text{C}$ , $V_C = 0\text{ V}/2.7\text{ V}$ , $Z_0 = 50\ \Omega$ <sup>5</sup>

Parameter	Test Conditions	Units	Min.	Typ.	Max.
Insertion Loss <sup>6</sup>	1 GHz	dB	—	0.30	0.65
	2 GHz	dB	—	0.36	—
	3 GHz	dB	—	0.45	—
	4 GHz	dB	—	0.70	—
	5 GHz	dB	—	1.10	—
Isolation	1 GHz	dB	23	25	—
	2 GHz	dB	—	19	—
	3 GHz	dB	—	15	—
	4 GHz	dB	—	13	—
	5 GHz	dB	—	11	—
Return Loss	DC – 3 GHz	dB	—	20	—
IP3	825 MHz Two Tone, +24 dBm Total Pin, 5 MHz Spacing	dBm	—	56	—
Cross Modulation	Two-tone signal input: Tx1 = +22 dBm @ 820 MHz, Tx2 = +22 dBm @ 821 MHz, R <sub>x</sub> interfere = -23 dBm @ 869 MHz	dBm	—	-99	—
	Two-tone signal input: Tx1 = +18 dBm @ 1880 MHz, Tx2 = +18 dBm @ 1881 MHz, R <sub>x</sub> interfere = -23 dBm @ 1960 MHz	dBm	—	-94	—
P0.1dB	1 GHz	dBm	—	38	—
Trise, Tfall	10% to 90% RF, 90% to 10% RF	nS	—	70	—
Ton, Toff	50% control to 90% RF, 50% control to 10% RF	nS	—	100	—
Transients	In Band	mV	—	25	—
Control Current	$V_C = 2.7\text{ V}$	$\mu\text{A}$	—	5	20

5. For positive voltage control, external DC blocking capacitors are required on all RF ports.

6. Insertion loss can be optimized by varying the DC blocking capacitor value, e.g. 1000 pF for 100 MHz - 1 GHz, 39 pF for 0.5 GHz - 3 GHz.

### Truth Table<sup>7,8,9</sup>

V1	V2	ANT- RF1	ANT - RF2
1	0	On	Off
0	1	Off	On

7. For positive voltage control, external DC blocking capacitors are required on all RF ports.

8. Differential voltage,  $V(\text{state } 1) - V(\text{state } 0)$ , must be +2.7 V minimum, but must not exceed 8.5 V.

9. 0 = -5 V to +2.3 V, 1 = -2.3 V to +5 V.

### Qualification

Qualified to M/A-COM specification REL-201, Process Flow -2.

### Handling Procedures

Please observe the following precautions to avoid damage:

### Static Sensitivity

Gallium Arsenide Integrated Circuits are sensitive to electrostatic discharge (ESD) and can be damaged by static electricity. Proper ESD control techniques should be used when handling these devices.

- **North America** Tel: 800.366.2266 / Fax: 978.366.2266
  - **Europe** Tel: 44.1908.574.200 / Fax: 44.1908.574.300
  - **Asia/Pacific** Tel: 81.44.844.8296 / Fax: 81.44.844.8298
- Visit [www.macomtech.com](http://www.macomtech.com) for additional data sheets and product information.

M/A-COM Technology Solutions Inc. and its affiliates reserve the right to make changes to the product(s) or information contained herein without notice.

### Typical Performance Curves, 1000 pF

**Insertion Loss**

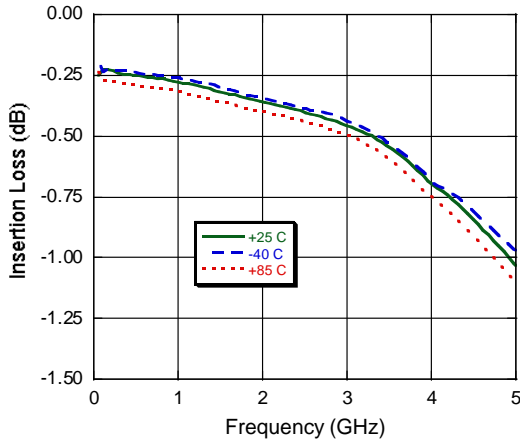

**Isolation**

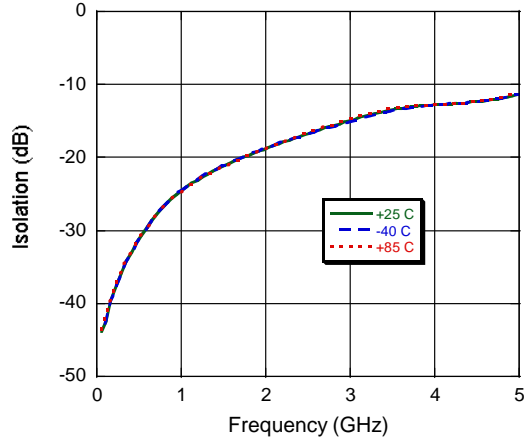

**RF Return Loss**

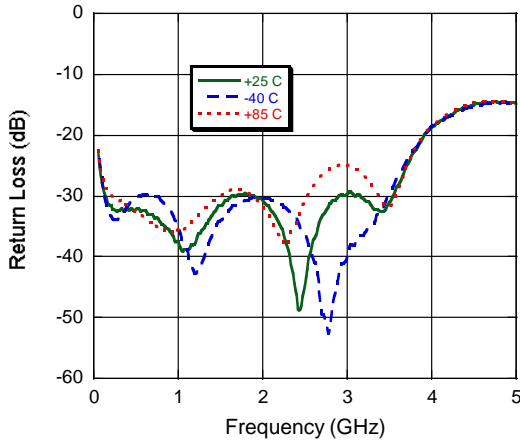

**RF1/RF2 Return Loss**

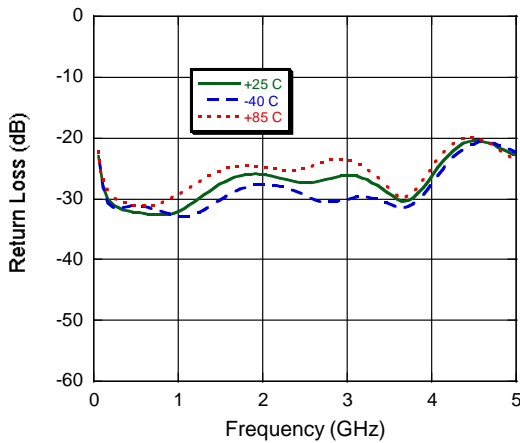

### Lead-Free SC70 Plastic Package<sup>†</sup>

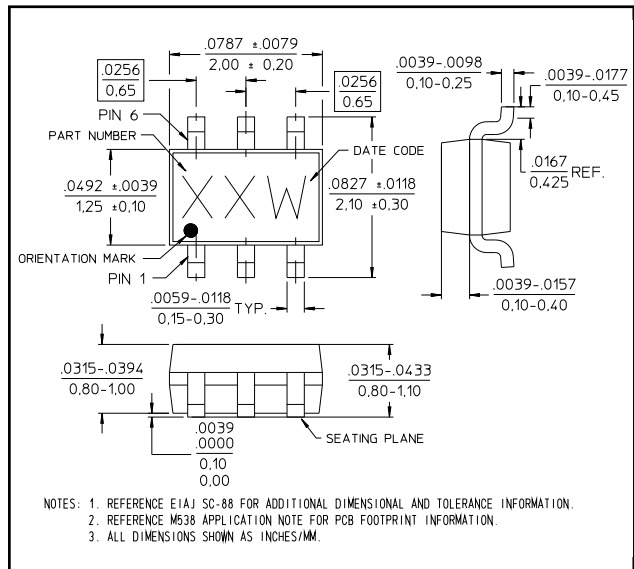

<sup>†</sup> Reference Application Note M538 for lead-free solder reflow recommendations.  
Meets JEDEC moisture sensitivity level 1 requirements.