



Features

- ◇ For GSM IF SAW filter
- ◇ High attenuation
- ◇ Single-ended operation
- ◇ Dual In-line Package
- ◇ No matching required for operation at 50Ω
- ◇ RoHS compliant (2002/95/EC), Pb-free

Specifications

Parameter		Unit	Minimum	Typical	Maximum
Center Frequency		MHz	69.99	71	71.016
Insertion Loss		dB	-	18	21
2.3 dB Bandwidth		MHz	0.2	0.21	-
2.5 dB Bandwidth		MHz	-	0.22	-
3 dB Bandwidth		MHz	-	0.24	-
45 dB Bandwidth		MHz	-	0.74	0.8
Passband Variation		dB	-	0.1	0.5
Group Delay Variation($f_0 \pm 0.1\text{MHz}$)		nsec	-	230	500
Absolute Delay		usec	-	3.72	4
Ultimate Rejection	$f_0 \pm 0.4\text{MHz}$	dB	45	55	-
	$f_0 \pm 0.6\text{MHz}$	dB	55	59	-
	$f_0 \pm 1\text{MHz}$	dB	60	62	-
Material Temperature coefficient		KHz/°C	0.071		
Substrate Material		-	ST QZ		
Ambient Temperature		°C	25		
Operating Temperature Range		°C	-40	-	+85
Storage Temperature Range		°C	-45	-	+105
DC Voltage		V	0		
Input Power		dBm	-	-	10
ESD Class		-	1		
Package Size		DIP3512 (35.0x12.8x4.7mm3)			

Notes:

1. All specifications are based on the test circuit shown;
2. In production, all specifications are measured by Agilent Network analyzer and full 2 port calibration at room temperature;
3. Electrical margin has been built into the design to account for the variations due to temperature drift and manufacturing tolerances;
4. This is the optimum impedance in order to achieve the performance show.

	SIPAT Co., Ltd. (CETC No.26 Research Institute) #14 Nanping Huayuan Road, Chongqing, China, 400060	Part Number	LBS07107	
		Rev. Date	2008-05-27	
		Ver.	1.0	Page

Matching Configuration



Source/Load Impedance=50 ohm

Notes - Component values may change depending on board layout.

Package Dimension

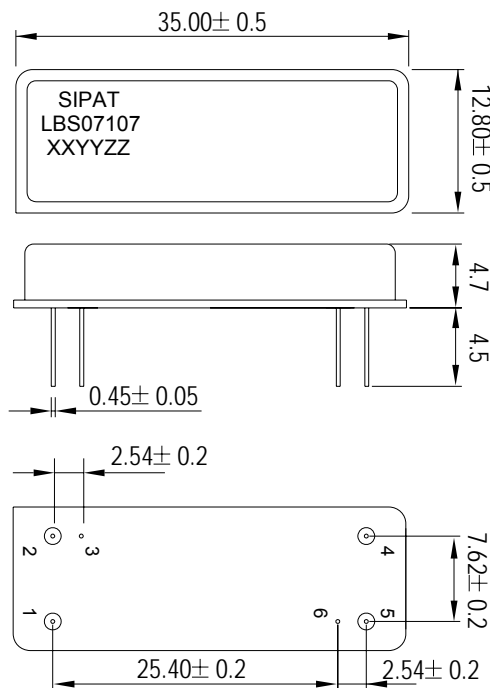

Pad Configuration:

Input 1
Output 5
Ground All Others

Marking Configuration:

- 1) SIPAT: Manufacturer Name
- 2) LBS07107: Part Number
- 3) XXYY: Date(Year/month)
- 4) ZZ: Identified Code

Package: DIP3512

Unit: mm



SIPAT Co., Ltd.
(CETC No.26 Research Institute)
#14 Nanping Huayuan Road,
Chongqing, China, 400060

Part Number	LBS07107	
Rev. Date	2008-05-27	
Ver.	1.0	Page 2/3

Typical Performance

Frequency Respond

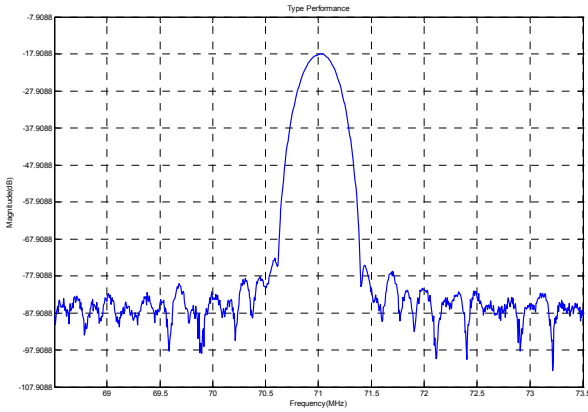

Horizontal: 0.5MHz/Div Vertical: 10dB/Div

Passband Respond

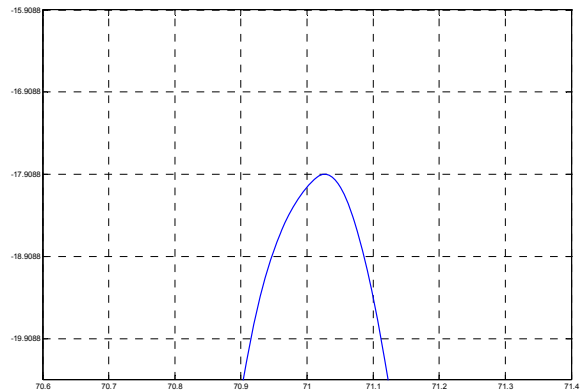

Horizontal: 0.1MHz/Div Vertical: 1dB/Div

Group Delay Variation(f0±0.1MHz)

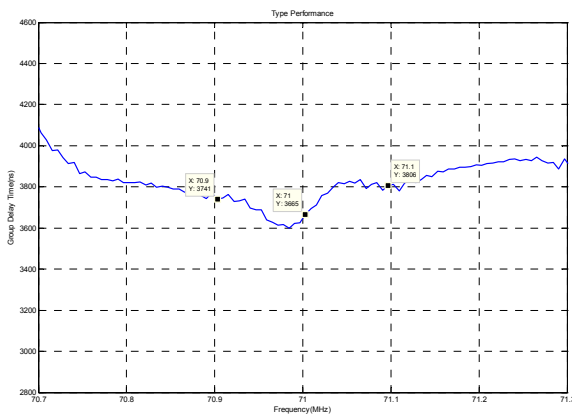

Horizontal: 0.1MHz/Div Vertical: 200ns/Div

Phase Linearity(f0±0.1MHz)

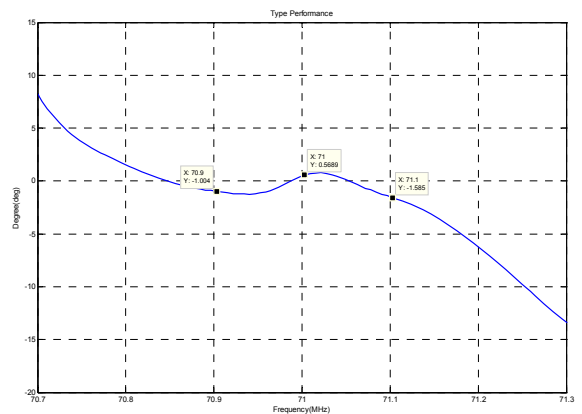

Horizontal: 0.1MHz/Div Vertical: 5deg/Div

Smith Chart S11

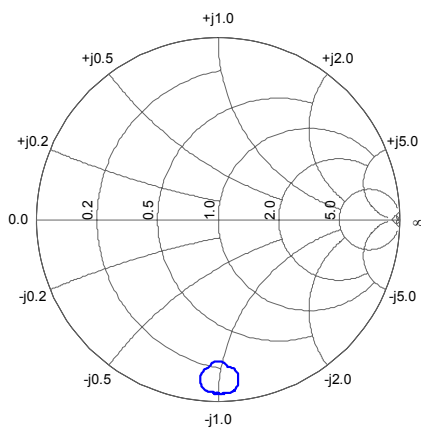

Smith Chart S22

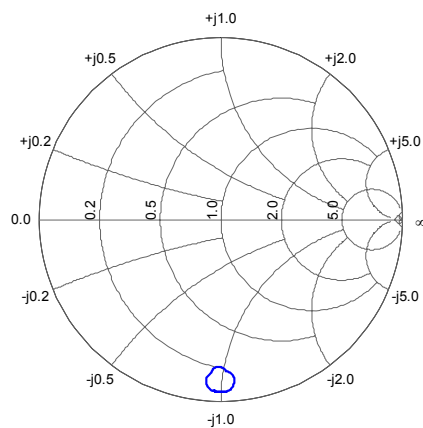

SIPAT Co., Ltd.
(CETC No.26 Research Institute)
#14 Nanping Huayuan Road,
Chongqing, China, 400060

Part Number	LBS07107	
Rev. Date	2008-05-27	
Ver.	1.0	Page 3/3