

## General Description

The AAT3123/23A/24 is a low noise, constant frequency charge pump DC/DC converter that uses a dual mode load switch (1X) and fractional (1.5X) conversion to maximize efficiency for white LED applications. The device can be used to produce current levels up to 20mA to drive up to six LEDs from a 2.7V to 5.5V input. Outputs may be operated individually or paralleled for driving higher-current LEDs. A low external parts count (two 1µF flying capacitors and two small 1µF capacitors at V<sub>IN</sub> and OUT) make the AAT3123/23A/24 ideally suited for small battery-powered applications.

AnalogicTech's Simple Serial Control™ (S<sup>2</sup>Cwire™) interface is used to enable, disable, and set the LED drive current with a 32-level logarithmic scale LED brightness control. The AAT3123/23A/24 has a thermal management system to protect the device in the event of a short-circuit condition at the output pin. Built-in soft-start circuitry prevents excessive inrush current during start-up. A high charge pump switching frequency enables the use of very small external capacitors. A low-current shutdown feature disconnects the load from V<sub>IN</sub> and reduces quiescent current to less than 1µA. The device also integrates a test current/auto-disable feature for each channel. The AAT3123/23A is available in a very small, Pb-free 12-pin TSOPJW package. The six output AAT3124 is available in the Pb-free 16-pin 4x4mm QFN and 14-pin TSOPJW packages.

## Features

- V<sub>IN</sub> Range: 2.7V to 5.5V
- Dual Mode 1X and 1.5X Charge Pump for Maximum Efficiency
- Drives Low-V<sub>F</sub> and High-V<sub>F</sub> Type LEDs
- Up to Six 20mA Outputs (AAT3124)
- Up to Four 20mA Outputs (AAT3123/23A)
- 32-Position Logarithmic Scale with Digital Control
- Simple Serial Control (S<sup>2</sup>Cwire) Interface
- Low Noise Constant Frequency Operation
- 1MHz Switching Frequency
- Small Application Circuit
- Regulated Output Current
- Automatic Soft Start
- No Inductors
- I<sub>Q</sub> < 1µA in Shutdown
- Temperature Range: -40°C to +85°C
- 12-Pin TSOPJW Package (AAT3123/23A)
- 16-Pin 4x4mm QFN and 14-Pin TSOPJW Packages (AAT3124)

## Applications

- Color (RGB) Lighting
- Programmable Current Source
- White LED Backlighting
- White Photo Flash for DSCs

## Typical Application

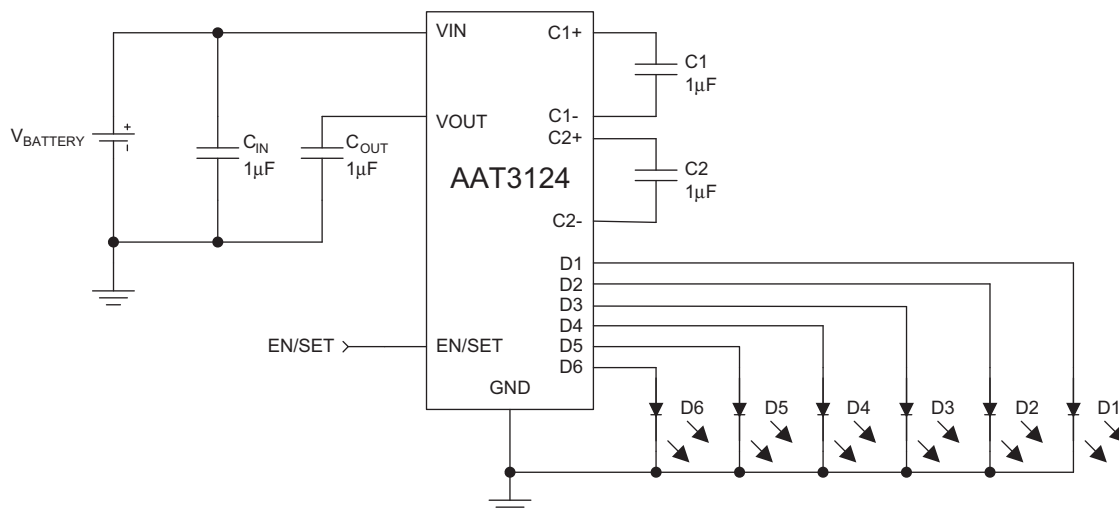

## Pin Descriptions

Pin #			Symbol	Function
AAT3123/23A (TSOPJW-12)	AAT3124 (QFN44-16)	AAT3124 (TSOPJW-14)		
1	10	8	C2+	Flying capacitor 2 positive terminal. Connect a 1μF capacitor between C2+ and C2-.
2	9	9	OUT	Charge pump output. Requires 1μF capacitor connected between this pin and ground.
3	7	10	C1-	Flying capacitor 1 negative terminal.
4	6	11	C1+	Flying capacitor 1 positive terminal. Connect a 1μF capacitor between C1+ and C1-.
5	5	12	D4	Current source output #4.
6	4	13	D3	Current source output #3.
7	1	2	D2	Current source output #2.
8	16	3	D1	Current source output #1.
9	15	4	EN/SET	Control pin using S <sup>2</sup> Cwire serial interface.
10	14	5	IN	Input power supply. Requires 1μF capacitor connected between this pin and ground.
11	12	6	GND	Ground.
12	11	7	C2-	Flying capacitor 2 negative terminal.
	2	1	D5	Current source output #5.
	3	14	D6	Current source output #6.
	8, 13		N/C	No connection.
	EP			Exposed paddle (bottom); connect to GND directly beneath package.

## Pin Configuration

**TSOPJW-12  
(Top View)**

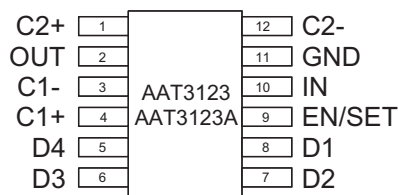

**QFN44-16  
(Top View)**

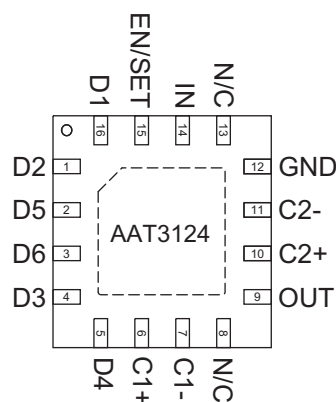

**TSOPJW-14  
(Top View)**

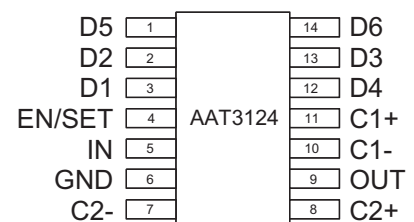

### Absolute Maximum Ratings<sup>1</sup>

Symbol	Description	Value	Units
$V_{IN}$	Input Voltage	-0.3 to 6	V
$V_{OUT}$	Charge Pump Output	-0.3 to 6	V
FB, $V_{EN/SET}$	FB or EN/SET to GND Voltage	-0.3 to 6	V
$V_{EN/SET(MAX)}$	Maximum EN/SET to Input Voltage	0.3	V
$I_{OUT}^2$	Maximum DC Output Current	150	mA
$T_J$	Operating Junction Temperature Range	-40 to 150	°C

### Thermal Information<sup>3</sup>

Symbol	Description	Value	Units
$\theta_{JA}$	Thermal Resistance	QFN44-16	50
		TSOPJW-12	160
$P_D$	Maximum Power Dissipation	QFN44-16 <sup>4</sup>	2.0
		TSOPJW-12 <sup>5</sup>	0.625

1. Stresses above those listed in Absolute Maximum Ratings may cause permanent damage to the device. Functional operation at conditions other than the operating conditions specified is not implied. Only one Absolute Maximum Rating should be applied at any one time.

2. Based on long-term current density limitation.

3. Mounted on an FR4 board.

4. Derate 20mW/°C above 25°C.

5. Derate 6.25mW/°C above 25°C.

**ChargePump™ High Efficiency 1X/1.5X Fractional Charge Pump for White LED Applications**

## Electrical Characteristics<sup>1</sup>

$C_{IN} = C_{OUT} = C_1 = C_2 = 1.0\mu\text{F}$ ;  $T_A = -40^\circ\text{C}$  to  $+85^\circ\text{C}$ , unless otherwise noted. Typical values are  $T_A = 25^\circ\text{C}$ ,  $V_{IN} = 3.5\text{V}$ .

Symbol	Description	Conditions	Min	Typ	Max	Units
<b>Input Power Supply</b>						
$V_{IN}$	Operation Range		2.7		5.5	V
$I_{CC}$	Operating Current	$3.0 \leq V_{IN} \leq 5.5$ , Active, No Load Current		1.8	3.5	mA
$I_{SHDN(MAX)}$	Shutdown Current	EN = 0			1	$\mu\text{A}$
$I_{DX}$	Output Current	$V_{IN} = 3.5\text{V}$ , Code = 32, $T_A = 25^\circ\text{C}$	18	20	22	mA
$I_{(D-Match)}$	Current Matching Between Any Two Outputs	VD1:D4 = 3.6V, $V_{IN} = 3.5\text{V}$		0.5		%
		VD5:VD6 = 3.6V, $V_{IN} = 3.5\text{V}$		0.5		
$\eta_{CP}$	Charge Pump Section Efficiency	$V_{IN} = 3.5\text{V}$ , $I_{OUT(TOTAL)} = 120\text{mA}$ , Measured from IN to OUT		93		%
<b>Charge Pump Section</b>						
$T_{SS}$	Soft-Start Time			200		$\mu\text{s}$
$F_{CLK}$	Clock Frequency			1000		kHz
<b>EN/SET</b>						
$V_{EN(L)}$	Enable Threshold Low	$V_{IN} = 2.7\text{V}$ to $5.5\text{V}$			0.5	V
$V_{EN(H)}$	Enable Threshold High	$V_{IN} = 2.7\text{V}$ to $5.5\text{V}$	1.4			V
$T_{EN/SET LO}$	EN/SET Low Time		0.3		75	$\mu\text{s}$
$T_{EN/SET HI}$	Minimum EN/SET High Time			50		ns
$T_{OFF}$	EN/SET Off Timeout				500	$\mu\text{s}$
Input Current	EN/SET Input Leakage		-1		1	$\mu\text{A}$

1. The AAT3123/4 is guaranteed to meet performance specifications over the  $-40^\circ\text{C}$  to  $+85^\circ\text{C}$  operating temperature range and is assured by design, characterization, and correlation with statistical process controls.

## Typical Characteristics

Unless otherwise noted,  $V_{IN} = 3.5V$ ,  $C_{IN} = C_{OUT} = C_1 = C_2 = 1\mu F$ ,  $T_A = 25^\circ C$ .

**Efficiency vs. Input Voltage (4x20mA)**

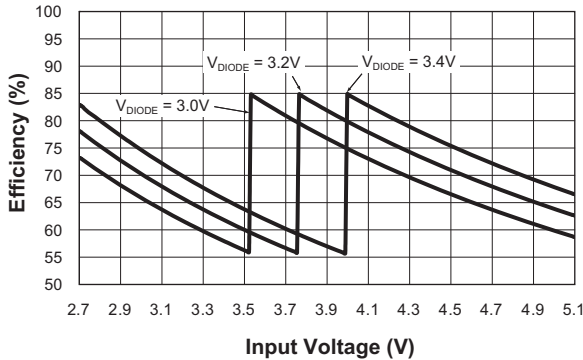

**Efficiency vs. Input Voltage (4x10mA)**

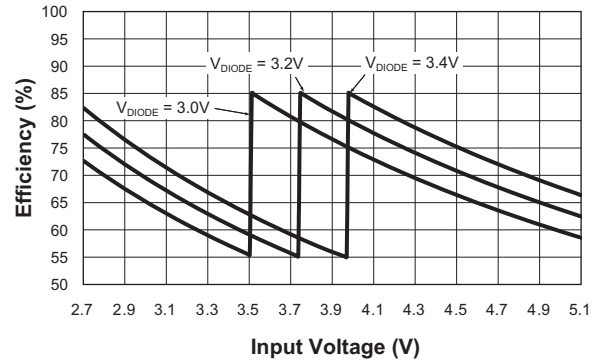

**$I_{DIODE}$  vs. Input Voltage (4x20mA)**

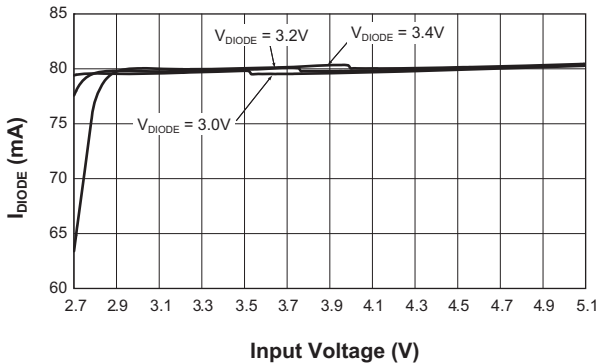

**$I_{DIODE}$  vs. Input Voltage (4x10mA)**

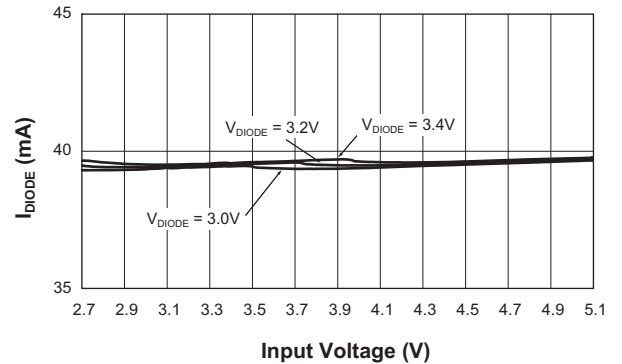

**Quiescent Current vs. Input Voltage**

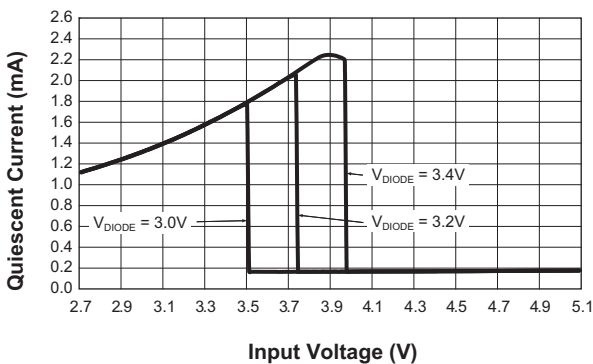

**$V_{IH}$  and  $V_{IL}$  vs.  $V_{IN}$**

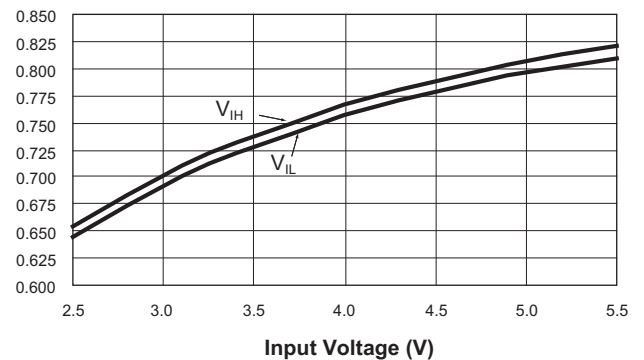

## Typical Characteristics

Unless otherwise noted,  $V_{IN} = 3.5V$ ,  $C_{IN} = C_{OUT} = C_1 = C_2 = 1\mu F$ ,  $T_A = 25^\circ C$ .

Turn-On to Full-Scale Charge Pump

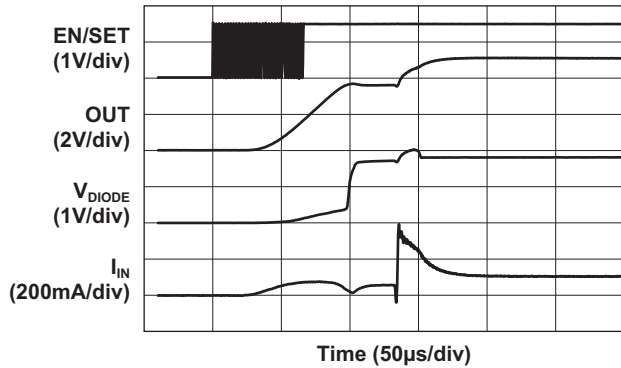

Turn-On to Full-Scale Load Switch

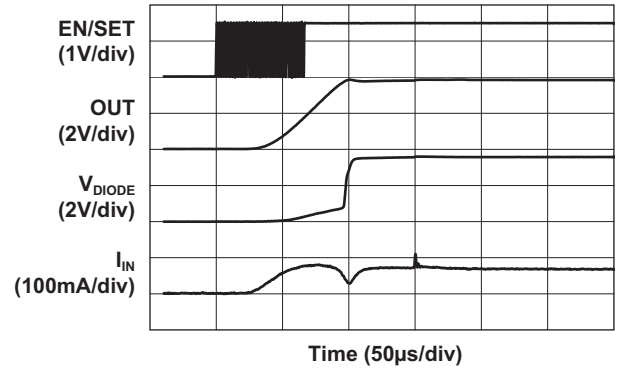

Charge Pump to Load Switch (80mA)

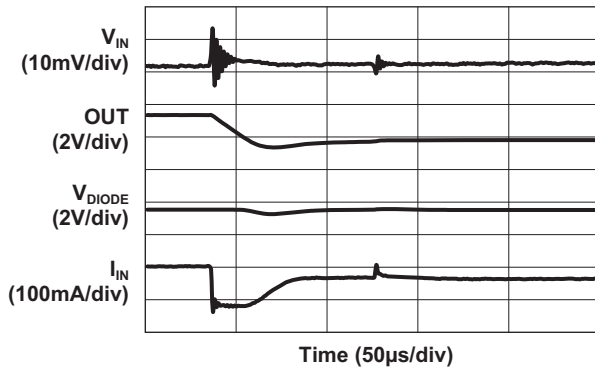

Load Switch to Charge Pump (80mA)

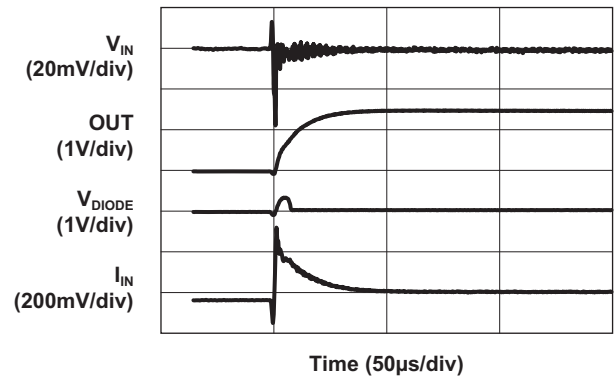

Turn-Off

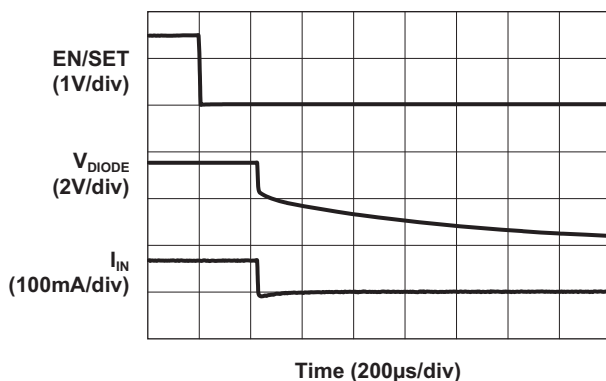

80mA Load Characteristics

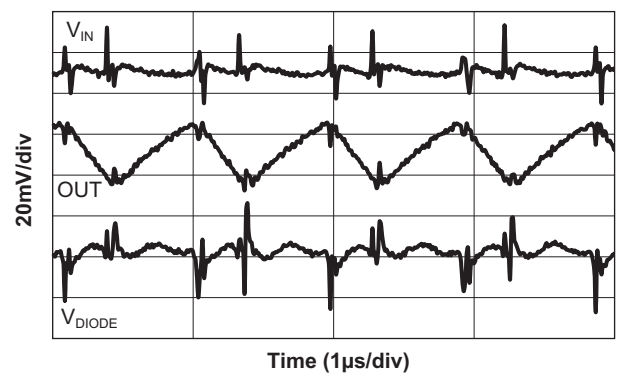

## Functional Block Diagram

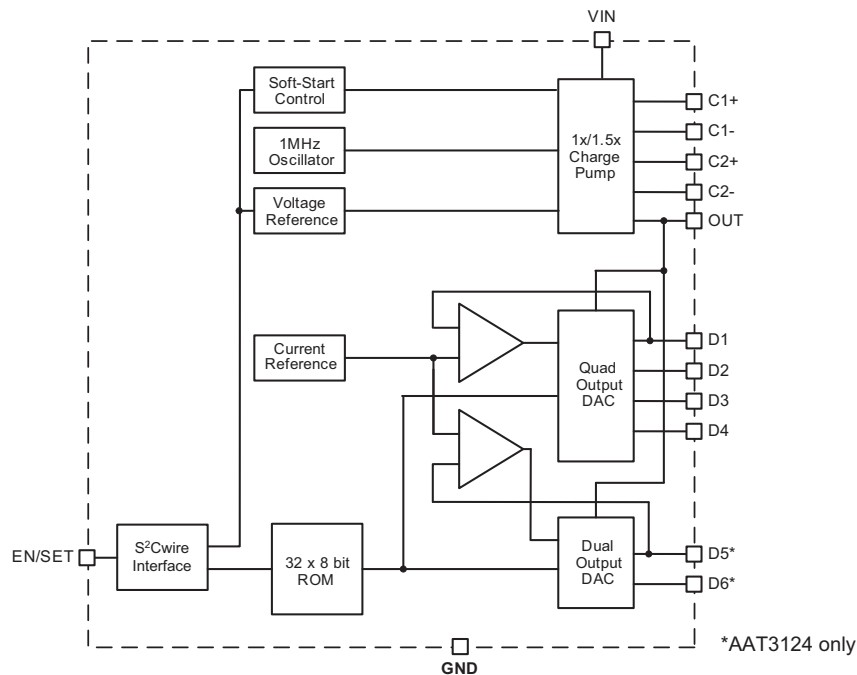

## Functional Description

The AAT3123/23A/24 is a dual mode load switch (1X) and high efficiency (1.5X) fractional charge pump device intended for white LED backlight applications. The fractional charge pump consists of a low dropout linear voltage regulator followed by a 1.5X charge pump with multiple current-source outputs. To maximize power conversion efficiency, an internal feedback control sensing circuit monitors the voltage required on the constant current source outputs. This control circuit then sets the load switch and charge pump functions based upon the input voltage level versus the output voltage level needed. This function significantly enhances overall device efficiency when the input voltage level is greater than the voltage required at the constant current source outputs. For the AAT3123/23A, the 1X load switch/1.5X charge pump mode is decided on the voltage sensed on the output D1. The AAT3124 bases the 1X load switch/1.5X charge pump mode decision on the voltage levels sensed on either the D1-D4 output group or the D5-D6 output group, whichever is greater. Switchover between the 1.5X (charge-pump) operating mode and the 1X (load switch) mode occurs automatically (as a function of input and output voltages) and does not require user intervention to maintain maximum efficiency.

The AAT3123/23A/24 requires only four external components: two 1 $\mu$ F ceramic capacitors for the charge pump flying capacitors (C<sub>1</sub> and C<sub>2</sub>), one 1 $\mu$ F ceramic input capacitor (C<sub>IN</sub>), and one 0.33 $\mu$ F to 1 $\mu$ F ceramic output capacitor (C<sub>OUT</sub>). The LDO/1.5X charge pump output is converted into four (D1 to D4) or six (D1 to D4 and D5 to D6) constant current outputs to drive four or six individual LEDs with a maximum current of 20mA each. The current source output magnitude is controlled by the EN/SET serial data S<sup>2</sup>Cwire interface. The interface records rising edges of the EN/SET pin and decodes them into 32 individual current level settings each 1dB apart (see Table 1, Current Level Settings). Code 32 is full scale, and Code 1 is full scale attenuated by 31dB. The modulo 32 interface wraps states back to State 1 after the 32nd clock.

With each EN/SET pulse, the output current increases by 1dB. To decrease the output current by 1dB, 31 EN/SET clock pulses are required. The counter can be clocked at speeds up to 1MHz, so intermediate states are not visible. The first rising edge of EN/SET enables the IC and initially sets the output LED current to -31dB, the lowest setting equal to 525 $\mu$ A. Once the final clock cycle is input for the desired brightness level, the EN/SET pin is held high to maintain the device output current at the programmed level. The device is disabled 500 $\mu$ s after the EN/SET pin transitions to a logic low state.

## Applications Information

### Constant Current Output Level Settings

The constant current source output amplitude for outputs D1 to D6 are set via the serial interface according to a logarithmic scale where each code is 1dB greater than the previous code. In this manner, LED brightness appears linear with each increasing code count. Because the outputs D1 to D6 are true independent constant current sources, the voltage observed on any single given output will be determined by the actual forward voltage ( $V_F$ ) for the LED being driven.

Since the output current of the AAT3123/23A/24 is programmable through its single-wire serial interface, no PWM (pulse width modulation) or additional control circuitry is needed to control LED brightness. This feature greatly reduces the burden on a microcontroller or system IC to manage LED or display brightness, allowing the user to “set it and forget it.” Furthermore, with its high-speed serial interface (1MHz data rate), the output current of the AAT3123/23A/24 can be changed successively to brighten or dim LEDs in smooth transitions (e.g., to fade-out) or in abrupt steps, giving the user

complete programmability and real-time control of LED brightness.

Code	$I_{OUT}$ (mA)	Code	$I_{OUT}$ (mA)
1	0.549	17	3.529
2	0.627	18	4.000
3	0.706	19	4.471
4	0.784	20	5.020
5	0.863	21	5.647
6	1.020	22	6.353
7	1.098	23	7.059
8	1.255	24	7.922
9	1.412	25	8.941
10	1.569	26	10.039
11	1.804	27	11.216
12	1.961	28	12.627
13	2.275	29	14.118
14	2.510	30	15.843
15	2.824	31	17.804
16	3.137	32	20.000

**Table 1: Constant Current Source Output Programming Levels (mA).**

### Normalized Output Current Settings

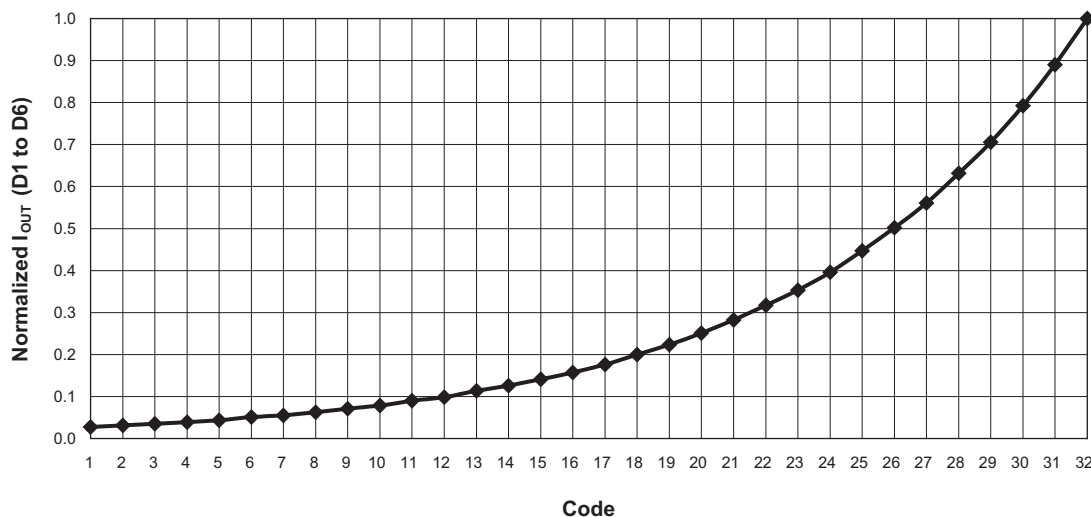





# AAT3123/23A/24

## ChargePump™ High Efficiency 1X/1.5X Fractional Charge Pump for White LED Applications

### EN/SET Serial Interface

The current source output magnitude is controlled by the EN/SET pin, using AnalogicTech's Simple Serial Control (S<sup>2</sup>Cwire) interface. The interface records rising edges of the EN/SET pin, and decodes them into 32 individual current level settings each 1dB apart. Code 32 is full scale, and Code 1 is full scale attenuated by 31dB. The modulo 32 interface wraps states back to State 1 after the 32nd clock, so 1dB of attenuation is achieved by clocking the EN/SET pin 31 times. The counter can be clocked at speeds up to 1MHz, so intermediate states are not visible. The first rising edge of EN/SET enables the IC and initially sets the output LED current to -31dB, the lowest setting equal to 525µA. Once the final clock cycle is input for the desired brightness level, the EN/SET pin is held high to maintain the device output current at the programmed level. The device is disabled 500µs after the EN/SET pin transitions to a logic low state. The EN/SET timing is designed to accommodate a wide range of data rates. After the first rising edge of EN/SET, the charge pump is enabled and reaches full capacity after the soft-start time (T<sub>SS</sub>). During the soft-start time, multiple clock pulses may be entered on the EN/SET pin to set the final output current level with a single burst of clocks. Alternatively, the EN/SET clock pulses may be entered one at a time to gradually increase LED brightness over any desired time period. A constant current is sourced as long as EN/SET remains in a logic high state. The current source outputs are switched off after EN/SET has remained in a low state for at least the t<sub>OFF</sub> timeout period.

### LED Selection

The AAT3123/23A/24 is specifically intended for driving white LEDs. However, the device design will allow the AAT3123/23A/24 to drive most types of LEDs with forward voltage specifications ranging from 2.0V to 4.3V.

LED applications may include main and sub-LCD display backlighting, camera photo-flash applications, color (RGB) LEDs, infrared (IR) diodes for remotes, and other loads benefiting from a controlled output current generated from a varying input voltage. Since the D1 to D6 output current sources are matched with negligible voltage dependence, LED brightness will be matched regardless of the specific LED forward voltage (V<sub>F</sub>) levels.

In some instances (e.g., in high luminous output applications such as photo flash), it may be necessary to drive high-V<sub>F</sub> type LEDs. The *low-dropout* current sources in the AAT3123/23A/24 make it capable of driving LEDs with forward voltages as high as 4.3V at full current from an input supply as low as 3.0V. Outputs can be paralleled to drive high-current LEDs without complication.

### Device Switching Noise Performance

The AAT3123/23A/24 operates at a fixed frequency of approximately 1MHz to control noise and limit harmonics that can interfere with the RF operation of cellular telephone handsets or other communication devices. Back-injected noise appearing on the input pin of the charge pump is 20mV peak-to-peak, typically ten times less than inductor-based DC/DC boost converter white LED backlight solutions. The AAT3123/23A/24 soft-start feature prevents noise transient effects associated with inrush currents during start-up of the charge pump circuit.

### Power Efficiency and Device Evaluation

The charge pump efficiency discussion in the following sections only accounts for efficiency of the charge pump section itself. Due to the unique circuit architecture and design of the AAT3123/23A/24, it is very difficult to measure efficiency in terms of a percent value comparing input power over output power.

### EN/SET Timing

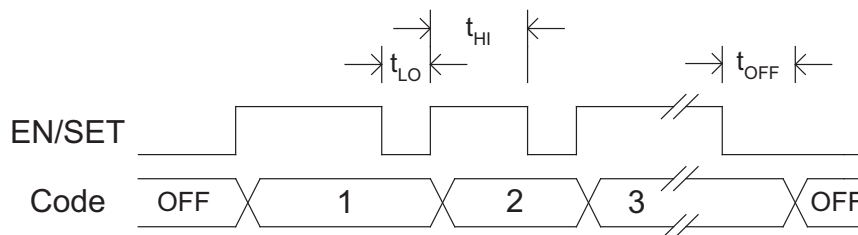

**ChargePump™ High Efficiency 1X/1.5X Fractional Charge Pump for White LED Applications**

Since the AAT3123/23A/24 outputs are pure constant current sources and typically drive individual loads, it is difficult to measure the output voltage for a given output (D1 to D6) to derive an overall output power measurement. For any given application, white LED forward voltage levels can differ, yet the output drive current will be maintained as a constant.

This makes quantifying output power a difficult task when taken in the context of comparing to other white LED driver circuit topologies. A better way to quantify total device efficiency is to observe the total input power to the device for a given LED current drive level. The best white LED driver for a given application should be based on trade-offs of size, external component count, reliability, operating range, and total energy usage...*not just % efficiency.*

The AAT3123/23A/24 efficiency may be quantified under very specific conditions and is dependent upon the input voltage versus the output voltage seen across the loads applied to outputs D1 through D4 or D6 for a given constant current setting. Depending upon the case of  $V_{IN}$  being greater than the specific voltage seen across the load on D1 (or D5 when the AAT3124 is used) the device will operate in load switch mode. If the voltage seen on the constant current source output is less than  $V_{IN}$ , then the device will operate in 1.5X charge pump mode. Each of these two modes will yield different efficiency values. Refer to the following two sections for explanations of each operational mode.

### Load Switch Mode Efficiency

The AAT3123/23A/24 load switch mode is operational at all times and functions alone to enhance device power conversion efficiency when the condition exists where  $V_{IN}$  is greater than voltage across the load connected to the constant current source outputs. When in load switch mode, the voltage conversion efficiency is defined as output power divided by input power:

$$\eta = \frac{P_{OUT}}{P_{IN}}$$

The expression to define the ideal efficiency ( $\eta$ ) can be rewritten as:

$$\eta = \frac{P_{OUT}}{P_{IN}} = \frac{V_{OUT} \times I_{OUT}}{V_{IN} \times I_{OUT}} = \frac{V_{OUT}}{V_{IN}}$$

-or-

$$\eta(\%) = 100 \left( \frac{V_{OUT}}{V_{IN}} \right)$$

### Charge Pump Section Efficiency

The AAT3123/23A/24 contains a fractional charge pump which will boost the input supply voltage in the event where  $V_{IN}$  is less than the voltage required on the constant current source outputs. The efficiency ( $\eta$ ) can be simply defined as a linear voltage regulator with an effective output voltage that is equal to one and one half times the input voltage. Efficiency ( $\eta$ ) for an ideal 1.5X charge pump can typically be expressed as the output power divided by the input power:

$$\eta = \frac{P_{OUT}}{P_{IN}}$$

In addition, with an ideal 1.5X charge pump, the output current may be expressed as 2/3 of the input current. The expression to define the ideal efficiency ( $\eta$ ) can be rewritten as:

$$\eta = \frac{P_{OUT}}{P_{IN}} = \frac{V_{OUT} \times I_{OUT}}{V_{IN} \times 1.5I_{OUT}} = \frac{V_{OUT}}{1.5V_{IN}}$$

-or-

$$\eta(\%) = 100 \left( \frac{V_{OUT}}{1.5V_{IN}} \right)$$

For a charge pump with an output of 5V and a nominal input of 3.5V, the theoretical efficiency is 95%. Due to internal switching losses and IC quiescent current consumption, the actual efficiency can be measured at 93%. These figures are in close agreement for output load conditions from 1mA to 100mA. Efficiency will decrease as load current drops below 0.05mA or when the level of  $V_{IN}$  approaches  $V_{OUT}$ . Refer to the Typical Characteristics section of this datasheet for measured plots of efficiency versus input voltage and output load current for the given charge pump output voltage options.

### Capacitor Selection

Careful selection of the four external capacitors  $C_{IN}$ ,  $C_1$ ,  $C_2$ , and  $C_{OUT}$  is important because they will affect turn-on time, output ripple, and transient performance. Optimum performance will be obtained when low equivalent series

**ChargePump™ High Efficiency 1X/1.5X Fractional Charge Pump for White LED Applications**

resistance (ESR) ceramic capacitors are used. In general, low ESR may be defined as less than 100mΩ. A value of 1μF for all four capacitors is a good starting point when choosing capacitors. If the LED current sources are only programmed for light current levels, then the capacitor size may be decreased.

### Capacitor Characteristics

Ceramic composition capacitors are highly recommended over all other types of capacitors for use with the AAT3123/23A/24. Ceramic capacitors offer many advantages over their tantalum and aluminum electrolytic counterparts. A ceramic capacitor typically has very low ESR, is lowest cost, has a smaller PCB footprint, and is non-polarized. Low ESR ceramic capacitors help to maximize charge pump transient response. Since ceramic capacitors are non-polarized, they are not prone to incorrect connection damage.

### Equivalent Series Resistance

ESR is an important characteristic to consider when selecting a capacitor. ESR is a resistance internal to a capacitor that is caused by the leads, internal connections, size or area, material composition, and ambient temperature. Capacitor ESR is typically measured in milliohms for ceramic capacitors and can range to more than several ohms for tantalum or aluminum electrolytic capacitors.

### Ceramic Capacitor Materials

Ceramic capacitors less than 0.1μF are typically made from NPO or C0G materials. NPO and C0G materials typically have tight tolerance and are stable over temperature. Large capacitor values are typically composed of X7R, X5R, Z5U, or Y5V dielectric materials. Large ceramic capacitors, typically greater than 2.2μF, are often available in low-cost Y5V and Z5U dielectrics, but capacitors greater than 1μF are typically not required for AAT3123/23A/24 applications.

Capacitor area is another contributor to ESR. Capacitors that are physically large will have a lower ESR when compared to an equivalent material smaller capacitor. These larger devices can improve circuit transient response when compared to an equal value capacitor in a smaller package size.

### Test Current/Channel Disable

Each channel of the output is equipped with test current function. A small amount of current (~2μA) is injected into each output current source to detect the presence of load (LED). Unused channels that are tied to ground or LED load fail short will be automatically disabled instead of wasting the programmed output current. The test current in the AAT3123A is higher (~150μA) to accommodate LEDs with lower impedance in failure mode.

### Thermal Protection

The AAT3123/23A/24 has a thermal protection circuit that will shut down the internal LDO and charge pump if the die temperature rises above the thermal limit, as is the case during a short-circuit of the OUT pin.

### Driving Multiple LEDs, White LED Display Module Backlights, and Individual LEDs Connected in Parallel

The AAT3123/23A/24 D1 to D6 outputs are true constant current sources capable of driving up to 20mA each over the operation input voltage range. Since these outputs are true constant current sources, they may be connected in parallel to drive a single power output. Any combination of outputs (D1 to D6) may be connected in parallel. The maximum total output current is a sum of how many current sources are parallel connected. This feature is particularly useful to power pre-manufactured display modules which are pre-wired with white LED backlights connected in a parallel circuit configuration. Any combination of outputs may be connected in parallel to drive groups of LEDs. The AAT3123 internal current source reference circuit bases feedback from current sensed on the D1 output. The AAT3124 internal current source reference circuit bases feedback from current sensed on the D1 and D5 outputs. For best operation, the only requirement for this type of application is the output D1 (and/or D5 for the AAT3124) should always be connected to the load circuit.

The AAT3124 may be used to drive multiple LEDs having differing forward voltages. Using feedback techniques, the current in D1 to D4 output current sources are referenced to the current in the LED connected to D1. In the AAT3124 (six-output version), the D5 and D6 output current sources are referenced to the current in D5, not to D1. If all six LEDs are of similar type, the diodes will be matched in current, maintaining uniform LED brightness despite variations in manufacturer, production, etc.



## ChargePump™ High Efficiency 1X/1.5X Fractional Charge Pump for White LED Applications

However, if the diodes are dramatically different in type comprising a mix of high- $V_F$  and low- $V_F$  LEDs, the AAT3124 has the capability to optimally and simultaneously drive up to four LEDs of one type and up to two LEDs of another type. Such a feature can be useful for driving different color LEDs; driving both display backlight and photo-flash LEDs; or for driving main-LCD and sub-LCD display LED backlights from a single charge pump IC.

For example, when driving independent RGB LEDs, the green and blue LEDs typically require a high  $V_F$  to operate (e.g., 3.7V), while the red LED needs a low forward voltage (e.g., 2V). By connecting the green and blue diodes to outputs D1 to D4 and the red diodes to D5 and D6, good control and uniformity in brightness are maintained despite the 2V difference in the diode forward voltages. The AAT3124 determines if the 1.5X charge pump circuit is needed based on the voltage on D1 and D5, whichever is higher. If adequate voltage is available to drive the higher voltage LED (of output D1 or D5) without the charge pump running, the IC automatically switches into step-down (1X) mode to maximize efficiency.

Similarly, if a 4V photo-flash LED array is connected to outputs D1 through D4 (with the outputs shorted together) and two 3.3V sub-LCD-display backlight LEDs are connected to outputs D5 and D6, then the AAT3124 can optimally drive each set of LEDs at the programmed current level (see application schematics). The photo flash

can be disabled by an N-channel switch connected in series with the photo-flash LED.

The AAT3123/23A/24 has only one programmed value of current and does not allow for separate on/off or brightness control of each current source output. This limitation can easily be circumvented by introducing grounded source N-channel MOSFET switches in series with the LEDs to turn any given LED (or bank of LEDs) on or off. The various LEDs can be turned on and off independently, simultaneously, or multiplexed to produce any variety of lighting effects. By reprogramming the current source (via the serial interface) between switching transitions, the brightness of individual LEDs or banks of LEDs can also be controlled.

### Charge Pump Compatibility

The four-output AAT3123 is pin compatible with the AAT3113 in both QFN and TSOPJW packages. The six-output AAT3124 is pin compatible with the AAT3114 in the QFN package. Compared to the AAT3113/14, the AAT3123/23A/24 offers an improved overall efficiency, wider operating range, and the ability to drive high- $V_F$  LEDs (up to 4.3V) at full current from a 3V input condition. The AAT3123/23A/24 is well suited for battery-powered applications using single-cell lithium-ion (li-ion) batteries (4.2V to 2.8V), lithium-polymer batteries, and 3-series connected dry cells (3.6V).

## Additional Application Circuits

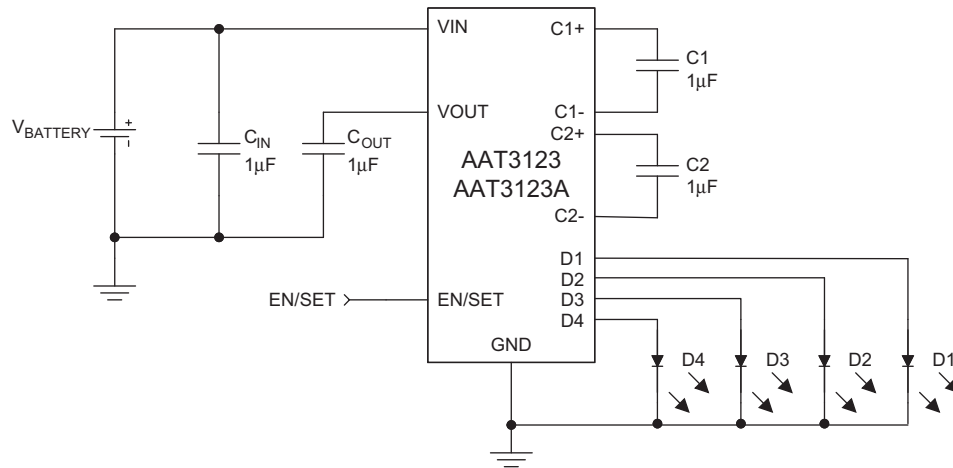

Typical AAT3123/23A Application Circuit.

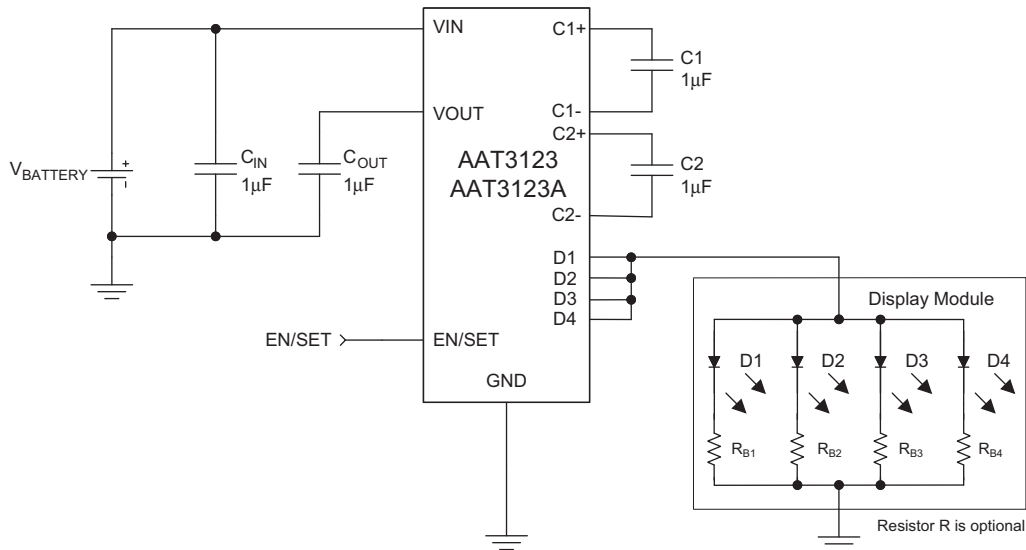

AAT3123/23A Driving a Display Module with Four Paralleled White LEDs.

## Additional Application Circuits (continued)

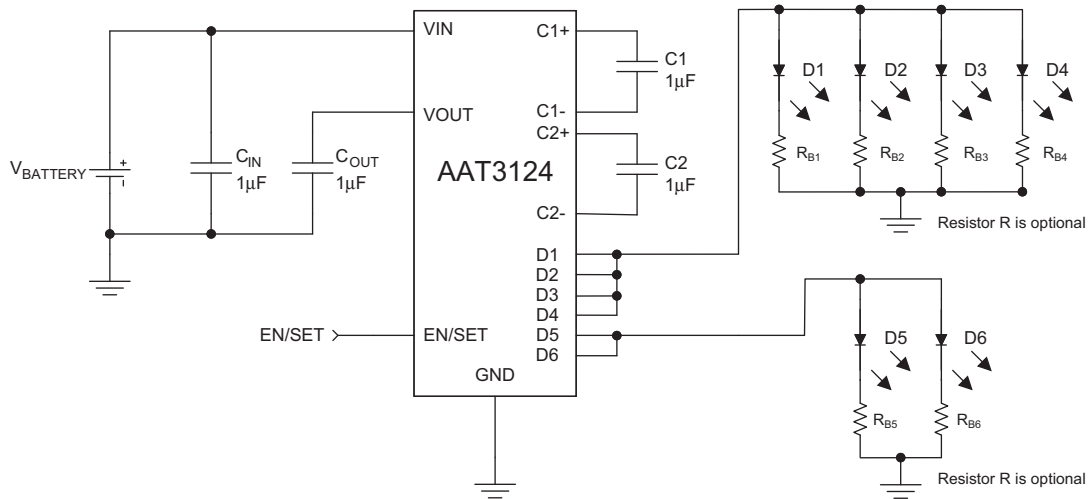

**AAT3124 Driving Two Groups of Paralleled White LEDs (e.g., main and sub-LCD backlights).**

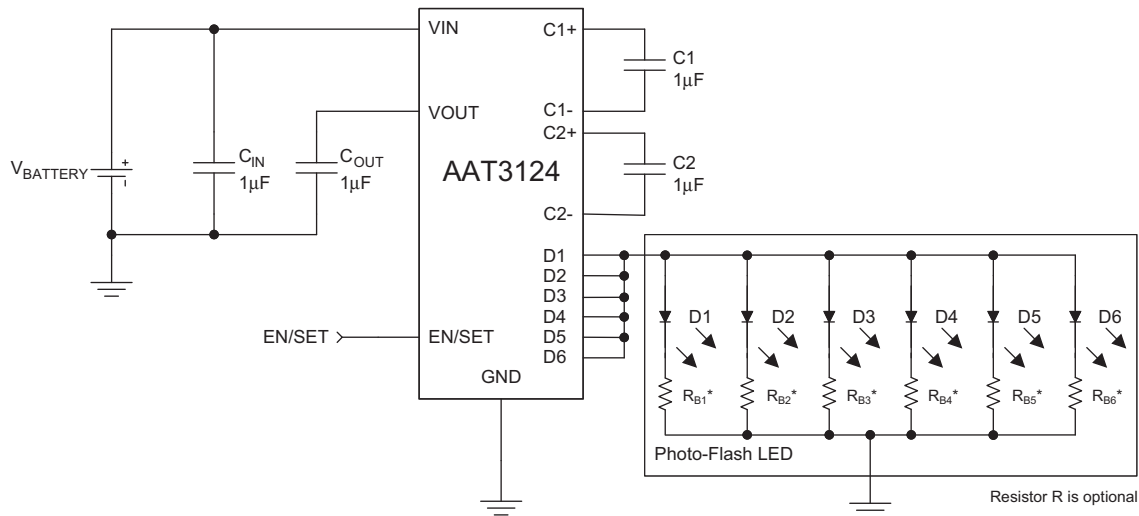

\*In some applications, white LED forward voltages ( $V_f$ ) can vary significantly. Ballast resistors between the LED cathodes and ground are recommended for balancing the forward voltage differences. The ballast resistor value may be approximated by the following equation:

$$R_B = \frac{V_{SOURCE} - V_f}{I_f}$$

**AAT3124 Driving a High-Current Photo-Flash LED.**

## Additional Application Circuits (continued)

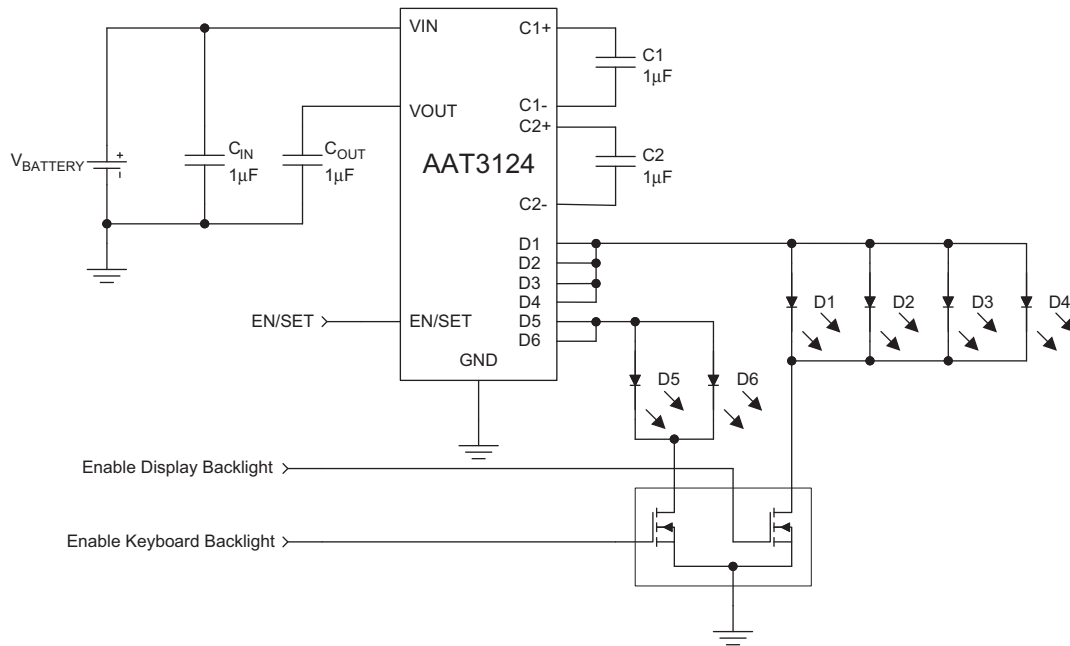

**AAT3124 Driving Two Groups of Paralleled White LEDs (with series N-channel switch).**

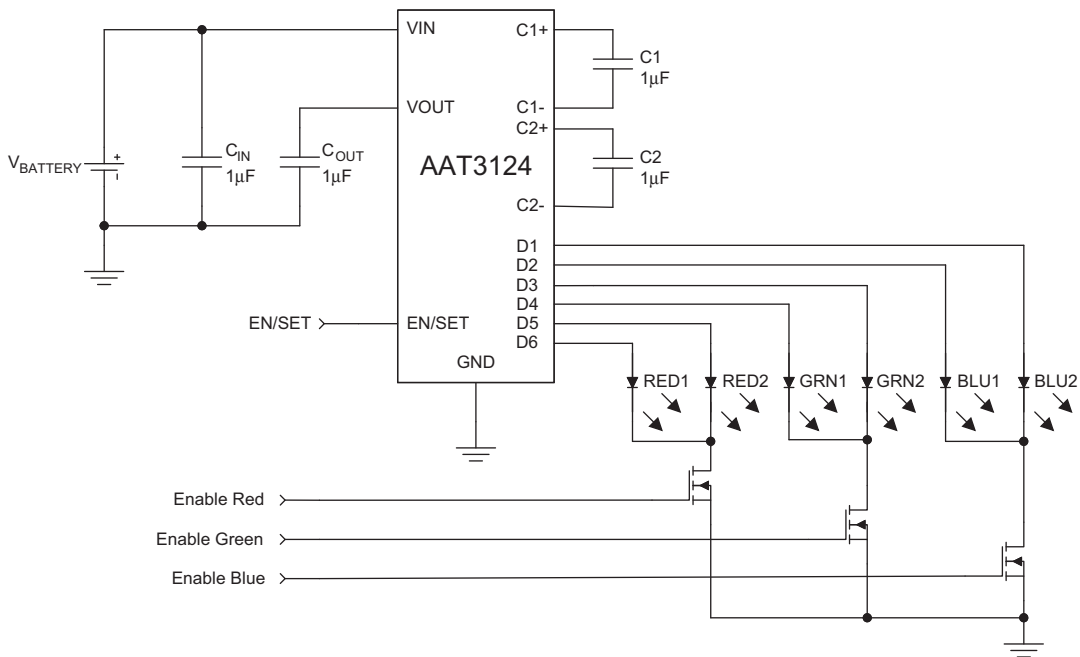

**AAT3124 Separately Driving RGB Color LEDs.**

**Additional Application Circuits (continued)**

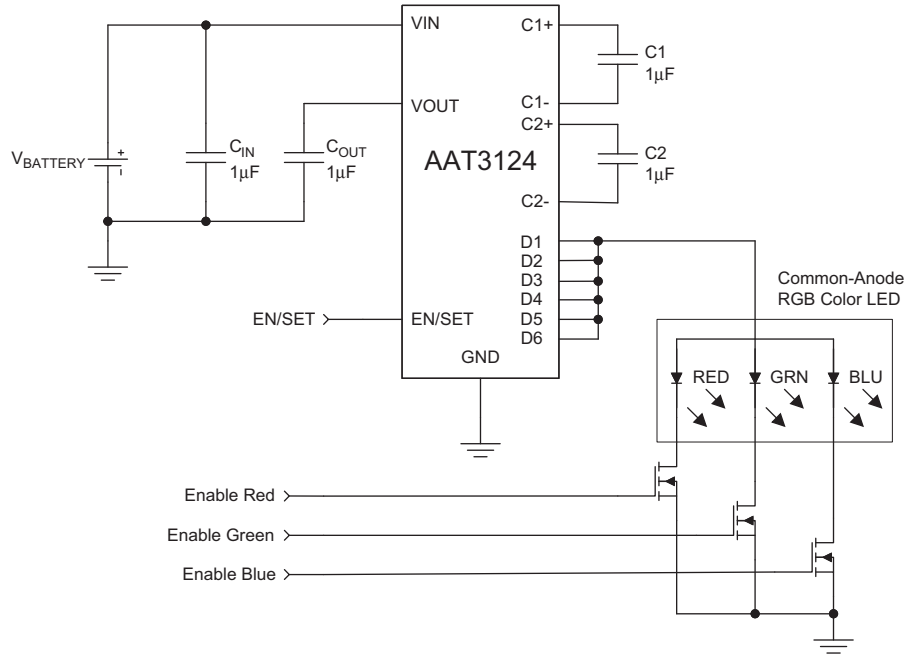

**AAT3124 Driving Common-Anode RGB Color LED.**



## Ordering Information

Package	Marking <sup>1</sup>	Part Number (Tape and Reel) <sup>2</sup>	Description
TSOPJW-12	IRXY	<b>AAT3123ITP-20-T1</b>	4-Channel Output
TSOPJW-12	OIXY	<b>AAT3123AITP-20-T1</b>	4-Channel Output with Increased Start-Up Current (see "Test Current/Channel Disable" section on page 11)
QFN44-16	ISXY	<b>AAT3124ISN-20-T1</b>	6-Channel Output
TSOPJW-14	4BXY	<b>AAT3124ITO-20-T1</b>	6-Channel Output



All AnalogicTech products are offered in Pb-free packaging. The term "Pb-free" means semiconductor products that are in compliance with current RoHS standards, including the requirement that lead not exceed 0.1% by weight in homogeneous materials. For more information, please visit our website at <http://www.analogictech.com/about/quality.aspx>.

## Package Information

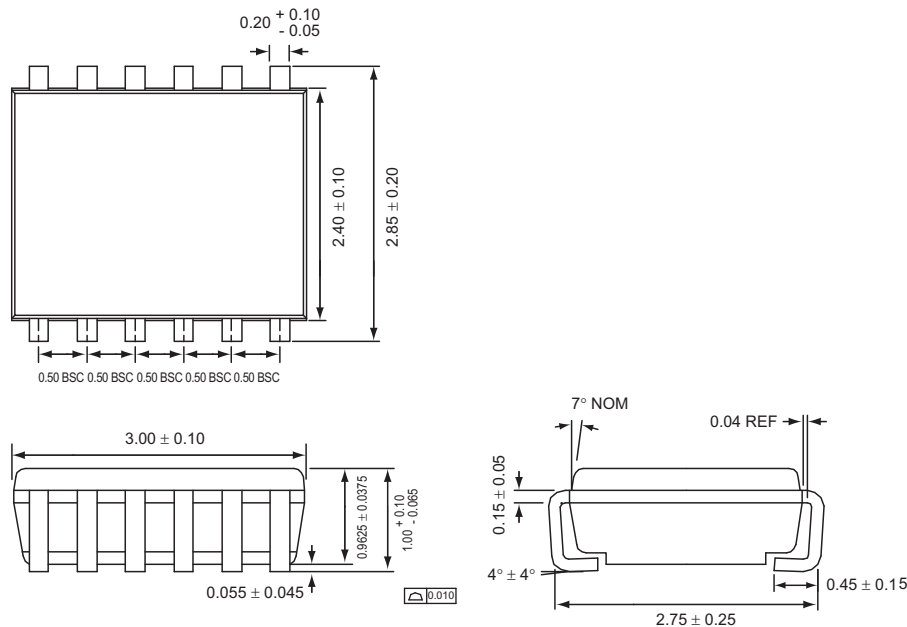
**TSOPJW-12**

All dimensions in millimeters.

1. XYY = assembly and date code.  
2. Sample stock is generally held on all part numbers listed in **BOLD**.

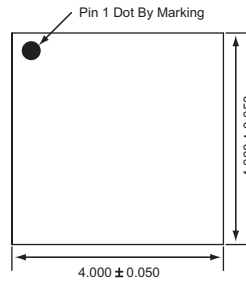
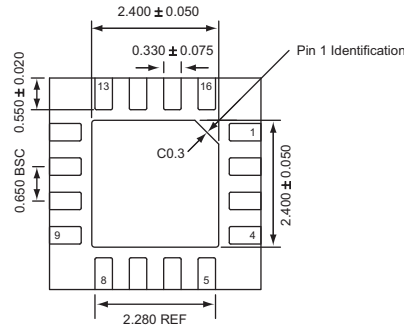
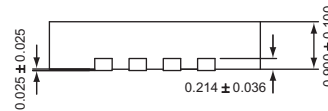
**QFN44-16<sup>1</sup>**

**Top View**

**Bottom View**

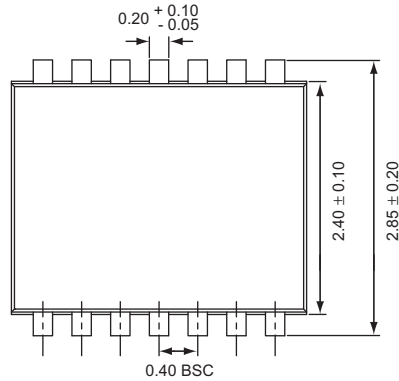
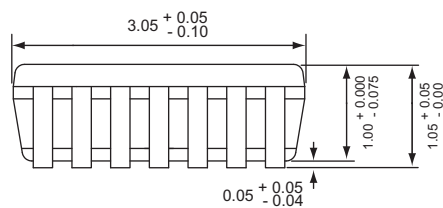
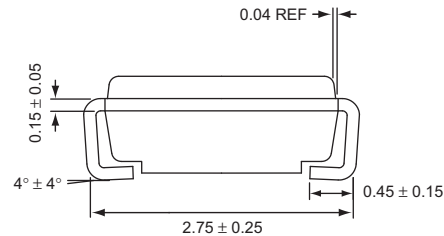
**Side View**

All dimensions in millimeters.

1. The leadless package family, which includes QFN, TQFN, DFN, TDFN and STD FN, has exposed copper (unplated) at the end of the lead terminals due to the manufacturing process. A solder fillet at the exposed copper edge cannot be guaranteed and is not required to ensure a proper bottom solder connection.

**TSOPJW-14**

**Top View**

**Side View**

**End View**

All dimensions in millimeters.

**Advanced Analogic Technologies, Inc.**  
 3230 Scott Boulevard, Santa Clara, CA 95054  
 Phone (408) 737-4600  
 Fax (408) 737-4611