

# 10 Base-T Transceiver Module (Preliminary)

## EPE6291S-3

- Robust design allows for toughest soldering processes •
- Provided with superior common mode attenuation •
- Complies with or exceeds IEEE 802.3, 10 Base-T Requirements •

### Electrical Parameters @ 25° C

Chip Side Inductance ( $\mu$ H Min.)	Insertion Loss (dB Max.)		Return Loss (dB Min.)		Attenuation (dB Min.)						Common Mode Rejection (dB Min.)				Crosstalk (dB Min.)			
	@ 100 KHz, 0.1 Vrms	1-10 MHz	5-10 MHz		@ 25 MHz	@ 30 MHz	@ 40 MHz	@ 50 MHz	@ 100 MHz	@ 200 MHz	@ 1-10 MHz							
	Xmit	Rcv	Xmit	Rcv	Xmit	Rcv	Xmit	Rcv	Xmit	Rcv	Xmit	Rcv	Xmit	Rcv	Xmit	Rcv		
200	-1	-1	-25	-25	-1	-1	-1	-1	-1	-1	-40	-35	-35	-25	-35	-20	-35	-35

- Isolation : meets or exceeds IEEE 802.3 Requirements • Impedance @ cable side : 100 •

### Schematic

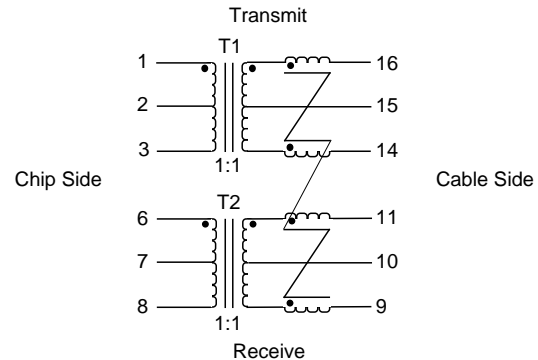

### Package

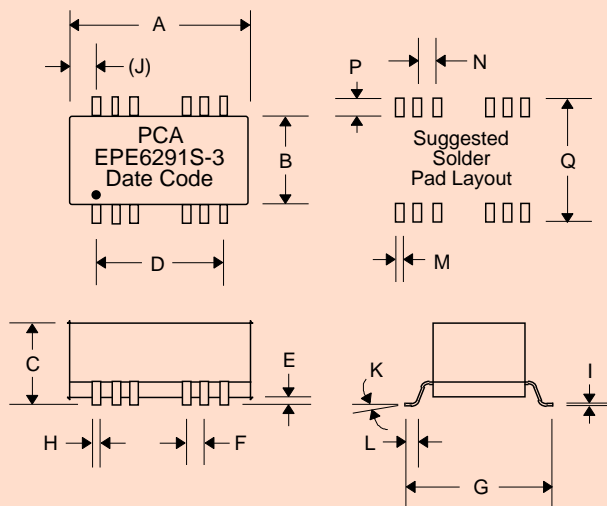

### Dimensions

Dim.	(Inches)			(millimeters)		
	Min.	Max.	Nom.	Min.	Max.	Nom.
A	.530	.550		13.46	13.97	
B	.260	.280		6.60	7.11	
C	.230	.250		5.84	6.35	
D	.350	Typ.		8.89	Typ.	
E	.005	.015		.127	.381	
F	.050	Typ.		1.27	Typ.	
G	.370	.390		9.40	9.91	
H	.016	.022		.406	.559	
I	.010	Typ.		.254	Typ.	
(J)	.095	Typ.		2.41	Typ.	
K	0°	8°		0°	8°	
L	.035	.055		.890	1.40	
M			.030			.762
N			.050			1.27
P			.055			1.40
Q			.420			10.67

Checked By \_\_\_\_\_ Date \_\_\_\_\_ Approved By \_\_\_\_\_ Date \_\_\_\_\_ Approved By \_\_\_\_\_ Date \_\_\_\_\_