

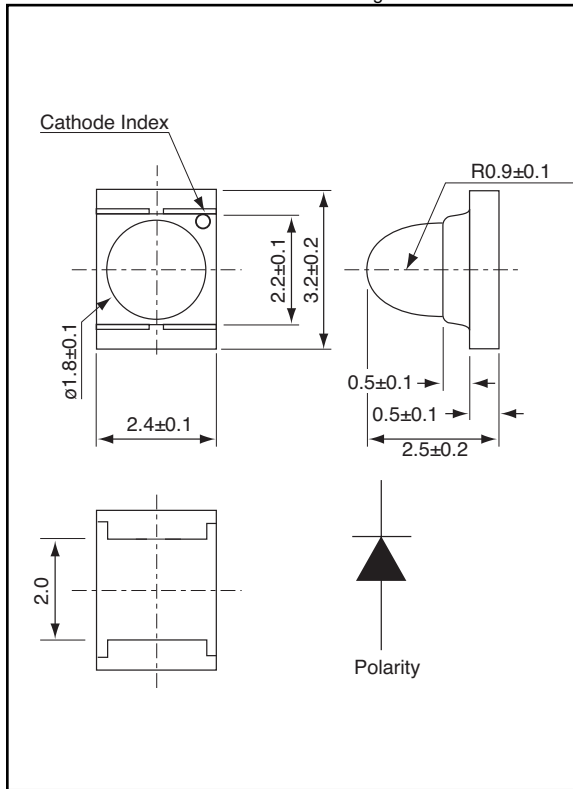

Weight: 2.0 Unit: mm



Product specifications contained herein may be changed without prior notice. It is therefore advisable to contact Purdy Electronics before proceeding with the design of equipment incorporating this product.

## AND5BA

### GaN Ultra Bright Blue Light Emission Surface Mount Package

#### Features

- Small package size with dome lens
  - 3.2 (l) x 2.4 (w) x 2.6 (h) size
  - Suitable for REFLOW soldering
  - Recommended Forward Current: 10 mA
- RoHS Compliant

#### Maximum Ratings ( $T_a = 25^\circ\text{C}$ )

Characteristics	Symbol	Rating	Unit
Forward Current	$I_F$	30	mA
Reverse Voltage	$V_R$	4	V
Power Dissipation	$P_D$	100	mW
Operating Temperature Range	$T_{Opr}$	-30 to 85	$^\circ\text{C}$
Storage Temperature Range	$T_{Stg}$	-30 to 90	$^\circ\text{C}$

#### Electro-Optical Characteristics ( $T_a = 25^\circ\text{C}$ )

Characteristics	Symbol	Test Condition	Minimum	Typical	Maximum	Unit
Forward Voltage	$V_F$	$I_F = 20 \text{ mA}$	–	3.8	4.5	V
Reverse Current	$I_R$	$V_R = 4 \text{ V}$	–	–	100	$\mu\text{A}$
Luminous Intensity	$I_V$	$I_F = 20 \text{ mA}$	90	112	–	mcd
Peak Emission Wavelength	$\lambda_P$	$I_F = 20 \text{ mA}$	–	430	–	nm
Spectral Line Half Width	$\Delta\lambda$	$I_F = 20 \text{ mA}$	–	65	–	nm
Dominant Wavelength	$\lambda_d$	$I_F = 20 \text{ mA}$	–	450	–	nm
Full Viewing Angle	$\theta$	$I_V = 1/2 \text{ Peak}$	–	30	–	degree

#### Precaution

Please be careful of the following:

1. Manual soldering: maximum temperature of iron tip:  $260^\circ\text{C}$  max.  
Soldering time: within 5 sec. per solder-land  
Soldering portion of lead: up to 1.6 mm from the body of the device
2. Reflow solder: recommended condition is as follows:

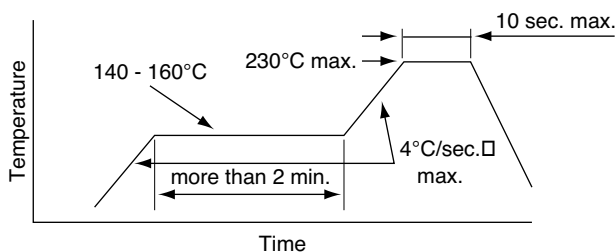

3. Absolute secure counter measures against static electricity and surge should be taken when handling these products. It is recommended to use wrist band or antistatic gloves when handling these LEDs.

The following soldering patterns are recommended for reflow soldering

