

Product Features

- GaAs Power Doubler
- Extremely Low Distortion
- Guaranteed Broadband Power Gain
- Heat Sink 99.9% Copper, & Gold Plated
- Excellent Thermal Conductivity
- Single Supply Voltage @ 24V
- Low DC Power Consumption
- Optimal Reliability

Application

- CATV Trunk Amplifier
- Optical Drive Amplifier



Package Type: SOT-115J

Description

Hybrid Power Doubler amplifier for CATV Systems up to 1000MHz in frequency. This hybrid amplifier module operates with a single voltage supply of 24V(DC), and use GaAs MMIC technology.

Quick Reference Data

SYMBOL	PARAMETER	CONDITIONS	MIN.	MAX.	UNIT
G_p	Power Gain	F = 45 MHz	18.5	19.5	dB
		F = 1000 MHz	19.5	22.0	dB
I_{tot}	Total Current Consumption (DC)	$V_{cc} = 24V$	-	420	mA

Limiting Values

SYMBOL	PARAMETER	MIN.	MAX.	UNIT
V_i	RF Input Voltage (Single Tone)	-	+70	dBmV
V	DC Supply Over Voltage (5 minutes)		28	V
T_{stg}	Storage Temperature	-40	+100	°C
T_{mb}	Operating Mounting Base Temperature	-20	+100	°C

FUNCTIONAL DIAGRAM

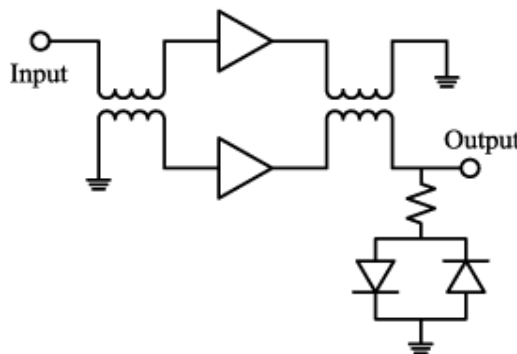

CHARACTERISTICS

Bandwidth 45 to 1000MHz; $V_{CC} = 24V$; $T_{case} = 25^{\circ}C$; $Z_S = Z_L = 75\Omega$

SYMBOL	PARAMETER	CONDITIONS	MIN	TYP	MAX	UNIT
G_p	Power Gain	f = 45 MHz	20.0	-	20.5	dB
		f = 1000 MHz	20.5	-	22.0	dB
SL	Slope Cable Equivalent	f = 45 to 1000 MHz	0.5	1.5	-	dB
FL	Flatness of Frequency Response	f = 45 to 1000 MHz	-	-	0.6	dB
S_{11}	Input Return Loss	f = 45 to 80 MHz	20.0	-	-	dB
		f = 80 to 160 MHz	19.0	-	-	dB
		f = 160 to 320 MHz	18.0	-	-	dB
		f = 320 to 640 MHz	17.0	-	-	dB
		f = 640 to 1000 MHz	16.0	-	-	dB
S_{22}	Output Return Loss	f = 45 to 80 MHz	20.0	-	-	dB
		f = 80 to 160 MHz	19.0	-	-	dB
		f = 160 to 320 MHz	18.0	-	-	dB
		f = 320 to 640 MHz	17.0	-	-	dB
		f = 640 to 1000 MHz	16.0	-	-	dB
F	Noise Figure	f = 45 MHz	-	5.0	6.0	dB
		f = 1000 MHz	-	7.5	8.0	dB
I_{tot}	Total Current Consumption (DC)		380	400	420	mA

DISTORTION

Bandwidth 45 to 550MHz; $V_{CC} = 24V$; $T_{case} = 25^{\circ}C$; $Z_S = Z_L = 75\Omega$

SYMBOL	PARAMETER	CONDITIONS	MIN	TYP	MAX	UNIT
CTB	Composite Triple Beat	79ch. 7dB tilted; $V_o = +52dBmV$	-	-65	-63	dBc
XMOD	Cross Modulation	79ch. 7dB tilted; $V_o = +52dBmV$	-	-68	-66	dBc
CSO	Composite Second Order Distortion	79ch. 7dB tilted; $V_o = +52dBmV$	-	-63	-61	dBc

Notes;

79 Channels, NTSC frequency raster: 55.25MHz to 547.25MHz, +45dBmV to +52dBmV tilted output level.

CTB, XMOD, CSO definitions follow NCTA definition.

ESD PROTECTION

Gallium Arsenide Integrated Circuits are sensitive to electrostatic discharge (ESD) and can be damaged by static electricity. Proper ESD control techniques should be used when handling these devices. Some of the precautions recommended are;

- Person at a workbench should be earthed via a wrist strap and a resistor.
- All mains-powered equipment should be connected to the mains via an earth-leakage switch.
- Equipment cases should be grounded.
- Relative humidity should be maintained between 40% and 50%.
- An ionizer is recommended.
- Keep static materials, such as plastic envelopes and plastic trays etc. away from the workbench.

NOTES FOR CORRECT USE

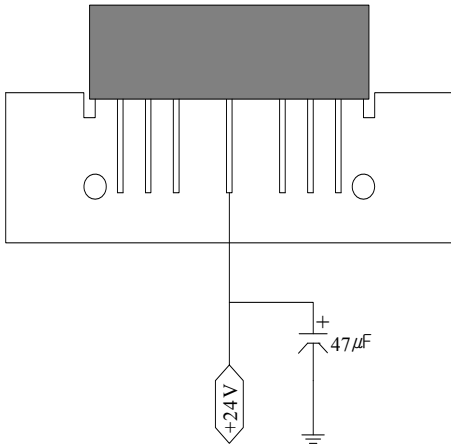

1. On the power input port (Pin#5), 47µF/35V capacitor GND is recommended.
2. The heat sink of CATV Hybrids is to be mounted in direct contact with the metal case of the equipment. Heat conducting grease should be applied to the module/equipment interface and the unit tightly secured.
3. Put the power off before adjusting in/output matching of the system.
4. The unit must have a common ground with the equipment and the analyzer.
5. Pay close attention to the input voltage not to over power the hybrid.
6. The space between bottom of socket and the tip of the lead is recommended to have space of 2mm+ to protect the pin
7. Do not open the plastic cover to change the matching inside the hybrid. Once opened, RFHIC will not be responsible for the hybrid.

Package Dimensions (Type: SOT-115J)

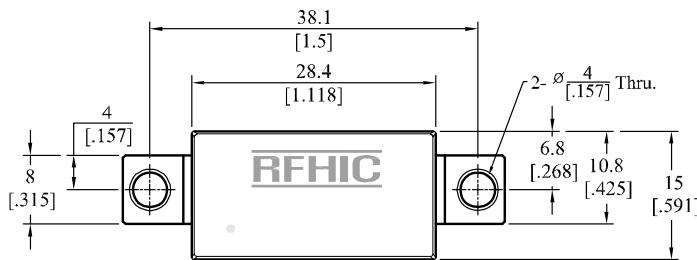

Pin No.	Function
1	RF Input
2, 3, 7, 8	Ground
5	Vcc
9	RF Output

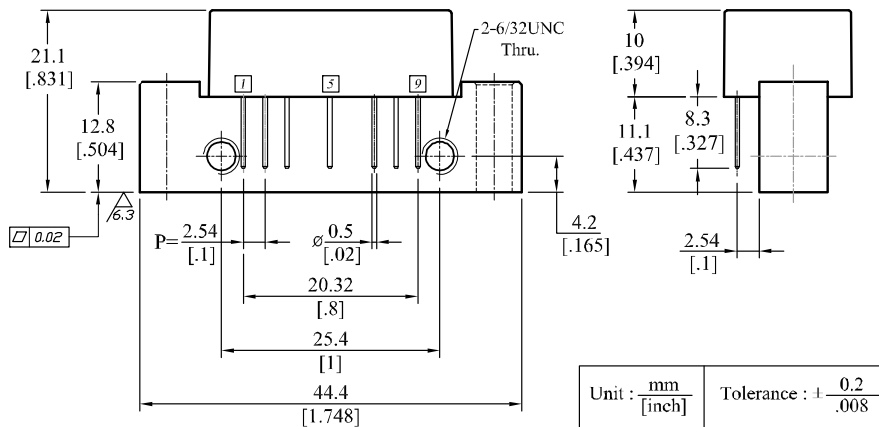

Unit : $\frac{\text{mm}}{\text{[inch]}}$	Tolerance : $\pm \frac{0.2}{.008}$
--	------------------------------------

RFHIC Corporation (RFHIC) reserves the right to make changes to any products herein or to discontinue any product at any time without notice. RFHIC do not assume any liability for the suitability of its products for any particular purpose, and disclaims any and all liability, including without limitation consequential or incidental damages. The product specifications herein expressed have been carefully checked and are assumed to be reliable. However, RFHIC disclaims liability for inaccuracies and strongly recommends buyers to verify that the information they are using is current before placing purchase orders. RFHIC products are not intended for use in life support equipment or application where malfunction of the product can be expected to result in personal injury or death. Buyer uses or sells such products for any such unintended or unauthorized application, buyer shall indemnify, protect and hold RFHIC and its directors, officers, stockholders, employees, representatives and distributors harmless against any and all claims arising out of such use. RFHIC's liability under or arising out of damages, claims of whatsoever kind and nature which RFHIC products could cause shall be limited in amount to the net purchase price of the products sold to buyer by RFHIC.