

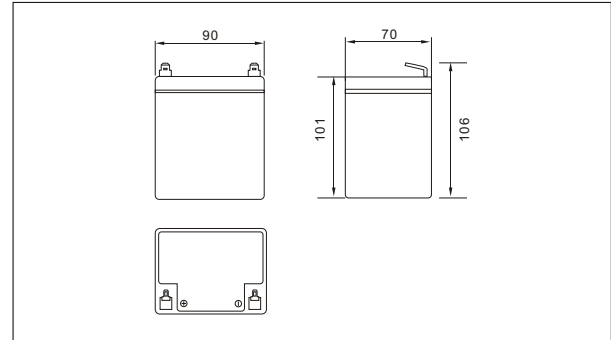

SW1245(12V4.5AH)



Outer dimensions (mm)



Specifications

Nominal Voltage	12V	
Rated capacity (20 hour rate)	4.5Ah	
Dimensions	Total Height	106mm (4.17 inches)
	Height	101mm (3.98 inches)
	Length	90mm (3.54 inches)
	Width	70mm (2.76 inches)
Weight Approx	1.56Kg (3.43lbs)	

Terminal Type (mm)

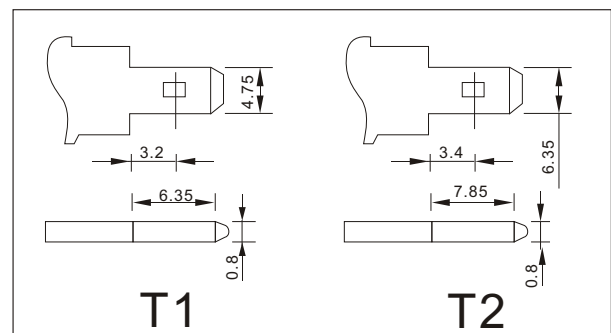

Characteristics

Capacity 25°C(77°F)	20 hour rate(0.225A)	4.50 AH
	10 hour rate(0.41 A)	4.10 AH
	5 hour rate(0.77 A)	3.85 AH
	1 hour rate(2.70 A)	2.70 AH
	1.5 hour discharge to 10.5V	1.8 A
Internal Resistance	Full charged Battery at 25°C(77°F)	30 m Ω
Capacity affected by Temperature (20hour rate)	40°C(104°F)	102%
	25°C(77°F)	100%
	0°C(32°F)	85%
	-15°C(5°F)	65%
Self-Discharge at 25°C(77°F)	Capacity after 3 month storage	91%
	Capacity after 6 month storage	82%
	Capacity after 12 month storage	64%
Terminal	T1 or T2	
Charge (constant Voltage)	Cycle	Initial Charging Current less than 1.80A Voltage 14.40-14.70V
	Float	Voltage 13.50-13.80V

Discharge Curves 25°C(77°F)

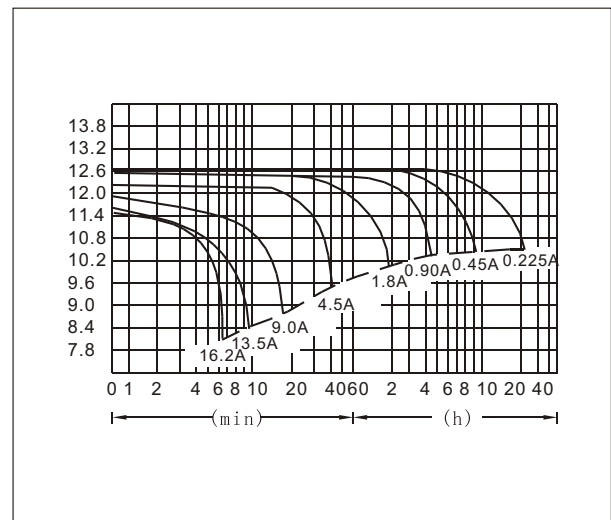

Constant Current(Amp) and Constant Power(Watt) Discharge Table at 25°C(77°F)

Time		5min	10min	15min	30min	1h	2h	3h	4h	5h	8h	10h	20h
9.60V	A	16.2	10.6	7.9	5.2	2.7	1.58	1.16	0.93	0.79	0.52	0.43	0.23
	W	168	114	84	56	29	17.3	12.9	10.5	9.0	6.0	4.9	2.7
10.20V	A	14.9	10.2	7.2	4.9	2.5	1.51	1.13	0.90	0.77	0.51	0.42	0.23
	W	160	114	81	55	29	17.4	13.0	10.5	9.0	6.0	4.9	2.7
10.50V	A	13.5	9.5	6.8	4.8	2.5	1.48	1.11	0.86	0.77	0.51	0.41	0.23
	W	149	108	77	55	28	17.2	12.9	10.0	9.0	6.0	4.9	2.7
10.80V	A	13.0	9.1	6.3	4.6	2.4	1.44	1.09	0.84	0.73	0.49	0.40	0.22
	W	146	105	73	54	28	16.9	12.8	9.9	8.6	5.9	4.8	2.6
11.10V	A	12.0	8.6	5.9	4.5	2.3	1.41	1.03	0.82	0.70	0.48	0.39	0.21
	W	136	99	68	53	27	16.6	12.2	9.8	8.3	5.8	4.8	2.6