

Voltage-Controlled Attenuator Module 5 to 2000 MHz

Rev. V4

Features

- AVAILABLE IN SURFACE MOUNT
- LOW VSWR: < 1.8:1 (TYP.)
- LOW INSERTION LOSS: 2.0 dB TO 1000 MHz (TYP.)
- LOW DISTORTION: -25 dBc (TYP.) AT $V_{control} = +15 V$

Description

The G1 attenuator is a discrete hybrid design, which uses thin film manufacturing processes for accurate performance and high reliability.

This design uses three pin diodes to provide a non linear attenuation response across a broadband frequency range. Both TO-8 and Surface Mount packages are hermetically sealed, and MIL-STD-883 environmental screening is available.

Ordering Information

Part Number	Package
G1	TO-8
SMG1	Surface Mount
CG1 **	SMA Connectorized

** The connectorized version is not RoHs compliant.

Product Image

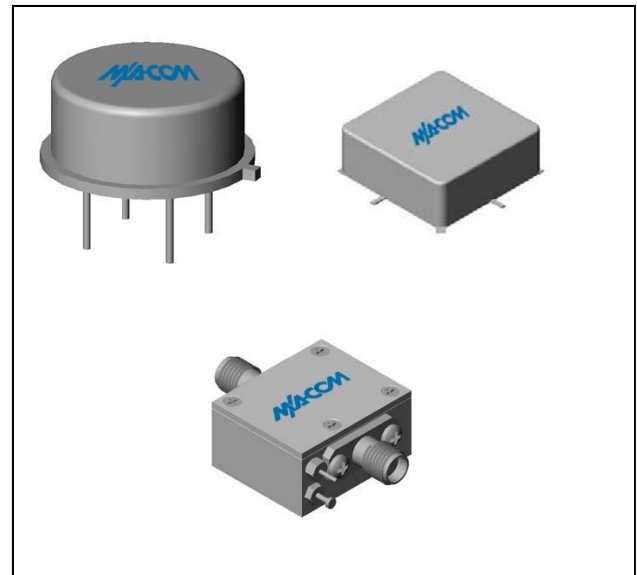

Electrical Specifications: $Z_0 = 50\Omega$, $V_{CC} = +15 V_{DC}$

Parameter	Units	Typical	Guaranteed	
		25°C	0° to 50°C	-54° to +85°C*
Frequency	MHz	5-2200	5-2000	5-2000
Maximum Attenuation Available (min)	5-500 MHz	36	31	30
	500-1000 MHz	30	25	24
	1000-2000 MHz	23	18	17
Insertion Loss ($V_{ctrl} = +15 V$) (max)	5-1000 MHz	2.0	2.5	2.8
	1000-2000 MHz	2.5	3.0	3.3
VSWR (worst case in attenuation range)	dB	<1.8:1	2.2:1	2.3:1
Flatness Over Frequency (max) (Attenuation = min to 15 dB, 5-1000 MHz)		+/-0.5	+/-1.0	+/-1.2
Switching Speed (max.)	10% - 90%	60	120	140
	0% - 100%	75	125	140
Bias Voltage	Volts	+15	+15	+15
Bias Current	mA	10	15	15
Control Voltage	Volts	0 to +15	0 to +15	0 to +15
Control Current (max)	mA	4	7	7

*Over temperature performance limits for part number CG1, guaranteed from 0°C to +50°C only.

ADVANCED: Data Sheets contain information regarding a product M/A-COM Technology Solutions is considering for development. Performance is based on target specifications, simulated results, and/or prototype measurements. Commitment to develop is not guaranteed.

PRELIMINARY: Data Sheets contain information regarding a product M/A-COM Technology Solutions has under development. Performance is based on engineering tests. Specifications are typical. Mechanical outline has been fixed. Engineering samples and/or test data may be available. Commitment to produce in volume is not guaranteed.

• **North America** Tel: 800.366.2266 • **Europe** Tel: +353.21.244.6400
 • **India** Tel: +91.80.4155721 • **China** Tel: +86.21.2407.1588
 Visit www.macomtech.com for additional data sheets and product information.

M/A-COM Technology Solutions Inc. and its affiliates reserve the right to make changes to the product(s) or information contained herein without notice.

Typical Performance Curves at +25°C

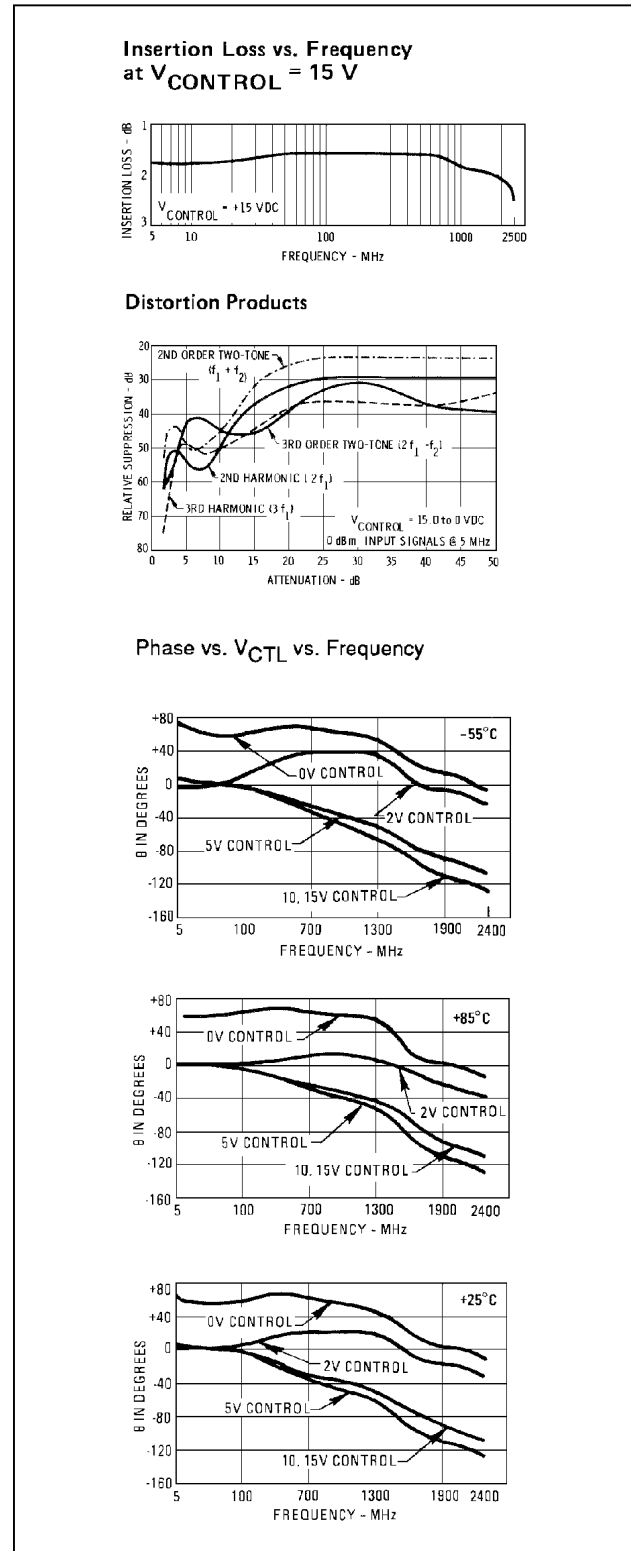
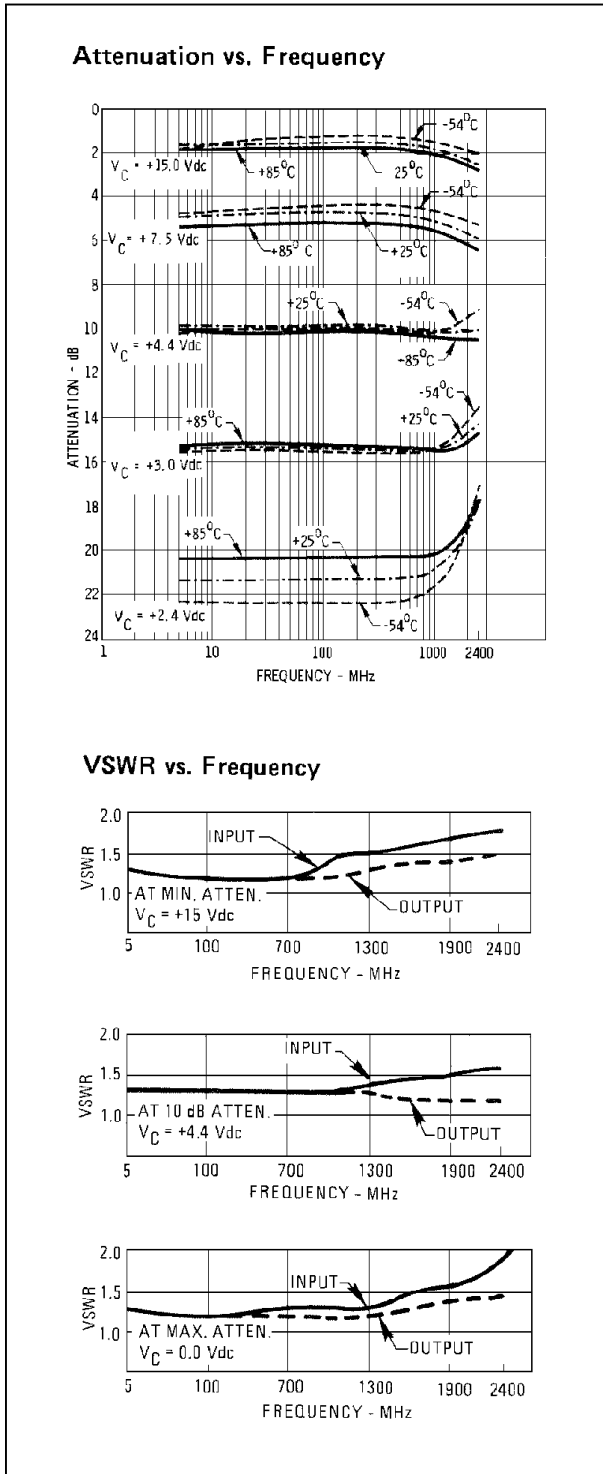

Voltage-Controlled Attenuator Module 5 to 2000 MHz

Rev. V4

Typical Performance Curves at +25°C

Attenuation vs. Control Voltage

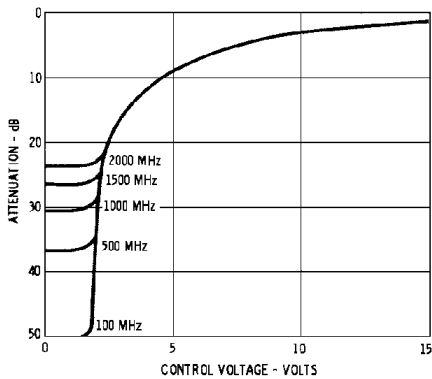

Attenuation vs. V_{CTL} vs. Frequency

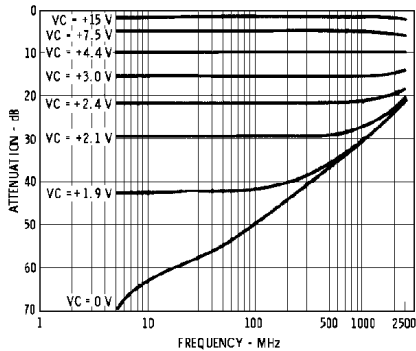

Absolute Maximum Ratings

Parameter	Absolute Maximum
Storage Temperature	-62°C to +125°C
Case Temperature	125°C
DC Voltage	+18 V
Continuous Input Power	+20 dBm
Short Term Input power (1 minute max.)	200 mW
Peak Power (3 μ sec max.)	1 W
"S" Series Burn-In Temperature (case)	125°C

Outline Drawing: TO-8 *

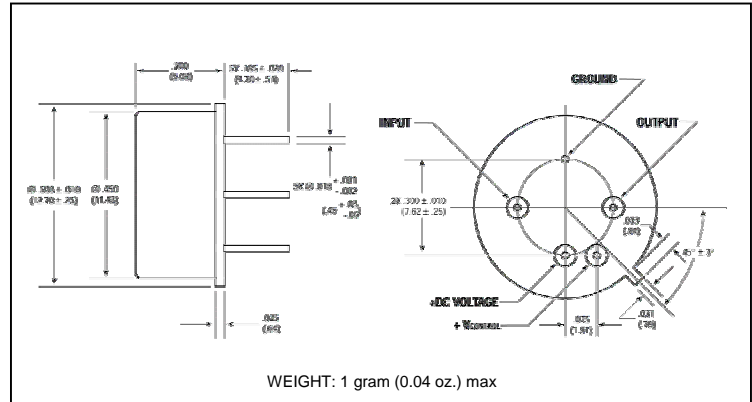

Outline Drawing: Surface Mount *

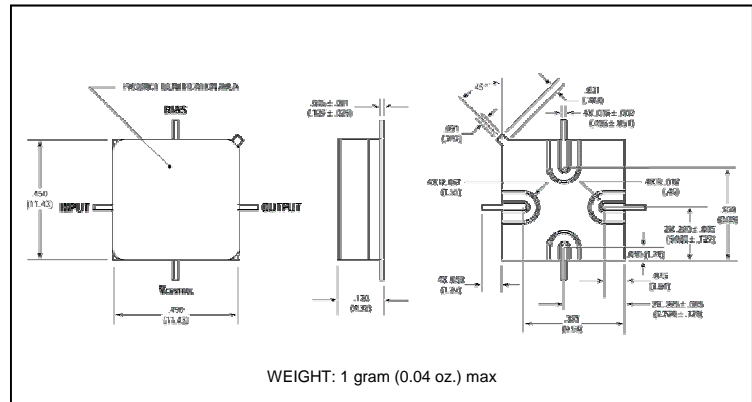

Outline Drawing: SMA Connectorized *

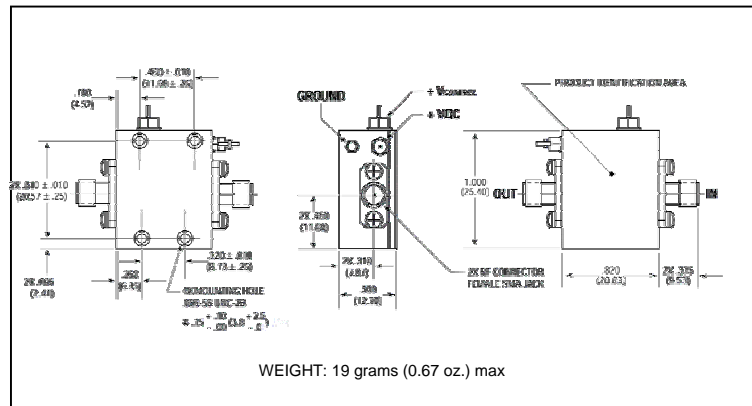

* Dimensions are inches (millimeters) ± 0.015 (0.38) unless otherwise specified.