

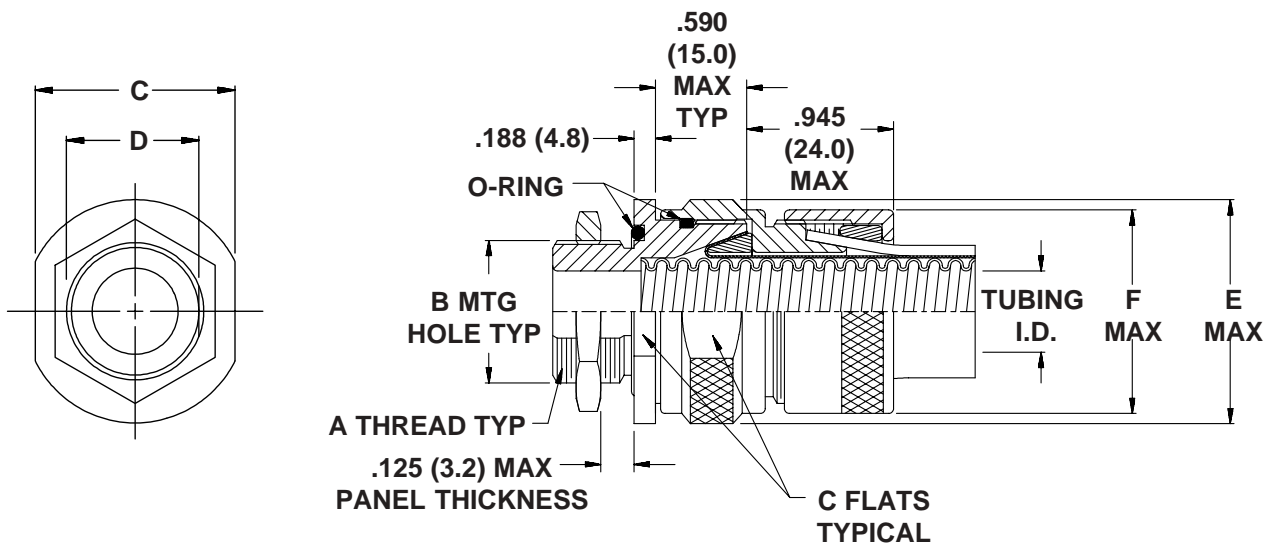

**712-389 - Types B, C, D, E, F & G  
User-Installable Bulkhead Fitting  
for Series 74 Helical Convuluted Tubing**

**TYPES  
B, C, D, E,  
F, & G  
BULKHEAD**

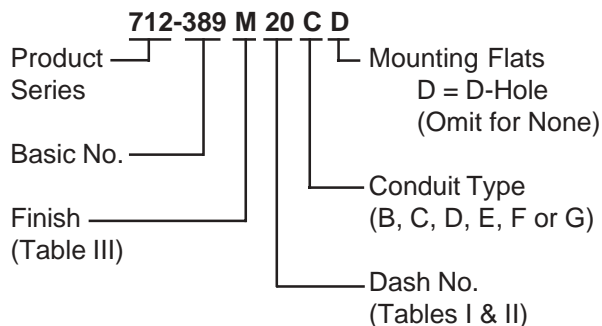

**TYPES C & F  
ENVIRONMENTAL**

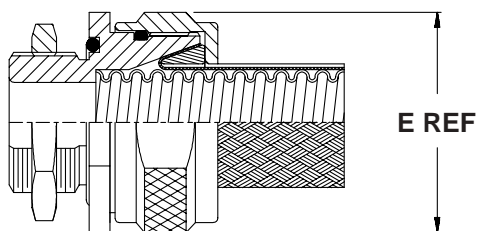

**TYPES B, D, & E  
NON-ENVIRONMENTAL**

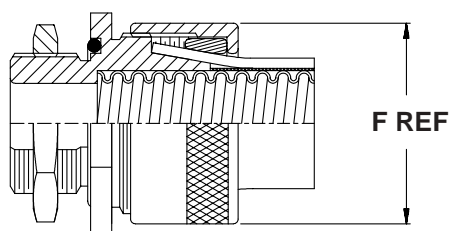

**TYPE G  
ENVIRONMENTAL**

**712-389 - Types B, C, D, E, F & G  
User-Installable Bulkhead Fitting  
for Series 74 Helical Convolved Tubing**



**TABLE I**

DASH NO.	TUBING I.D.		A THREAD CLASS 2A	B		C		D	
	MIN	MAX		+03 -00	(0.8) (0.0)	ACROSS FLAT	+000 -015	(0.0) (0.4)	
06	.181 (4.6)	.188 (4.8)	7/16 - 28 UNEF	.44	(11.2)	.937 (23.8)	.375 (9.5)		
09	.273 (6.9)	.281 (7.1)	9/16 - 24 UNEF	.50	(12.7)	1.000 (25.4)	.500 (12.7)		
10	.306 (7.8)	.312 (7.9)	9/16 - 24 UNEF	.56	(14.2)	1.062 (27.0)	.500 (12.7)		
12	.364 (9.2)	.375 (9.5)	5/8 - 24 UNEF	.63	(16.0)	1.125 (28.6)	.563 (14.3)		
14	.427 (10.8)	.437 (11.1)	11/16 - 24 UNEF	.69	(17.5)	1.187 (30.1)	.625 (15.9)		
16	.485 (12.3)	.500 (12.7)	3/4 - 20 UNEF	.75	(19.1)	1.250 (31.8)	.688 (17.5)		
20	.608 (15.4)	.625 (15.9)	7/8 - 20 UNEF	.88	(22.4)	1.375 (34.9)	.812 (20.6)		
24	.730 (18.5)	.750 (19.1)	1 - 20 UNEF	1.00	(25.4)	1.500 (38.1)	.938 (23.8)		
28	.860 (21.8)	.875 (22.2)	1 3/16 - 18 UNEF	1.19	(30.2)	1.625 (41.3)	1.125 (28.6)		
32	.975 (24.8)	1.000 (25.4)	1 5/16 - 18 UNEF	1.31	(33.3)	1.750 (44.5)	1.250 (31.8)		
40	1.205 (30.6)	1.250 (31.8)	1 1/2 - 18 UNEF	1.50	(38.1)	2.125 (54.0)	1.438 (36.5)		
48	1.437 (36.5)	1.500 (38.1)	1 3/4 - 18 UNS	1.75	(44.5)	2.437 (61.9)	1.688 (42.9)		
56	1.688 (42.9)	1.750 (44.5)	2 - 18 UNS	2.00	(50.8)	2.750 (69.9)	1.938 (49.2)		
64	1.937 (49.2)	2.000 (50.8)	2 1/4 - 16 UN	2.25	(57.2)	2.875 (73.0)	2.188 (55.6)		

**TABLE II**

DASH NO.	E MAX	F MAX
06	1.09 (27.7)	.78 (19.8)
09	1.16 (29.5)	1.03 (26.2)
10	1.22 (31.0)	1.03 (26.2)
12	1.28 (32.5)	1.03 (26.2)
14	1.34 (34.0)	1.22 (31.0)
16	1.41 (35.8)	1.28 (32.5)
20	1.53 (38.9)	1.41 (35.8)
24	1.66 (42.2)	1.53 (38.9)
28	1.78 (45.2)	1.71 (43.4)
32	1.91 (48.5)	1.84 (46.7)
40	2.28 (57.9)	2.16 (54.9)
48	2.59 (65.8)	2.46 (62.5)
56	2.91 (73.9)	2.78 (70.6)
64	3.03 (77.0)	3.03 (77.0)

**TABLE III**

SYMBOL	FINISH
B	Olive Drab over Cadmium Plate
J	Gold Iridite over Cadmium Plate over Nickel
M	Electroless Nickel
N	Olive Drab over Cadmium Plate over Nickel
NC	Zinc-Cobalt, Olive Drab
NF	Olive Drab over Cadmium Plate over Electroless Nickel (500 Hour Salt Spray)
T	Bright Dip Cadmium Plate over Nickel

**NOTES:**

1. Metric dimensions (mm) are in parentheses.
2. Tubing shown for reference only.