

## Product Data Sheet

Part No. ST-03BH Reflow Type (SMD)

### DIMENSIONS

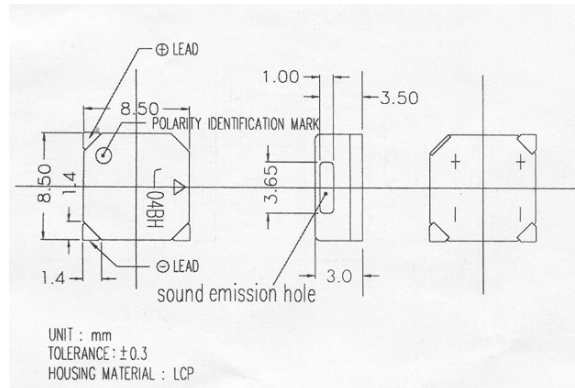
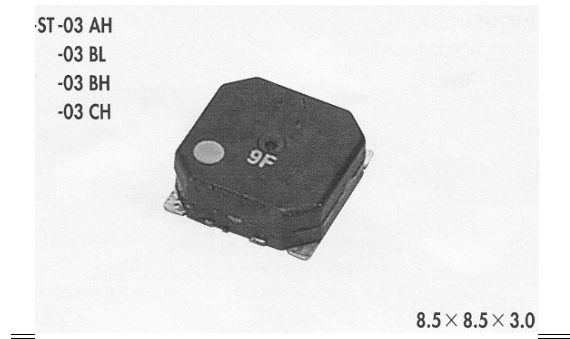

Type	Unit	
Color		Black
Rated Voltage	(V)	3.6
Operating Voltage	(V)	2-4
Current Consumption	(mA)	MAX.70
Coil Resistance	(Ω)	15±3
Sound Output (Min)	(dB)	87
Resonance Frequency	(Hz)	2730
Operating Temp	(C)	-30~+85
Storage Temp	(C)	-40~+85
Weight	(g)	1
Terminal		SMD
Dimension	mm	8.5 x 8.5 x 3

\*applied voltage: Rated Voltage, 1/2 duty, square wave

\*distance for measurement 10cm

### FREQUENCY RESPONSE

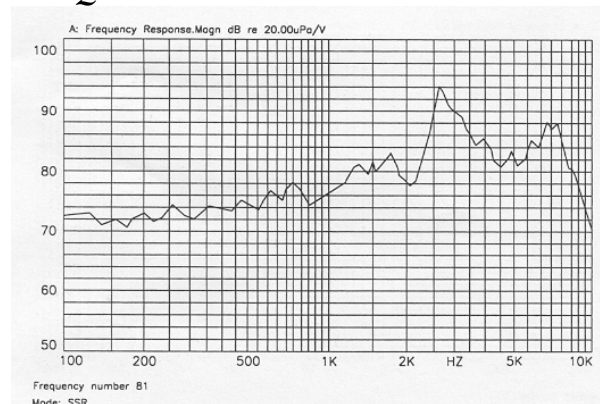

# Soberton Inc.

## Product Data Sheet

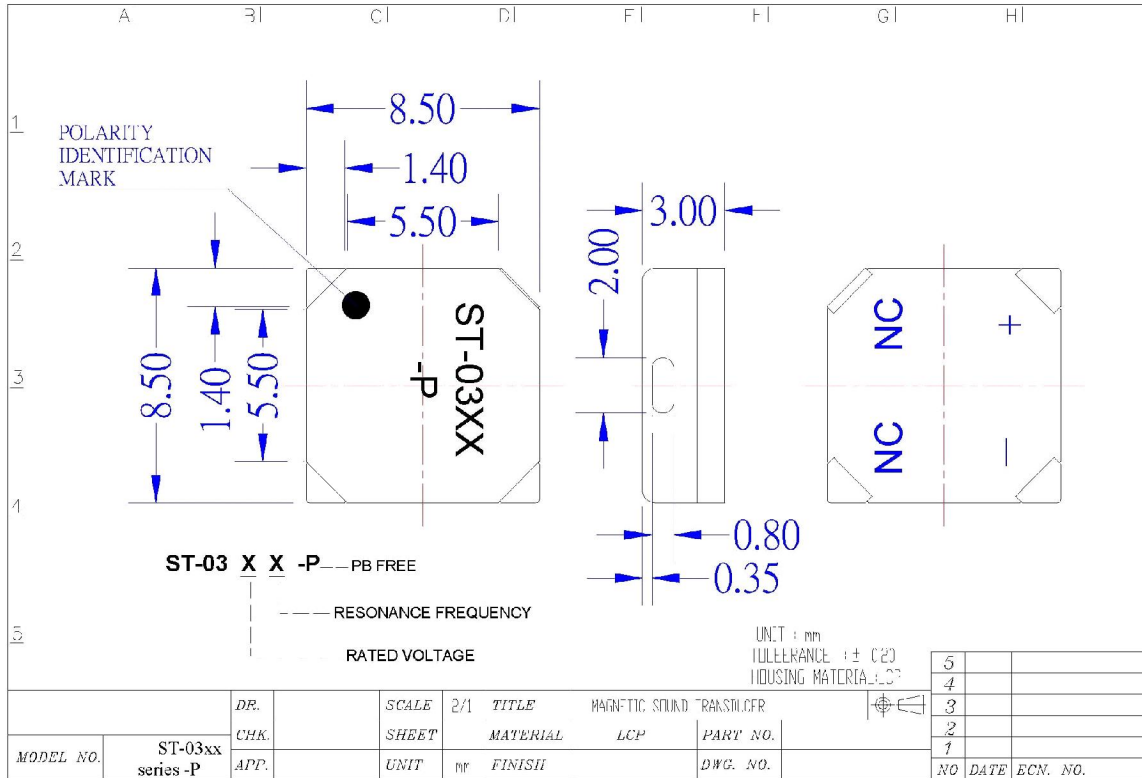

### RELIABILITY TEST

#### ST-03xx Series -P

Note: No voltage is applied to the part during reliability test No. 1~4

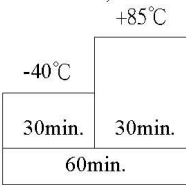
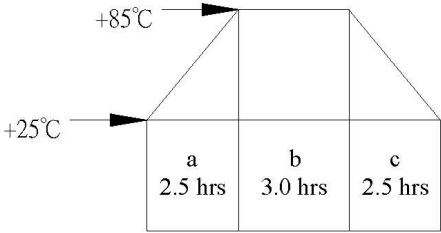
Item	Test Conditions	Evaluation Standard
1	<p>Temp. test</p> <p>(1) High temp. storage life test: The part shall be capable of withstanding a storage temperature of +85°C for 96 hours.</p> <p>(2) Low temp. storage life test: The part shall be capable of withstanding a storage temperature of -40°C for 96 hours.</p> <p>(3) Temp. cycle: The part shall be subjected to 10 cycles. One cycle shall consist of ;</p> 	<p>After the test the part shall meet specifications without any degradation in appearance and performance except SPL.</p>
2	<p>Temp. / Humidity cycle test</p> <p>The part shall be subjected to 10 cycles. One cycle shall be 8 hours and consist of ;</p>  <p>a , b : 90 ~ 98% RH c : 80 ~ 98% RH</p>	<p>SPL. shall be 87 dB or more.</p>

## RELIABILITY TEST

### ST-03xx Series -P

Note: No voltage is applied to the part during reliability test No. 1~4

Item	Test Conditions	Evaluation Standard
3	<p><b>Vibration Test</b></p> <p>The part shall be subjected to a vibration cycle of 10Hz to 55Hz to 10Hz in a period of 1 minute. Total peak amplitude shall be 1.52mm(9.3G). The vibration test shall consist of 2 hours per plane in each three mutually perpendicular planes for a total time of 6 hours.</p>	
4	<p><b>Dropping Test</b></p> <p>(1) Fixed drop : The part shall be mounted on 100g jig(standard peboard) and dropped from a height of 152cm onto a concrete floor 5 times in each 6 planes. (a total of 30 times.)</p> <p>(2) Free drop : The part only shall be dropped from a height of 75cm onto a 40mm thick wooden board 3 times in 3 axes (X.Y.Z). (a total of 9 times.)</p>	<p>After the test the part shall meet specifications without any degradation in appearance and performance except SPL.</p> <p>SPL. shall be 87 dB or more.</p>
5	<p><b>Operating life test</b></p> <p>(1) Ordinary temperature : The part shall be subjected to 1000 hours at room temperature (25±10°C) with rated voltage &amp; resonance frequency applied.</p> <p>(2) High temperature : The part shall be subjected to 500 hours at +70°C with rated voltage &amp; resonance frequency applied.</p> <p>(3) Low temperature : The part shall be subjected to 500 hours at -30°C with rated voltage &amp; resonance frequency applied.</p>	

### RELIABILITY TEST

#### ST-03xx Series -P

Note: No voltage is applied to the part during reliability test No. 1~4

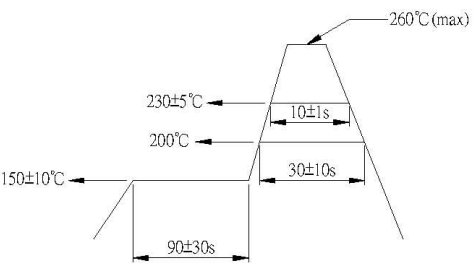
Item	Test Conditions	Evaluation Standard
6 Solderability	The part shall be dipped into the soldering bath conditioned as follows ;  Solder temp. : $260\pm 5^{\circ}\text{C}$  Soaking time : 10 - 11 seconds	95% surface of lead pins must be covered with fresh solder and soldering balls should be found.
7 Pin lead strength	3 lead pins shall be solder on the pc board , and the force (10n) shall be applied behind the part for $10\pm 1$ seconds.	
8 For infrared reflow oven	<Recommended temperature profile for reflow oven> ( Reference standard ; EIAJ ED-4702 )  	After the test the part shall meet specifications without any degradation in appearance and performance except SPL.  SPL. shall be 87 dB or more.