

# SR5000W Series

## Ultra-Miniature, SIP 50W, Wide Input Range POL Switching Regulator

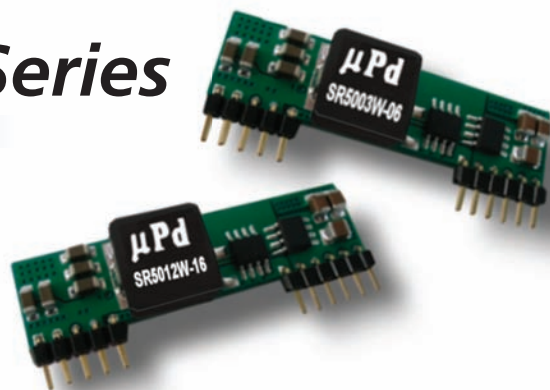

### Key Features:

- 50W Output Power
- Efficiency to 93%
- Miniature SIP Construction
- Wide Input Range
- Over Temp. Protection
- Remote On/Off
- Short Circuit Protection
- Low Cost



**RoHS Compliant**

### MicroPower Direct

292 Page Street  
Suite D  
Stoughton, MA 02072  
USA

T: (781) 344-8226  
F: (781) 344-8481  
E: sales@micropowerdirect.com  
W: www.micropowerdirect.com



### Electrical Specifications

Specifications typical @ +25°C, nominal input voltage & rated output current, unless otherwise noted. Specifications subject to change without notice.

#### Input

Parameter	Conditions	Min.	Typ.	Max.	Units
Input Voltage Range	3.3 VDC Input	3.0		5.5	VDC
	12 VDC Input	10.0		14.0	

#### Output

Parameter	Conditions	Min.	Typ.	Max.	Units
Output Voltage Accuracy				±2.0	%
Line Regulation	Vin = Min to Max			±0.5	%
Load Regulation	Iout = 0% to 100%			±0.5	%
Remote Sense Compensation				0.5	VDC
Ripple & Noise (20 MHz)				50	mV P - P
Rise Time			1.5		mS
Turn On Delay	Full Resistive Load		2		mS
Transient Recovery Time	75% Load Step Change		50		μSec
Transient Response Deviation		±5.0	±10.0	%	
Temperature Coefficient			±0.02		%/°C
Overtemperature Protection	See Note 1			115	°C
Maximum Capacitive Loading	Min ESR > 10 mΩ			5,000	μF
Output Short Circuit	Continuous (Autorecovery)				

#### General

Parameter	Conditions	Min.	Typ.	Max.	Units
Isolation Voltage	Not Isolated				
Switching Frequency			300		kHz

#### Environmental

Parameter	Conditions	Min.	Typ.	Max.	Units
Operating Temperature Range	Case	-40	+25	+85	°C
Storage Temperature Range		-55		+125	°C
Cooling	Free Air Convection				
Humidity	RH, Non-condensing			95	%

#### Physical

Size	2.0 x 0.28 x 0.5 Inches (50.8 x 7.1 x 12.7 mm)				
Weight	0.19 Oz (6.0g)				

#### Reliability Specifications

Parameter	Conditions	Min.	Typ.	Max.	Units
MTBF	MIL HDBK 217F, 25°C, Gnd Benign	2.0			MHours
Flammability Rating	UL94V-0				

#### Absolute Maximum Ratings

Parameter	Conditions	Min.	Typ.	Max.	Units
Input Voltage Surge (1 Sec)	5 VDC Input	-0.7		6.0	VDC
	12 VDC Input	-0.7		16.0	
Pin Solder Temperature	Wave Solder <10S			250.0	°C
Hand Solder Temperature	425°C Iron Temperature			5.0	Sec

## Model Selection Guide

Model Number	Input		Output	
	Voltage (VDC)		Voltage (VDC)	Current (A, Max)
	Nominal	Range		
SR5003W-06	3.3	3.0 - 5.5	0.75 - 3.3	6.0
SR5003W-10	3.3	3.0 - 5.5	0.75 - 3.3	10.0
SR5003W-16	3.3	3.0 - 5.5	0.75 - 3.3	16.0
SR5012W-06	12	10.0 - 14.0	0.75 - 5.0	6.0
SR5012W-10	12	10.0 - 14.0	0.75 - 5.0	10.0
SR5012W-16	12	10.0 - 14.0	0.75 - 5.0	16.0

### Notes:

1. An overtemperature protection circuit shuts down the converter if the temperature at the output inductor exceeds 115°C. The unit will restart automatically when the temperature at the output inductor drops below 110°C.
2. For a 3.3V output, the input range is 4.0 to 5.5 VDC
3. No minimum load is required. Operation at no-load will not damage these units.
4. These converters require no additional external components to meet specifications. However, using external capacitors as shown in the typical connection drawing at right may lower noise in some applications.
5. Transient recovery is measured to within a 1% error band for a load step change of 25% to 100%.
6. It is recommended that a fuse be used on the input of a power supply for protection. Contact the factory for the correct rating.

## Typical Connection Diagram

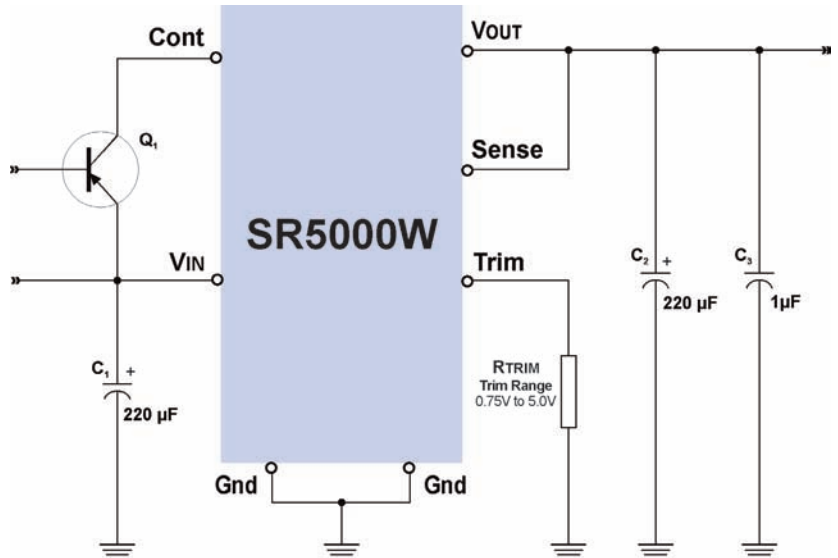

1. C1 and C2 are Electrolytic capacitors. C2 should have a low ESR. C3 is a ceramic capacitor.
2. When not being used, the Remote Sense pin (pin 3) should be connected to VOUT as close to the converter as possible.
3. The output voltage of the SR50xxW may be trimmed down by connecting an external resistor between the Trim Pin (pin 10) and Ground (pins 5 & 6). This resistor value (in kΩ) is given by:

$$\text{SR5003W-xx} \quad R_{\text{TRIM}} = \frac{21.07}{(V_o - 0.7525)} - 5.11$$

$$\text{SR5012W-xx} \quad R_{\text{TRIM}} = \frac{10.5}{(V_o - 0.7525)} - 1.0$$

RTrim values for typical output levels are:

Output Voltage	SR5003W-xx	SR5012W-xx
0.75 VDC	Open	Open
1.00 VDC	80.021 kΩ	41.424 kΩ
1.20 VDC	41.973 kΩ	22.460 kΩ
1.50 VDC	23.077 kΩ	13.050 kΩ
1.80 VDC	15.004 kΩ	9.024 kΩ
2.00 VDC	11.779 kΩ	7.416 kΩ
2.50 VDC	6.947 kΩ	5.009 kΩ
3.30 VDC	3.160 kΩ	3.122 kΩ
5.00 VDC	---	1.472 kΩ

## Derating Curve

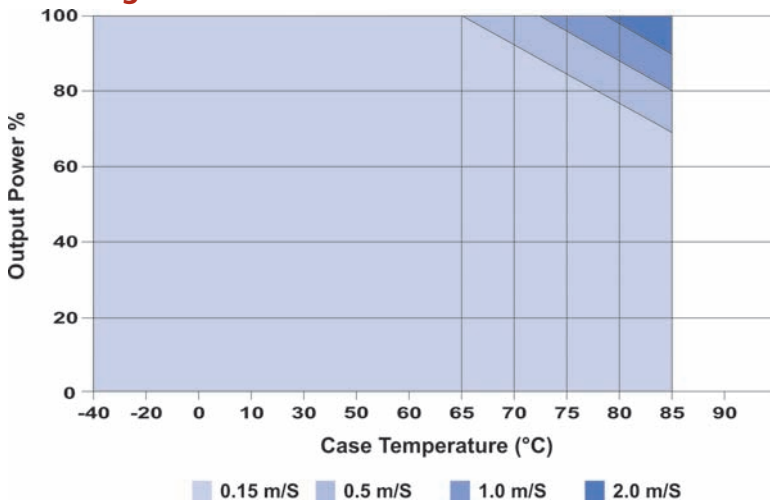

## Pin Connections

Pin	1	2	3	4	5	6	7	8	9	10	11
1	Vout	Vout	Sen	Vout	Gnd	Gnd	Vin	Vin	NC	Trim	Cont

4. The Control input (pin 11) uses TTL compatible logic as follows:

Unit	Control Pin
ON	Open or VIN
OFF	Grnd or < 0.4V

## Mechanical Dimensions

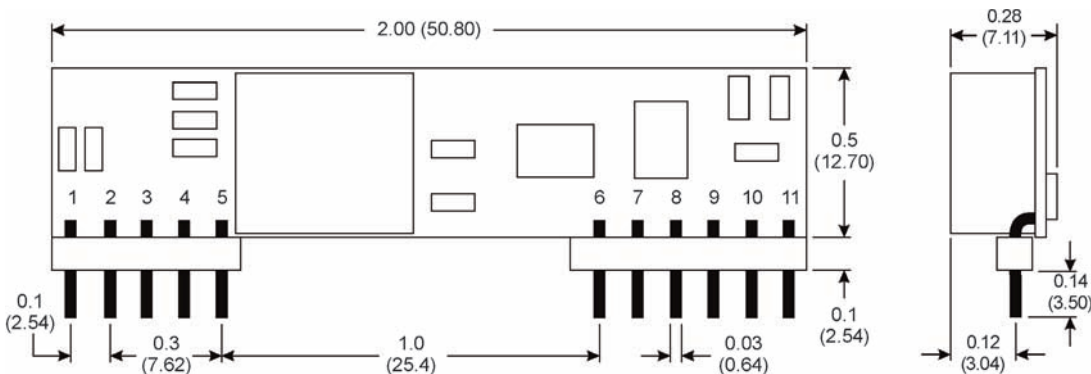

**MicroPower Direct**  
www.micropowerdirect.com

### Notes:

- All dimensions are typical in inches (mm)
- Tolerance x.xx = ±0.01 (±0.25)