

## Product Specification: SP0103 Series with Integrated Amplifier

This document applies the following SiSonic Model Numbers:

SP0103NC3-2

SP0103NC3-3

SiSonic microphone with integrated amplifier offers designers numerous features: up to 20dB gain, surface-mountable, compatible with standard solder reflow, pick-and-place with standard high speed automated equipment, low output impedance, and excellent environmental characteristics. External amplifiers amplify both signal and external noise induced in the circuit, compared to SiSonic SP0103 that amplifies the signal prior to external noise.

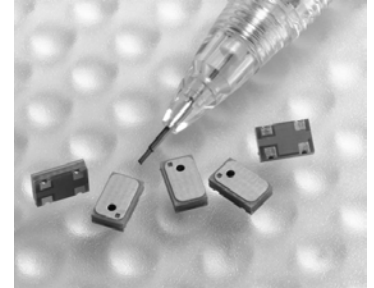

### Microphone Dimensional Layout

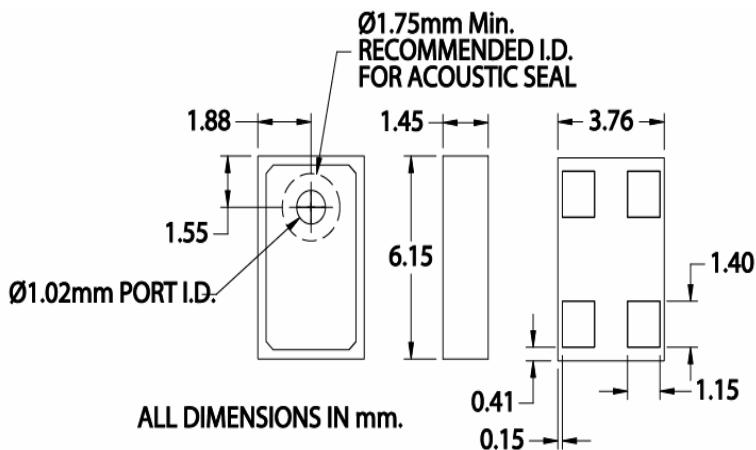

Item	Dim.	Tol. (+/-)	Unit
Height	1.45	0.15	mm
Length	6.15	0.05	mm
Width	3.76	0.05	mm
Weight	~0.09	grams	
Coplanarity	< 0.1		mm

### Microphone Pin Output

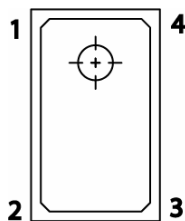

PIN#	FUNCTION
1	OUTPUT
2	GAIN CONTROL
3	GROUND
4	POWER

### Recommended PCB Land Layout

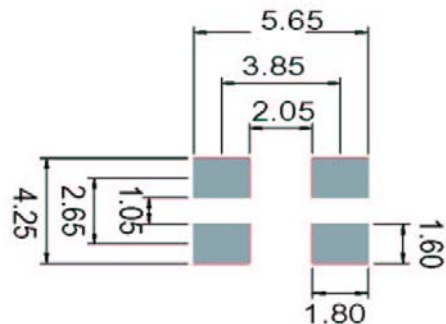

**Product Specifications**

Test Conditions: +20°C, 60-70% R.H.

	Symbol	Condition	Limits			Unit
			Min.	Nom.	Max.	
Directivity		Omni-directional				
Sensitivity	S	@ 1kHz (0dB=1V/Pa) where R3=0Ω, C1=0.47uF	-26	-22	-18	dB
Output impedance	Z <sub>OUT</sub>	@ 1kHz (0dB=1V/Pa)			100	Ω
Current Consumption	I <sub>DSS</sub>	across 1.5 to 5.5 volts	0.100		0.350	mA
Signal to Noise Ratio	S/N	@ 1kHz (0dB=1V/Pa)	55	59		dB
Typical Input Referred Noise	ENL	A-weighted		35		dBA SPL
Supply Voltage	Vs		1.5		5.5	V
Sensitivity Loss across Voltage		Change in sensitivity over 5.5v to 1.5v	No Change Across Voltage Range			dB
Maximum Input Sound Level		At 100dB SPL, THD < 1% At 115dB SPL, THD < 10%				dB
Operating Temperature			-40		+100	°C
Storage Temperature			-40		+100	°C
Frequency Range		100 – 10,000				Hz

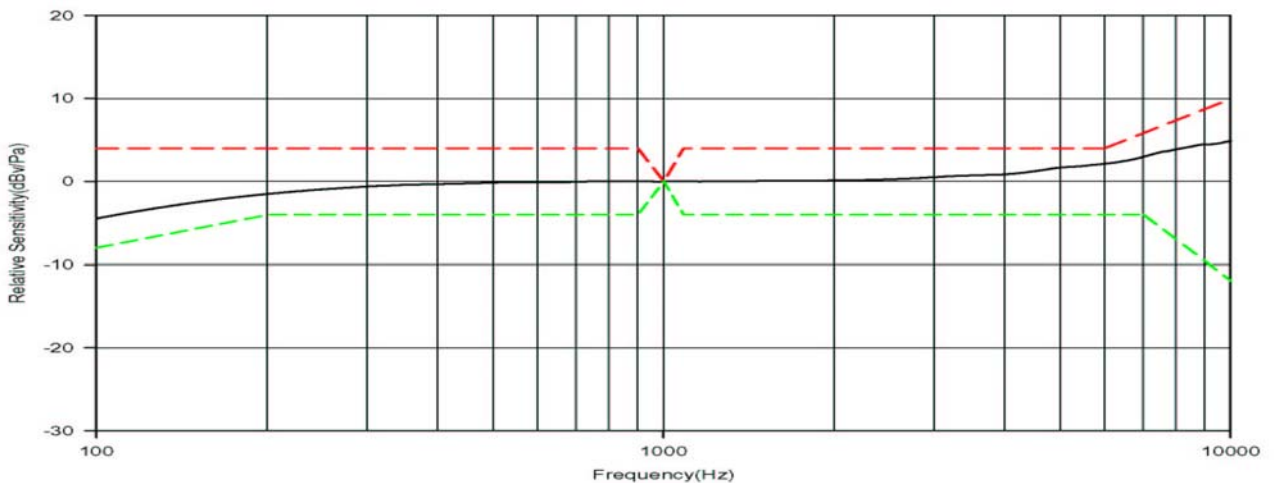
**Frequency Response Curve**

## Packaging Specifications

### Carrier – Tape Detail

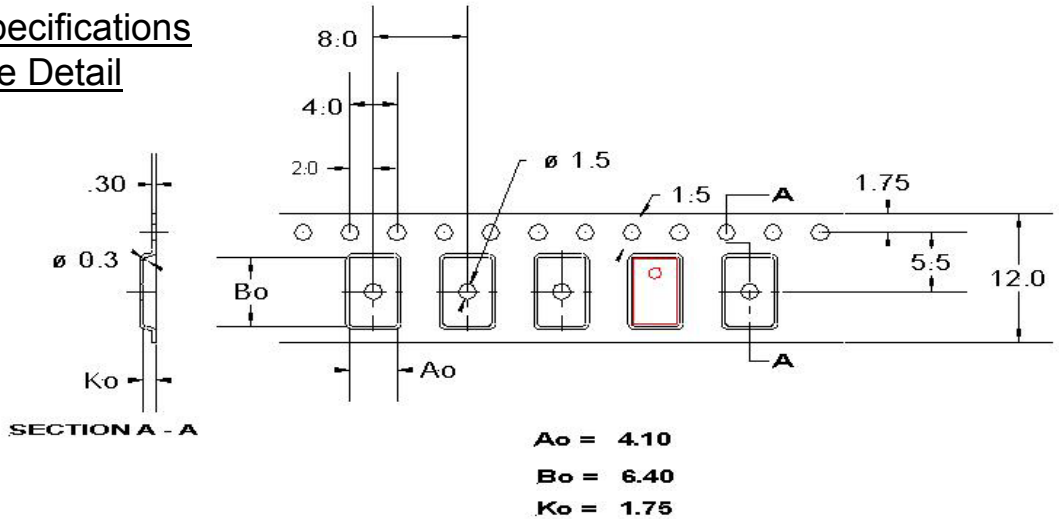

Model Number	Suffix	Reel Diameter	Qty per Reel
SP0103NC3	-2	7"	1,200
SP0103NC3	-3	13"	4,500

NOTE: All devices are lead-free and compatible with lead-free reflow profile.

Tape & Reel	Available in 7" or 13" diameter.
Leader Length	800mm or minimum of 100 empty pockets
Label	Label applied to external package and direct to reel. Per JEDEC.
Storage Life	1 year storage (original packaging, low humidity)
Polarity of part	"L" – direction

## Solderability Characteristics

Solder Reflow	260°C for maximum 30 seconds
Conditions:	<b>Do not board wash after reflow.</b> <b>Do not pull vacuum directly over acoustic port hole.</b>

Reflow Profile (Maximum Conditions)

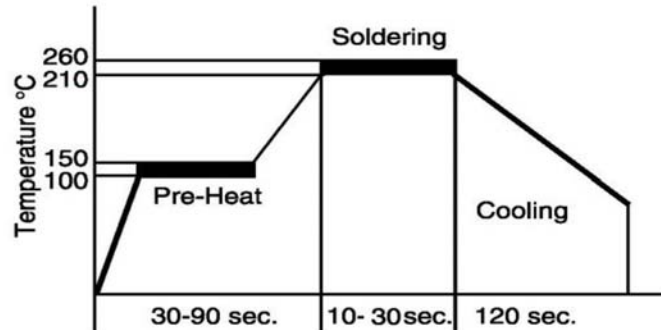

## Reliability

Note: After test conditions are performed, the sensitivity of the microphone shall not deviate more than 3dB from its initial value.

Thermal Shock	Microphone unit must operate when exposed to air-to-air thermal shock 100 cycles, from $-40^{\circ}\text{C}$ to $+125^{\circ}\text{C}$ . (IEC 68-2-4)
High Temperature Storage Test	Microphone unit must maintain sensitivity after storage at $+105^{\circ}\text{C}$ for 1,000 hours. (IEC 68-2-2 Test Ba)
Low Temperature Storage Test	Microphone unit must maintain sensitivity after storage at $-40^{\circ}\text{C}$ for 1,000 hours. (IEC 68-2-1 Test Aa)
High Temperature Operating Test	Microphone unit must operate within sensitivity specifications for 16 hours at $105^{\circ}\text{C}$ . (IEC 68-2-2 Test Ba)
Low Temperature Operating Test	Microphone unit must operate within sensitivity specifications for 16 hours at $-40^{\circ}\text{C}$ . (IEC 68-2-1 Test Aa)
Humidity Test	Tested under Bias at $85^{\circ}\text{C}/85\%$ R.H. for 270 hours. (JESD22-A101A-B)
Vibration Test	Microphone unit must operate under test condition: 4 cycles, from 20 to 2,000 Hz in each direction (x,y,z), 48 minutes, using peak acceleration of 20g (+20%, -0%). (MIL 883E, method 2007.2, A)
Electrostatic Discharge	Tested to 8kV direct contact discharge or 15kV air discharge as specified by IEC 1000-4-2, level 3 and level 4.
Reflow	Microphone is tested to 5 passes through reflow oven under conditions of $260^{\circ}\text{C}$ for 30 seconds maximum.
Mechanical Shock	Tested to 5,000g (IEC 68-2-27, Ea).

## Recommended Interface Circuit for SP0103N Integrated Amplifier

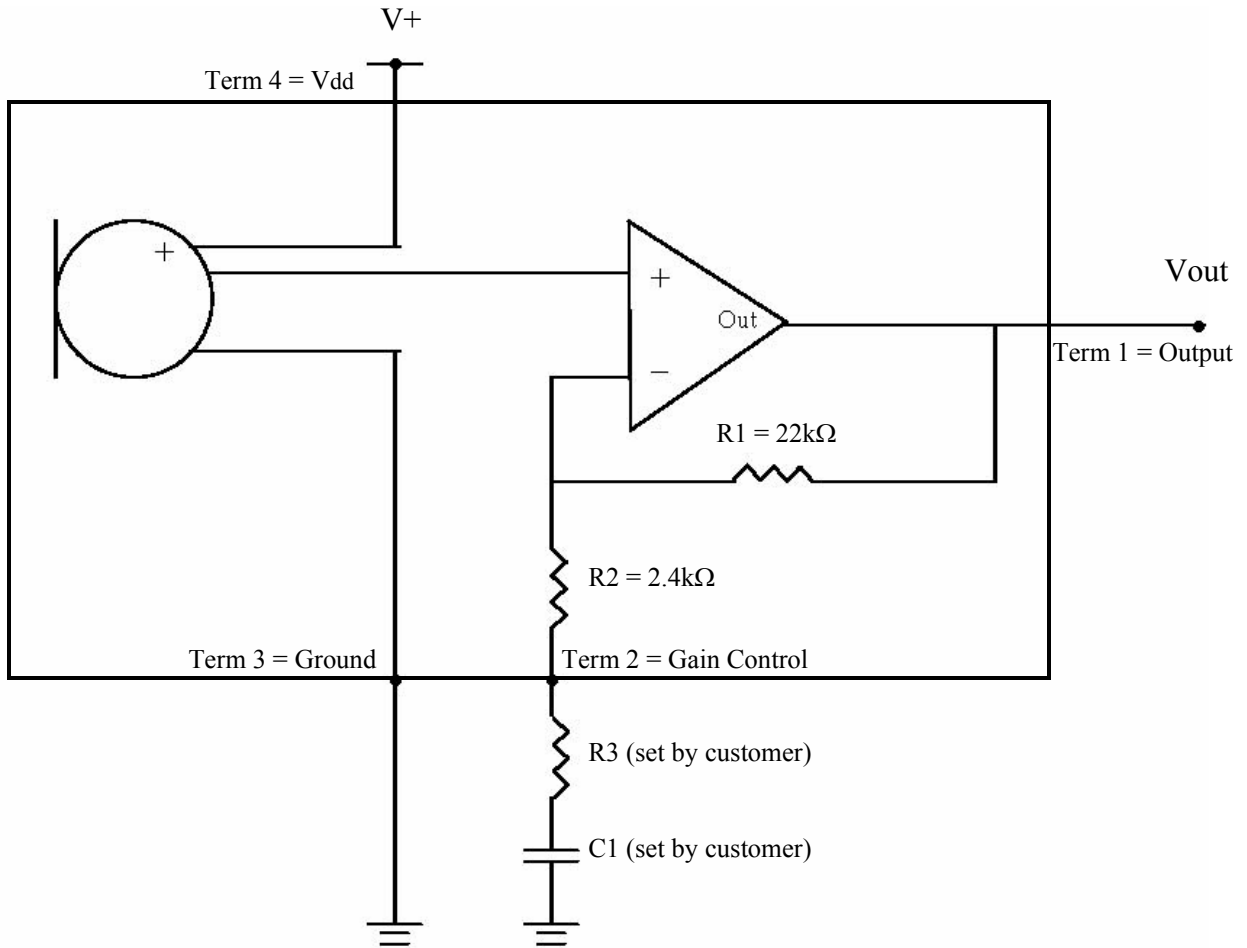

<b>Desired Gain</b>	<b>Pin 2 Termination Method</b>
Unity Gain (0dB)	Tie Terminal 2 directly to Output (Terminal 1).
20dB Gain	Tie Terminal 2 through C1 (0.47uF) to Ground.
Adjustable Gain	Add R3 and C1. Use formulas provided to calculate settings, or contact Knowles for support.

### Setting Gain Formulas:

Gain of non-inverting Op-Amp is determined as:

$$\rightarrow G = 1 + \left\{ \frac{R1}{R2 + R3} \right\} \quad \text{Gain(dB)} = 20 * \log(G)$$

High-pass-filter Corner Frequency:

$$\rightarrow \text{C.F.} = 1 / \{ 2 * \pi * (R2 + R3) * C1 \}$$