

1000W Single Output Power Supply

RSP-1000 series



■ Features :

- Universal AC input / Full range
- AC input active surge current limiting
- Built-in 5V/0.5A auxiliary power
- Built-in active PFC function, PF>0.95
- Protections: Short circuit/Over load/Over voltage/Over temperature
- Output voltage can be trimmed between 40 ~ 110% of the rated output voltage
- Forced air cooling by built-in DC fan
- High power density 10.7w/inch³
- 1U low profile 41mm
- Active current sharing up to 4000W(3+1) (Note.8)
- DC OK Signal
- Built-in remote ON-OFF control
- Built-in remote sense function
- 3 years warranty



SPECIFICATION

MODEL	RSP-1000-12	RSP-1000-15	RSP-1000-24	RSP-1000-27	RSP-1000-48	
OUTPUT	DC VOLTAGE	12V	15V	24V	27V	48V
	RATED CURRENT	60A	50A	40A	37A	21A
	CURRENT RANGE	0 ~ 60A	0 ~ 50A	0 ~ 40A	0 ~ 37A	0 ~ 21A
	RATED POWER	720W	750W	960W	999W	1008W
	RIPPLE & NOISE (max.) Note.2	150mVp-p	150mVp-p	150mVp-p	150mVp-p	150mVp-p
	VOLTAGE ADJ. RANGE	10 ~ 13.5V	13.5 ~ 16.5V	20 ~ 26.4V	24 ~ 30V	43 ~ 55V
	VOLTAGE TOLERANCE Note.3	±1.0%	±1.0%	±1.0%	±1.0%	±1.0%
	LINE REGULATION	±0.5%	±0.5%	±0.5%	±0.5%	±0.5%
	LOAD REGULATION	±0.5%	±0.5%	±0.5%	±0.5%	±0.5%
	SETUP, RISE TIME	300ms, 50ms at full load				
	HOLD TIME (Typ.)	16ms/230VAC	16ms/115VAC at full load			
INPUT	VOLTAGE RANGE Note.5	90 ~ 264VAC	127 ~ 370VDC			
	FREQUENCY RANGE	47 ~ 63Hz				
	POWER FACTOR (Typ.)	0.95/230VAC	0.98/115VAC at full load			
	EFFICIENCY (Typ.)	83%	85%	88%	88%	90%
	AC CURRENT (Typ.)	12A/115VAC	6A/230VAC			
	INRUSH CURRENT (Typ.)	25A/115VAC	40A/230VAC			
LEAKAGE CURRENT	<2.0mA / 240VAC					
PROTECTION	OVER LOAD	105 ~ 125% rated output power Protection type : Constant current limiting, recovers automatically after fault condition is removed				
	OVER VOLTAGE	13.8 ~ 16.8V	17 ~ 20.5V	27.6 ~ 32.4V	31 ~ 36.5V	56.6 ~ 66.2V
	OVER TEMPERATURE	85°C ±5°C (TSW2) Detect on heatsink of O/P diode; 75°C ±5°C (TSW1) Detect on heatsink of power transistor Protection type : Shut down o/p voltage, recovers automatically after temperature goes down				
FUNCTION	AUXILIARY POWER(AUX)	5V @ 0.5A (+5%, -8%)				
	REMOTE ON/OFF CONTROL Note.6	Power on : short between on/off(pin6) & -S(pin2) on CN50			Power off : open between on/off(pin6) & -S(pin2) on CN50	
	DC OK SIGNAL	Open collector signal low when PSU turns on, Max. sink current : 10mA				
	OUTPUT VOLTAGE TRIM Note.6	Adjustment of output voltage is possible between 40 ~ 110% of rated output				
CURRENT SHARING(CS)Note.7	Please refer to function manual					
ENVIRONMENT	WORKING TEMP.	-20 ~ +60°C (Refer to output load derating curve)				
	WORKING HUMIDITY	20 ~ 90% RH non-condensing				
	STORAGE TEMP., HUMIDITY	-40 ~ +85°C, 10 ~ 95% RH				
	TEMP. COEFFICIENT	±0.02%/°C (0 ~ 50°C)				
	VIBRATION	10 ~ 500Hz, 2G 10min./1cycle, 60min. each along X, Y, Z axes				
SAFETY & EMC (Note 4)	SAFETY STANDARDS	UL60950-1, TUV EN60950-1 Approved				
	WITHSTAND VOLTAGE	I/P-O/P:3KVAC I/P-FG:1.5KVAC O/P-FG:0.5KVAC				
	ISOLATION RESISTANCE	I/P-O/P, I/P-FG, O/P-FG:100M Ohms/500VDC				
	EMI CONDUCTION & RADIATION	Compliance to EN55022 (CISPR22)				
HARMONIC CURRENT	Compliance to EN61000-3-2,-3					
EMS IMMUNITY	Compliance to EN61000-4-2,3,4,5,6,8,11; ENV50204, EN55024, EN61000-6-2, EN61204-3 Heavy industry level, criteria A					
OTHERS	MTBF	35K hrs min. MIL-HDBK-217F (25°C)				
	DIMENSION	295*127*41mm (L*W*H)				
	PACKING	1.95Kg; 6pcs/12.7Kg/0.99CUFT				
NOTE	1. All parameters NOT specially mentioned are measured at 230VAC input, rated load and 25°C of ambient temperature. 2. Ripple & noise are measured at 20MHz of bandwidth by using a 12" twisted pair-wire terminated with a 0.1uf & 47uf parallel capacitor. 3. Tolerance : includes set up tolerance, line regulation and load regulation. 4. The power supply is considered a component which will be installed into a final equipment. The final equipment must be re-confirmed that it still meets EMC directives. 5. Derating may be needed under low input voltages. Please check the derating curve for more details. 6. The power supply unit will have no output if the shorting connector is not assembled. It contains two shorting wires: one is from on/off(pin6) to -s(pin2) and the other is from Vco(pin8) to Vca(pin10). Please refer to function manual for details. 7. In parallel connection, maybe only one unit operate if the total output load is less than 5% of rated load condition. 8. Please consult MEAN WELL for applications of more units connecting in parallel.					

Mechanical Specification

Case No. 952B Unit:mm

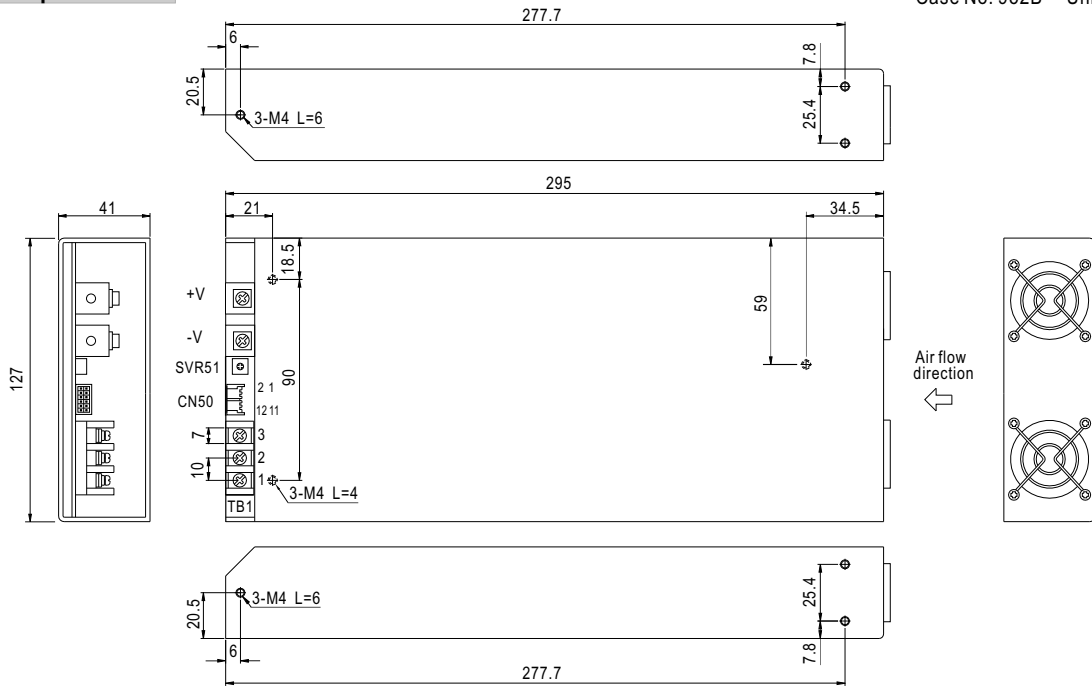

AC Input Terminal Pin. No. Assignment

Pin No.	Assignment
1	AC/N
2	AC/L
3	FG \perp

Control pin number assignment (CN50) : JST B12B-PHDSS or equivalent

Pin No.	Assignment	Pin No.	Assignment	Pin No.	Assignment	Mating Housing	Terminal
1	+S	5	DC-OK	9	Vci	JST PHDR-12VS or equivalent	JST SPHD-002T-P0.5 or equivalent
2	-S	6	ON/OFF	10	Vca		
3	G-AUX	7	CS	11,12	GND		
4	5V-AUX	8	Vco				

Block Diagram

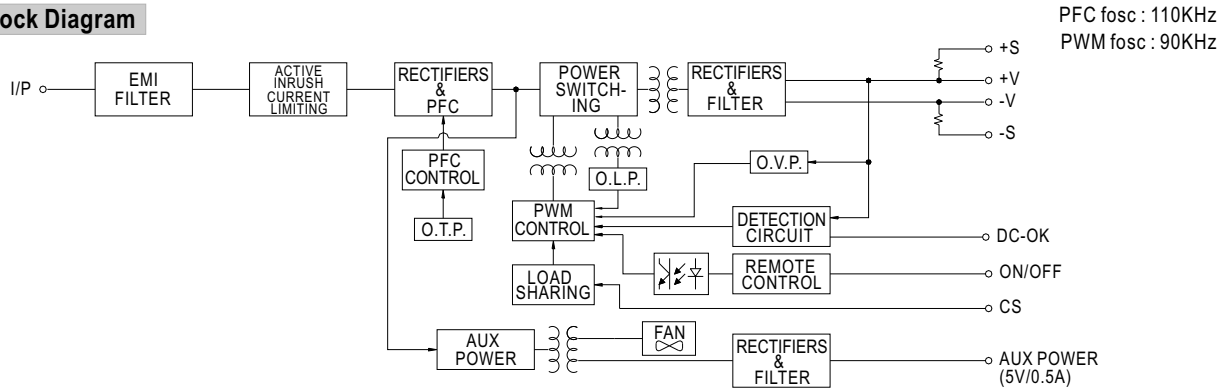

PFC fosc : 110KHz
PWM fosc : 90KHz

Derating Curve

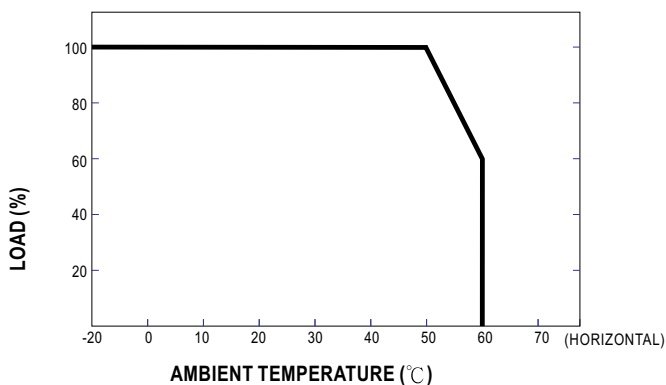

Static Characteristics

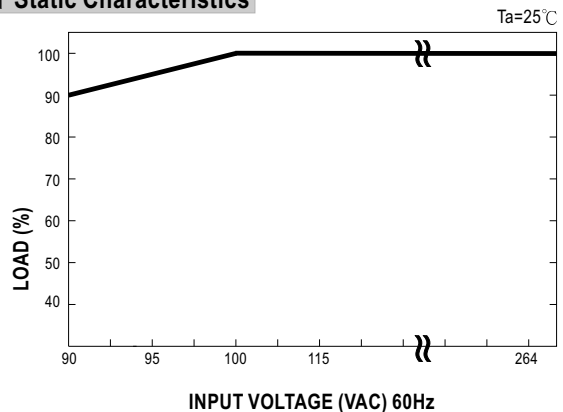

Function Description of CN50

Pin No.	Function	Description
1	+S	Positive sensing. The +S signal should be connected to the positive terminal of the load. The +S and -S leads should be twisted in pair to minimize noise pick-up effect. The maximum line drop compensation is 0.5V.
2	-S	Negative sensing. The -S signal should be connected to the negative terminal of the load. The -S and +S leads should be twisted in pair to minimize noise pick-up effect. The maximum line drop compensation is 0.5V.
3	G-AUX	Auxiliary voltage output ground. The signal return is isolated from the output terminals (+V & -V).
4	5V-AUX	Auxiliary voltage output, 4.6~5.25V, referenced to pin 3(G-AUX). The maximum load current is 0.5A. This output has the built-in oring diodes and is not controlled by the "remote ON/OFF control".
5	DC_OK	Open collector signal, referenced to pin11,12(GND). Low when PSU turns on. The maximum sink current is 10mA and the maximum external voltage is 5.6V.
6	ON/OFF	Turns the output on and off by electrical or dry contact between pin 6 (ON/OFF) and pin 2 (-S). Short: Power ON, Open: Power OFF.
7	CS	Current sharing signal. When units are connected in parallel, the CS pins of the units should be connected to allow current balance between units.
8	Vco	Short connecting between Vco (pin8) and Vca (pin10) if output voltage trim function is not used.
9	Vci	Connect to external DC voltage source for output voltage trimming, referenced to pin 2 (-S). Output voltage can be trimmed between 40 ~ 110% of the rated output voltage.
10	Vca	Connect to external resistor (1/8W) for output voltage trimming. Output voltage can be trimmed between 40 ~ 110% of the rated output voltage. Please refer to function manual for details.
11,12	GND	These pins connect to the negative terminal (-V). Return for DC_OK Signal output.

Function Manual

1. "Remote ON/OFF" and "Output voltage trim" functions are not used.

The power supply unit will have no output if the shorting connector (accessory comes along with the PSU) is not assembled. It contains two shorting wires : one is from ON/OFF (pin6) to -S (pin2) and the other is from Vco (pin8) to Vca (pin10).

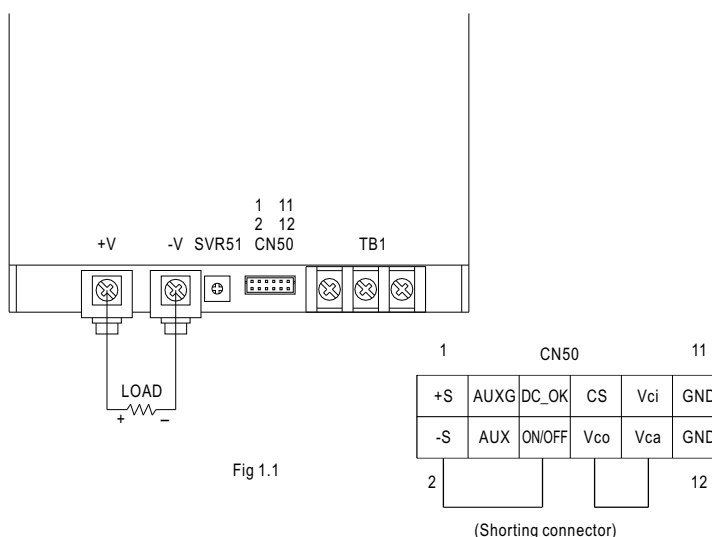
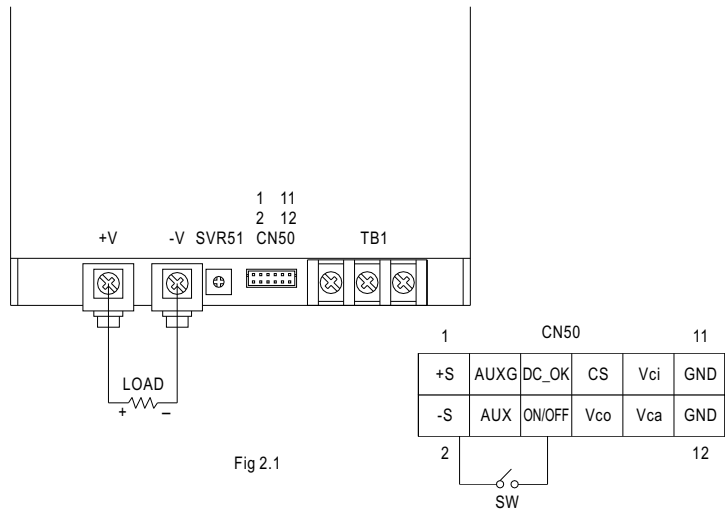

Fig 1.1

2. Remote ON/OFF

The PSU can be turned ON/OFF by using the "Remote ON/OFF" function

Between ON/OFF(pin6) and -S(pin2)	Output Status
SW ON (Short)	ON
SW OFF (Open)	OFF



3. DC_OK signal

"DC_OK" is an open collector signal. It indicates the output status of the PSU. It can operate in two ways : One is sinking current from external TTL signal ; the other is sending out a TTL voltage signal.

3-1 Sink current :

The maximum sink current is 10mA and the maximum external voltage is 5.6V.

3-2 TTL voltage signal :

Between DC- OK(pin5) and GND(pin11&12)	Output Status
0 ~ 1V	ON
3.3 ~ 5.6V	OFF

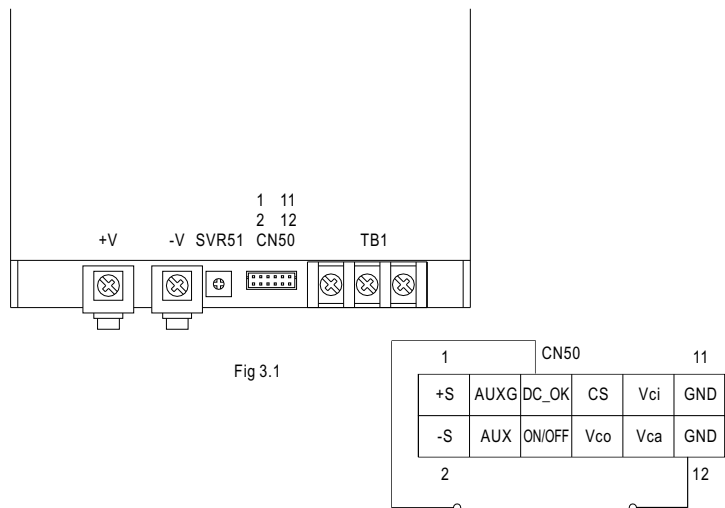

4. Remote Sense

The remote sensing compensates voltage drop on the load wiring up to 0.5V.

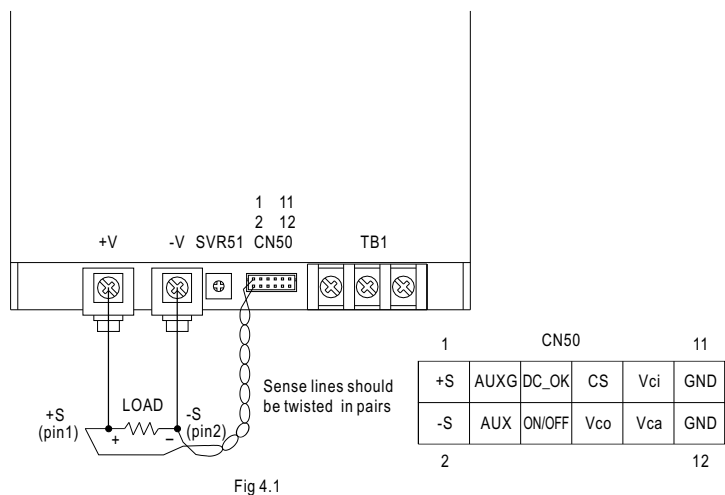

5. Output Voltage TRIM

Output voltage of RSP-1000 can be trimmed between 40% ~ 110% of its rated value by the following methods :

(1) Using external voltage source between "Vci"(pin9) and "-S"(pin2) that is shown in Fig5.1

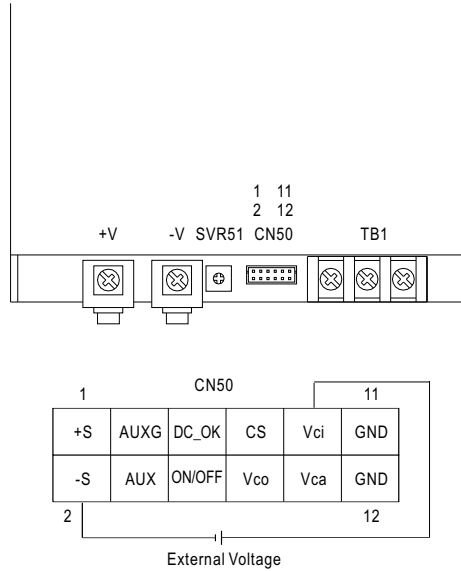
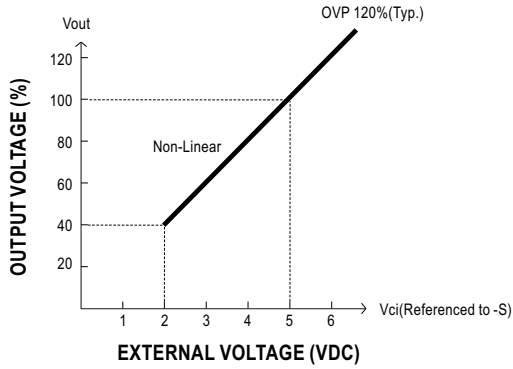

Fig 5.1

(2) Connecting a resistor externally that in shown in Fig 5.2 & Fig 5.3
 (A) O/P voltage goes down

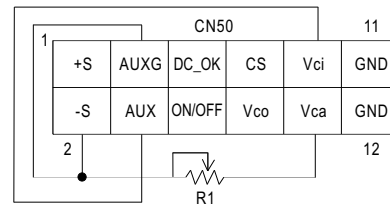
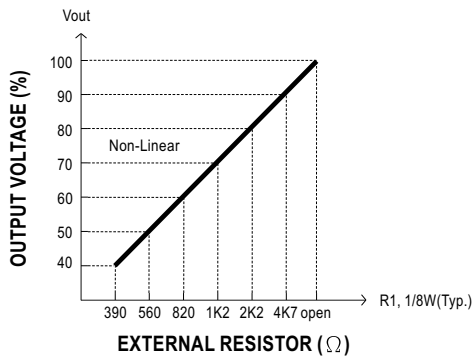

Fig 5.2

(B) O/P voltage goes up

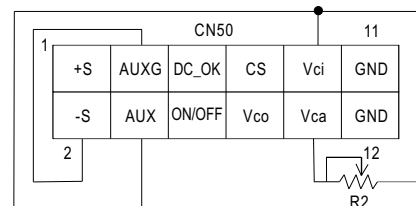
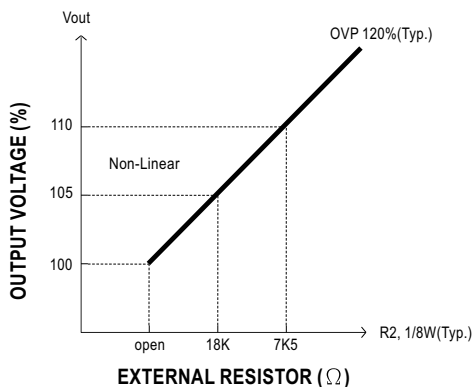

Fig 5.3

6. Current Sharing with Remote Sensing

RSP-1000 has the built-in active current sharing function and can be connected in parallel to provide higher output power :

- (1) Parallel operation is available by connecting the units shown as below.
(+S,-S and CS are connected mutually in parallel).
- (2) Difference of output voltages among parallel units should be less than 2%.
- (3) The total output current must not exceed the value determined by the following equation.
(output current at parallel operation)=(Rated current per unit)×(Number of unit)×0.9
- (4) In parallel operation 4 units is the maximum, please consult the manufacturer for applications of more connecting in parallel.
- (5) The power supplies should be paralleled using short and large diameter wiring and then connected to the load.

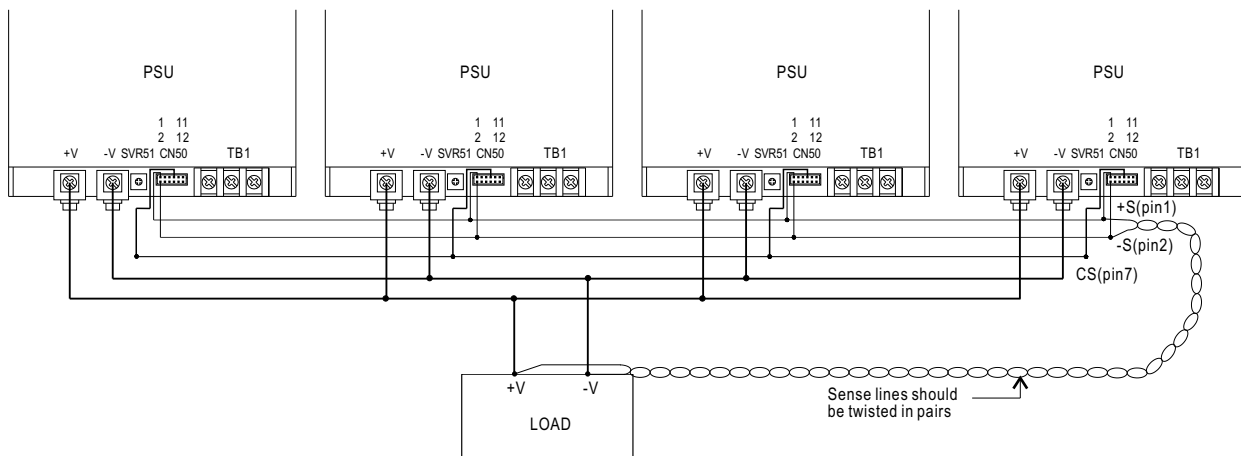

Fig 6.1

1	CN50				11
+S	AUXG	DC_OK	CS	Vci	GND
-S	AUX	ON/OFF	Vco	Vca	GND
2					12

Note : In parallel connection, maybe only one unit (master) operate if the total output load is less than 5% of rated load condition.
The other PSUs (slaves) may go into standby mode and their output LEDs will not turn on.