

OV5642 5 megapixel product brief



the world's first 1/4-inch 5 megapixel SOC image sensor with OmniBSI™ technology

The OV5642 is the world's first 1/4-inch, 5 megapixel SOC CameraChip™ sensor featuring OmniVision's most advanced 1.4 micron OmniBSI backside illumination architecture and TrueFocus™ ISP. It provides the full functionality of a complete camera on a single chip, including anti-shake technology, auto focus control, MIPI and high definition support (720p and 1080p). The OV5642 delivers best-in-class streaming video and photography for camera phone applications, creating the ultimate imaging experience.

The low-voltage OV5642 provides full-frame, sub-sampled, windowed or scaled 8-bit/10-bit images in various formats over a serial camera control bus (SCCB) interface or high speed MIPI interface. It operates at up to 15 frames per second (fps) in full resolution with full user control over image quality, format and image data output transfer. An integrated JPEG compression engine simplifies data transfer for bandwidth limited interfaces.

The OV5642 features an embedded microcontroller to support an internal auto focus engine, a programmable general purpose I/O for external auto focus control, and an internal anti-shake engine for image stabilization. It uses proprietary sensor technology to improve image quality by reducing or eliminating common lighting and/or electrical sources of image contamination to produce a clean, fully stable, color image. All required image processing functions, including exposure control, white balance, defective pixel canceling and noise cancelling are programmable through the SCCB interface, MIPI interface or the integrated microcontroller.

The OV5642 offers bridging and daisy chain support, which allows secondary cameras to share the use of its TrueFocus ISP via the DVP, while providing continued output through the MIPI interface

applications

- mobile phones
- PC multimedia
- games/toys

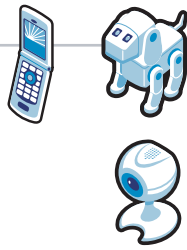

OV5642

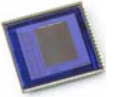

ordering information

- **OV5642-A63A**
(color, lead-free, 63-pin CSP3)
- **OV5642-G04A**
(color, chip probing, 200 µm backgrinding, reconstructed wafer)

product features

- 1.4 micron OmniBSI technology
- ultra high performance
- embedded TrueFocus™ ISP, enabling better denoise, sharpening, gamma correction and color correction
- automatic image control functions: automatic exposure control (AEC), automatic white balance (AWB), automatic band filter (ABF), automatic 50/60 Hz luminance detection, automatic black level calibration (ABLC)
- programmable controls for frame rate, AEC/AGC 16-zone size/position/weight control, mirror and flip, scaling, cropping, windowing, and panning
- image quality controls: color saturation, hue, gamma, sharpness, lens correction, defective pixel cancelling, and noise cancelling
- support for output formats: RAW RGB, RGB565/555/444, CCIR656, YUV422/420, YCbCr422, and compression
- support for auto focus control (AFC)
- standard serial SCCB interface
- MIPI serial input/output interface
- programmable I/O drive capability
- support for mechanical shutter, ND filter and IRIS control
- built-in 1.5V regulator for core

product specifications

- **optical format:** 1/4"
- **array size:** 2592 x 1944
- **power supply:**
 - core: 1.5VDC ± 5% (internal regulator)
 - analog: 2.6 - 3.0V
 - I/O: 1.7 - 3.0V
- **power consumption:** TBD
- **dynamic range:** TBD
- **pixel size:** 1.4 µm x 1.4 µm
- **frame rate:**
 - **5 megapixel (2592 x 1944):** 15 fps (and any size scaling down from 5 megapixel)
 - **1080p (1920 x 1080):** 30 fps
 - **720p (1280 x 720):** 60 fps
 - **VGA (640 x 480):** 60 fps
 - **QVGA (320 x 240):** 120 fps
- **image area:** 3673.6 µm x 2738.4 µm
- **temperature range:**
 - operational: -30°C to 70°C
 - optimal: 0° to 50°C
- **package/die dimensions:**
 - CSP3: 6945 µm x 6695 µm
 - COB: 6960 µm x 6710 µm

functional block diagram

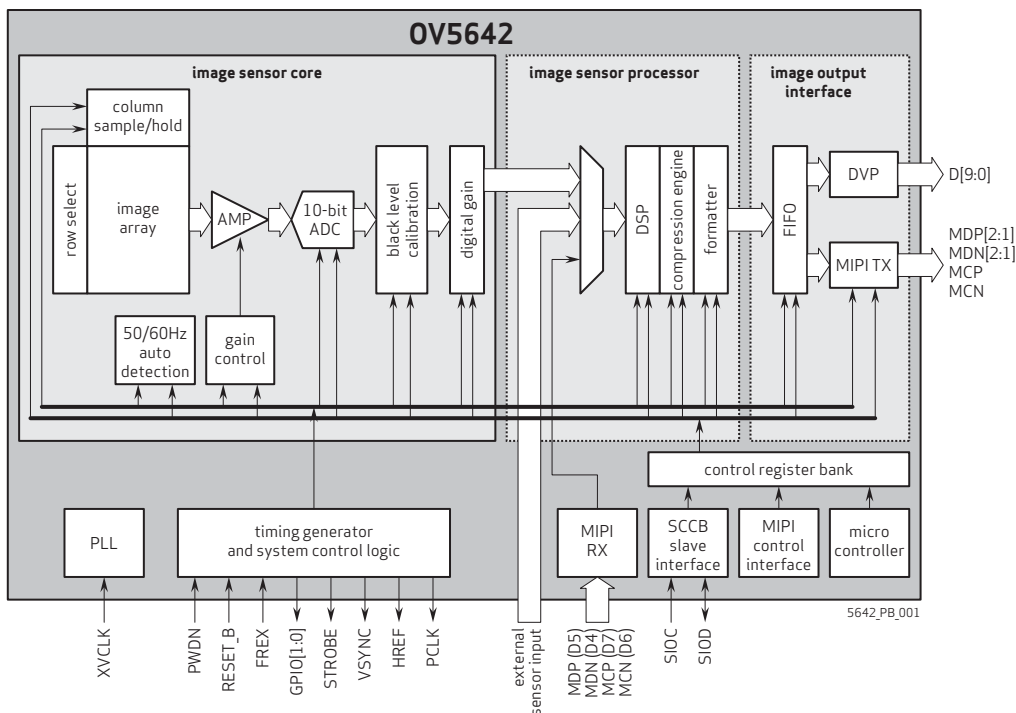

4275 Burton Drive
Santa Clara, CA 95054

tel: +1 408 567 3000
fax: +1 408 567 3001
www.ovt.com

OmniVision reserves the right to make changes to their products or to discontinue any product or service without further notice. OmniVision and OmniPixel are registered trademarks of OmniVision Technologies, Inc. The OmniVision logo, CameraChip and OmniBSI are trademarks of OmniVision Technologies, Inc. All other trademarks are the property of their respective owners.

