



**CHENMKO ENTERPRISE CO.,LTD**

*Lead free devices*

**FAST RECOVERY RECTIFIER**

VOLTAGE RANGE 50 - 1000 Volts CURRENT 1.0 Ampere

**FM101SPT  
THRU  
FM107SPT**

**FEATURES**

- \* Low leakage current
- \* Ideal for surface mounted applications
- \* Metallurgically bonded construction
- \* Plastic package has Underwriters Laboratory Flammability Classification 94V-0
- \* Glass passivated junction
- \* High temperature soldering guaranteed : 260°C/10 seconds at terminals

**MECHANICAL DATA**

**Case:** JEDEC SOD-123S molded plastic  
**Terminals:** Solder plated, solderable per MIL-STD-750, Method 2026  
**Polarity:** Color band denotes cathode end

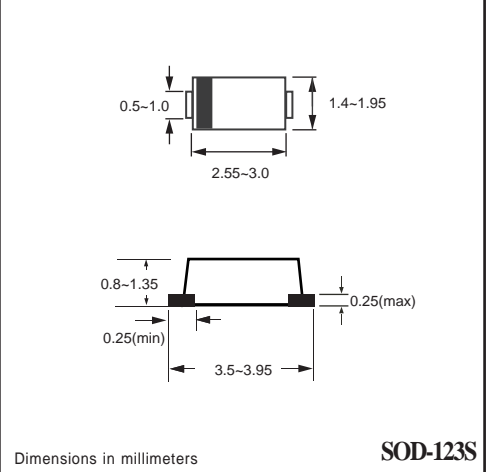

**MAXIMUM RATINGS AND ELECTRICAL CHARACTERISTICS**

Ratings at 25°C ambient temperature unless otherwise specified.  
 Single phase, half wave, 60 Hz, resistive or inductive load.  
 For capacitive load, derate current by 20%.

**MAXIMUM RATINGS** ( At TA = 25°C unless otherwise noted )

RATINGS	SYMBOL	FM101SPT	FM102SPT	FM103SPT	FM104SPT	FM105SPT	FM106SPT	FM107SPT	UNITS
Maximum Recurrent Peak Reverse Voltage	VRRM	50	100	200	400	600	800	1000	Volts
Maximum RMS Voltage	VRMS	35	70	140	280	420	560	700	Volts
Maximum DC Blocking Voltage	Vdc	50	100	200	400	600	800	1000	Volts
Maximum Average Forward Current at TA = 75°C	Io	1.0							Amps
Peak Forward Surge Current 8.3 ms single half sine-wave superimposed on rated load (JEDEC method)	IFSM	30							Amps
Typical Junction Capacitance (Note 1)	CJ	15							pF
Operating and Storage Temperature Range	TJ,STG	-65 to +150							°C

**ELECTRICAL CHARACTERISTICS** ( At TA = 25°C unless otherwise noted )

CHARACTERISTICS	SYMBOL	FM101SPT	FM102SPT	FM103SPT	FM104SPT	FM105SPT	FM106SPT	FM107SPT	UNITS
Maximum Instantaneous Forward Voltage at 1.0 A DC	VF	1.3							Volts
Maximum DC Reverse Current at Rated DC Blocking Voltage at TA = 25°C	IR	5.0							uAmps
Maximum Full Load Reverse Current Average, Full Cycle 0.375" (9.5mm) lead length at TL = 55°C		100							uAmps
Maximum Reverse Recovery Time (Note 2)	trr	150			250		500		nSec

NOTES : 1. Measured at 1.0 MHz and applied reverse voltage of 4.0 volts  
 2. Test Conditions : IF = 0.5 A, IR = -1.0 A, IRR = -0.25 A

# RATING CHARACTERISTIC CURVES ( FM101SPT THRU FM107SPT )

FIG. 1 - TEST CIRCUIT DIAGRAM AND REVERSE RECOVERY TIME CHARACTERISTIC

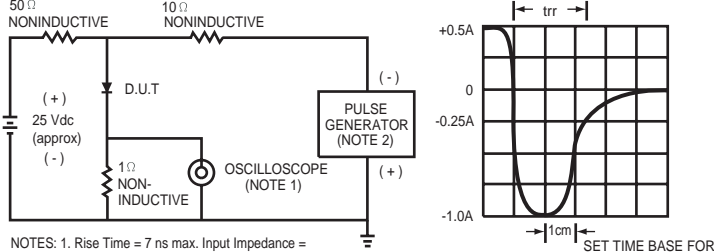

NOTES: 1. Rise Time = 7 ns max. Input Impedance = 1 megohm. 22 pF.  
2. Rise Time = 10 ns max. Source Impedance = 50 ohms.

FIG. 2 - TYPICAL FORWARD CURRENT DERATING CURVE

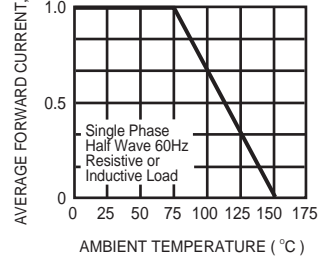

FIG. 3 - TYPICAL REVERSE CHARACTERISTICS

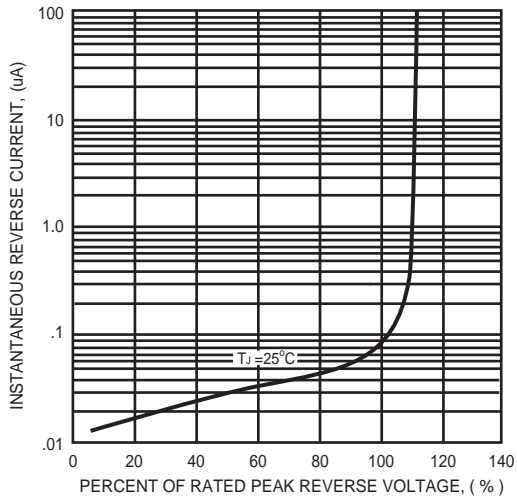

FIG. 4 - TYPICAL INSTANTANEOUS FORWARD CHARACTERISTICS

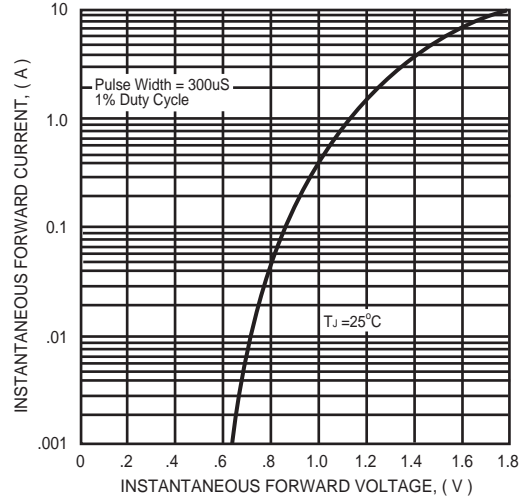

FIG. 5 - MAXIMUM NON-REPETITIVE FORWARD SURGE CURRENT

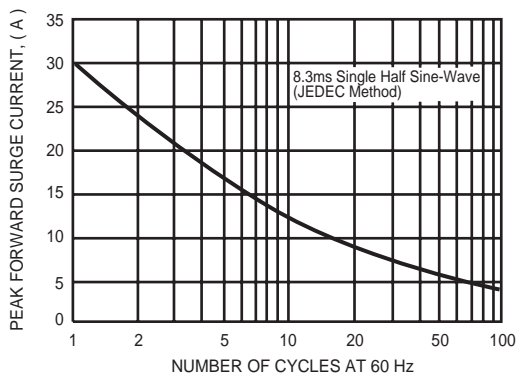

FIG. 6 - TYPICAL JUNCTION CAPACITANCE

