



CHENMKO ENTERPRISE CO.,LTD

CHDTA114WEPT

**SURFACE MOUNT
PNP Digital Silicon Transistor**

VOLTAGE 50 Volts CURRENT 100 mAmpere

Lead free devices

APPLICATION

* Switching circuit, Inverter, Interface circuit, Driver circuit.

FEATURE

- * Small surface mounting type. (SC-75/SOT416)
- * High current gain.
- * Suitable for high packing density.
- * Low collector-emitter saturation.
- * High saturation current capability.
- * Internal isolated PNP transistors in one package.
- * Built in bias resistor(R1=10kΩ, Typ.)

CONSTRUCTION

* One PNP transistors and bias of thin-film resistors in one package.

MARKING

WE1

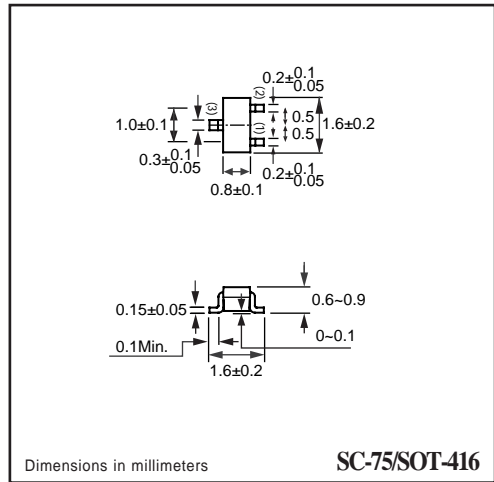
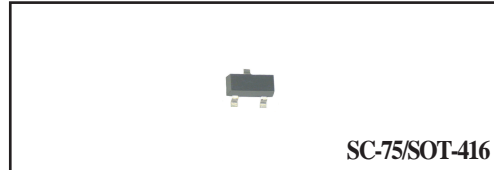

CIRCUIT

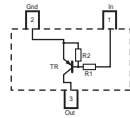

LIMITING VALUES

In accordance with the Absolute Maximum Rating System (IEC 60134).

SYMBOL	PARAMETER	CONDITIONS	MIN.	MAX.	UNIT
V _{CC}	Supply voltage		-	-50	V
V _{IN}	Input voltage		-30	+10	V
I _O	DC Output current		-	-100	mA
I _{C(Max.)}			-	-100	
P _{TOT}	Total power dissipation	T _{amb} ≤ 25 °C, Note 1	-	150	mW
T _{STG}	Storage temperature		-55	+150	°C
T _J	Junction temperature		-	150	°C
R _{θJ-S}	Thermal resistance	junction - soldering point	-	140	°C/W

Note

1. Transistor mounted on an FR4 printed-circuit board.

RATING CHARACTERISTIC (CHDTA114WE)

CHARACTERISTICS

$T_{amb} = 25\text{ }^{\circ}\text{C}$ unless otherwise specified.

SYMBOL	PARAMETER	CONDITIONS	MIN.	TYP.	MAX.	UNIT
$V_{I(off)}$	Input off voltage	$I_o = -100\mu\text{A}; V_{CC} = -50\text{V}$	-0.8	-	-	V
$V_{I(on)}$	Input on voltage	$I_o = -2\text{mA}; V_o = -0.3\text{V}$	-	-	-3.0	V
$V_{O(on)}$	Output voltage	$I_o = -10\text{mA}; I_i = -0.5\text{mA}$	-	-0.1	-0.3	V
I_i	Input current	$V_i = -5\text{V}$	-	-	-0.88	mA
$I_{C(off)}$	Output current	$V_i = 0\text{V}; V_{CC} = -50\text{V}$	-	-	-0.5	μA
h_{FE}	DC current gain	$I_o = -10\text{mA}; V_o = -5.0\text{V}$	24	-	-	
R_1	Input resistor		7	10	13	$\text{K}\Omega$
R_2/R_1	Resistor ratio		0.37	0.47	0.57	
f_T	Transition frequency	$I_E = 5\text{mA}, V_{CE} = -10.0\text{V}$ $f = 100\text{MHz}$	-	250	-	MHz

Note

1. Pulse test: $t_p \leq 300\mu\text{s}; \delta \leq 0.02$.