

AS1747

Low-Voltage, Dual SPDT, Audio Clickless Switch with Negative Rail Capability

1 General Description

The SPDT (single-pole/double-throw) switch AS1747 allows signals below ground to pass through without distortion. This analog switch is ideal for switching audio signals, due to the supply voltage from +1.8V to +5.5V and the low 0.4Ω on-resistance.

This SPDT switch is available in space-saving 10-pin TDFN 3x3 packages and operate over the -40°C to +85°C extended temperature range.

2 Key Features

- Distortion -Free Negative Signal Throughput Down to $V_{CC} - 5.5V$
- Low On-Resistance (R_{ON})
0.4Ω at +2.7V Supply
- 0.25Ω On-Resistance Flatness
- 0.03Ω On-Resistance Matching
- +1.8V to 5.5V Supply Voltage
- -90dB Crosstalk (100kHz)
- -65dB Off-Isolation (100kHz)
- Available in 10-pin TDFN 3x3 Packages

3 Applications

The device is ideal for cell phones, PDAs and hand-held devices, notebook computers and MP3 players.

Figure 1. AS1747 - Typical Operating Circuit

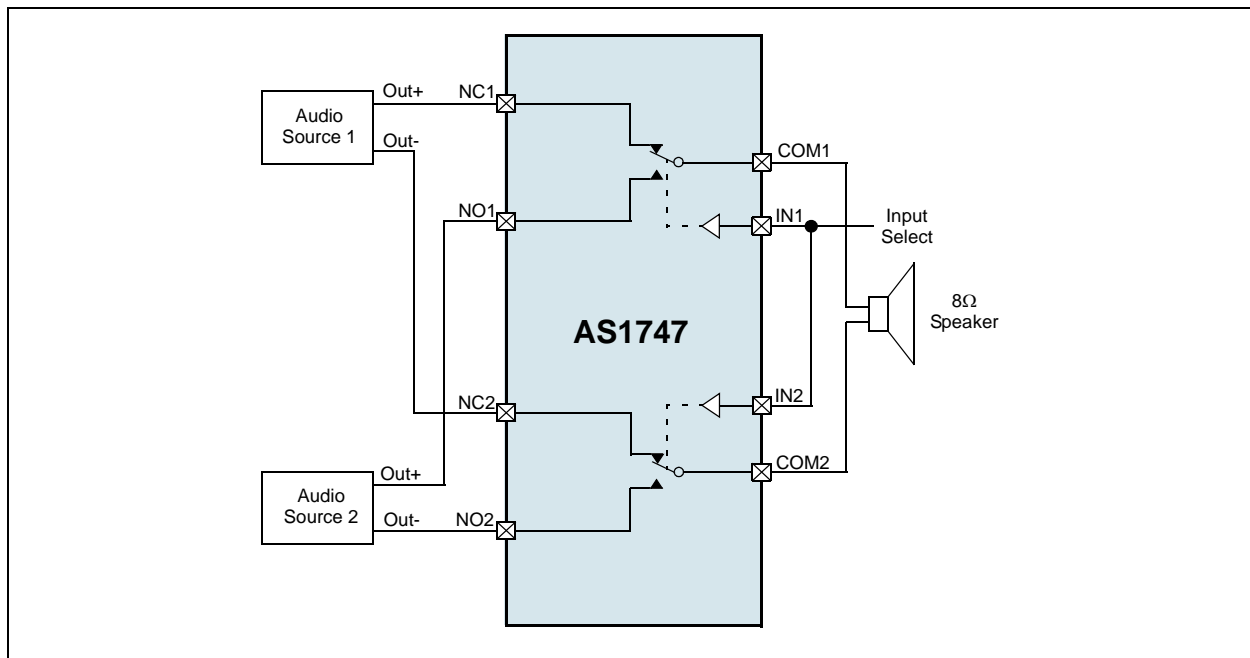

4 Pinout

Pin Assignment

Figure 2. Pin Assignments (Top View)

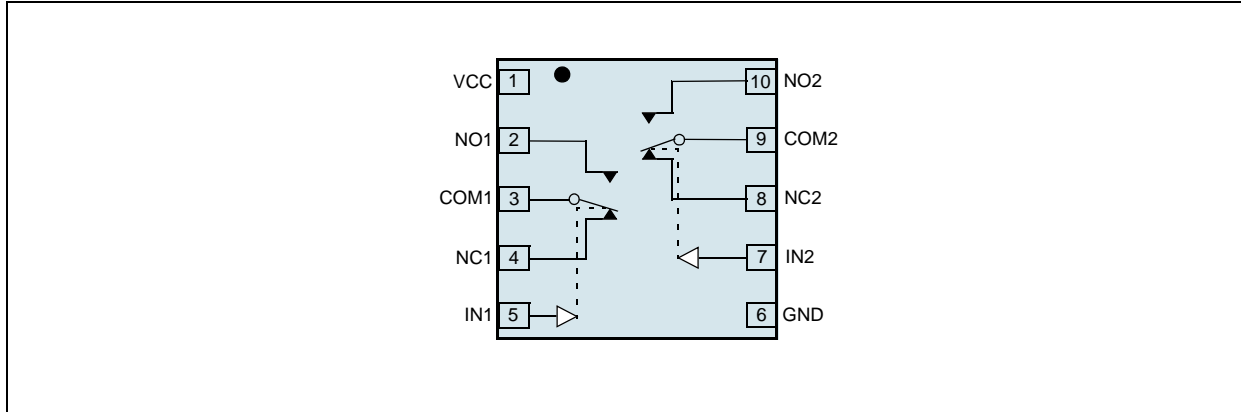

Pin Description

Table 1. Pin Description

Pin Name	TDFN	Description
VCC	1	Positive-Supply Voltage Input
NO1	2	Analog Switch 1 - Normally Open Terminal
COM1	3	Analog Switch 1 - Common Terminal
NC1	4	Analog Switch 1 - Normally Closed Terminal
IN1	5	Digital Control Input for Analog Switch 1. A logic LOW on IN1 connects COM1 to NC1 and a logic HIGH connects COM1 to NO1.
GND	6	Ground
IN2	7	Digital Control Input for Analog Switch 2. A logic LOW on IN2 connects COM2 to NC2 and a logic HIGH connects COM2 to NO2.
NC2	8	Analog Switch 2 - Normally Closed Terminal
COM2	9	Analog Switch 2 - Common Terminal
NO2	10	Analog Switch 2 - Normally Open Terminal

5 Absolute Maximum Ratings

Stresses beyond those listed in [Table 2](#) may cause permanent damage to the device. These are stress ratings only, and functional operation of the device at these or any other conditions beyond those indicated in [Electrical Characteristics on page 4](#) is not implied. Exposure to absolute maximum rating conditions for extended periods may affect device reliability.

Table 2. Absolute Maximum Ratings

Parameter	Min	Max	Units	Comments
V _{CC} , IN _–	-0.3	+6.0	V	
COM _– , NO _– , NC _–	V _{CC} - 6	V _{CC} + 0.3	V	
Closed-Switch Continuous Current COM _– , NO _– , NC _–		±150	mA	
Open-Switch Continuous Current NO _– , NC _–		±30	mA	
Peak Current COM _– , NO _– , NC _– (pulsed at 1ms, 10% duty cycle)		±400	mA	
Continuous Power Dissipation (T_A = +70°C)				
10-Pin TDFN (derate 24.4mW/°C above +70°C)		1951	mW	
ESD	2		kV	HBM MIL-Std. 883E 3015.7 methods
Latchup Immunity	-200	+200	mA	@25°C, JEDEC 78
Operating Temperature Range	-40	+85	°C	
Junction Temperature		+150	°C	
Storage Temperature Range	-65	+150	°C	
Package Body Temperature		+260	°C	The reflow peak soldering temperature (body temperature) specified is in accordance with IPC/JEDEC J-STD-020D "Moisture/Reflow Sensitivity Classification for Non-Hermetic Solid State Surface Mount Devices". The lead finish for Pb-free leaded packages is matte tin (100% Sn).

6 Electrical Characteristics

VCC = +2.7V to +5.5V, TA = -40°C to +85°C, unless otherwise specified. Typical values are at VCC = +3.0V, TA = +25°C, unless otherwise specified.

Table 3. Electrical Characteristics

Symbol	Parameter	Condition	Min	Typ	Max	Unit	
Analog Switch							
VNO_ VNC_ VCOM_	Analog Signal Range		VCC - 5.5		VCC	V	
RON(NC) RON(NO)	On-Resistance	VCC = 2.7V; VNC_ or VNO_ = VCC - 5.5V, -1V, 0V, 1V, 2V, VCC; ICOM_ = 100mA	TA = +25°C	0.4	0.85	Ω	
			TA = TMIN to TMAX		0.95		
ΔRON	On-Resistance Match Between Channels	VCC = 2.7V, VNC_ or VNO_ = 0V, ICOM_ = 100mA	TA = +25°C	0.03	0.1	Ω	
			TA = TMIN to TMAX		0.15		
RFLAT(NC)	On-Resistance Flatness	VCC = 2.7V; VNC_ or VNO_ = -1V, 0V, 1V, 2V, VCC; ICOM_ = 100mA	TA = +25°C	0.25	0.4	Ω	
			TA = TMIN to TMAX		0.45		
INO_(OFF) INC_(OFF)	NO_, NC_ Off-Leakage Current	VCC = 2.7V, switch open; VNC_ or VNO_ = -2.5V, +2.5V; VCOM_ = +2.5V, -2.5V	TA = +25°C	-10	+10	nA	
			TA = TMIN to TMAX	-200	+200		
ICOM_(ON)	COM_ On-Leakage Current	VCC = 2.7V, switch closed; VNC_ or VNO_ = -2.5V, +2.5V; or floating; VCOM_ = -2.5V, +2.5V, or floating	TA = +25°C	-10	+10	nA	
			TA = TMIN to TMAX	-200	+200		
Dynamic Characteristics							
ton	Turn-On Time ¹	VNO_ = 2.5V; for NO_, VIN_ = 0V to VCC; for NC_, VIN_ = VCC to 0V; RL = 300Ω, CL = 35pF, Figure 15	TA = +25°C		200	400	ns
			TA = TMIN to TMAX			400	
toff	Turn-Off Time ¹	VNC_ = 2.5V; for NO_, VIN_ = VCC to 0V; for NC_, VIN_ = 0V to VCC; RL = 300Ω, CL = 35pF, Figure 15	TA = +25°C		100	200	ns
			TA = TMIN to TMAX			200	
td	Break-Before-Make Time Delay	VN_ = 2.5V, for NO_, VIN_ = VCC to 0V; for NC_, VIN_ = 0V to VCC; RL = 300Ω, CL = 35pF, Figure 16			200		ns
Q	Charge Injection	VCOM_ = 0V, RS = 0Ω, CL = 1.0nF, Figure 17			2		pC
VISO	Off-Isolation	VCC = 5V, f = 100kHz, VCOM_ = 1VRMS, RL = 50Ω, CL = 5pF, Figure 18			-65		dB
VCT	Crosstalk	VCC = 5V, f = 100kHz, VCOM_ = 1VRMS, RL = 50Ω, CL = 5pF, Figure 18			-90		dB
PSRR	Power-Supply Rejection Ratio	f = 10kHz, VCOM_ = 1VRMS, RL = 50Ω, CL = 5pF			70		dB
BW	On-Channel-3dB Bandwidth	VCC = 5V, Signal = 0dBm, RL = 50Ω, CL = 5pF, Figure 18			31		MHz
THD	Total Harmonic Distortion	f = 20Hz to 20kHz, VCOM_ = 0.5VP-P, DC Bias = 0, RL = 32Ω			0.01		%
CNO_(Off) CNC_(Off)	NO_, NC_ Off-Capacitance	f = 1MHz, VCOM_ = 0.5VP-P, DC Bias = 0			63		pF

Table 3. Electrical Characteristics (Continued)

Symbol	Parameter	Condition	Min	Typ	Max	Unit
$C_{COM_}(ON)$	COM On-Capacitance	$f = 1\text{MHz}$, $V_{COM_} = 0.5V_{P-P}$, DC Bias = 0		196		pF
Digital I/O (IN₋)						
V_{IH}	Input Logic High Voltage	$V_{CC} = 2.7V$ to $3.6V$	1.4			V
		$V_{CC} = 4.2V$ to $5.5V$	2.0			
V_{IL}	Input Logic Low Voltage	$V_{CC} = 2.7V$ to $3.6V$			0.5	V
		$V_{CC} = 4.2V$ to $5.5V$			0.8	
I_{IN}	Input Leakage Current	$V_{IN_} = 0V$ to V_{CC} , $V_{CC} = 5.5V$	-1		+1	μA
Power Supply						
V_{CC}	Power-Supply Range		1.8		5.5	V
I_{CC}	Supply Current	$V_{CC} = 5.5V$, $V_{IN_} = 0V$ or V_{CC}		0.01	1	μA

1. Guaranteed by design

7 Typical Operating Characteristics

VCC = 3.0V, TA = +25°C (unless otherwise specified).

Figure 3. ON-Resistance vs. VCOM

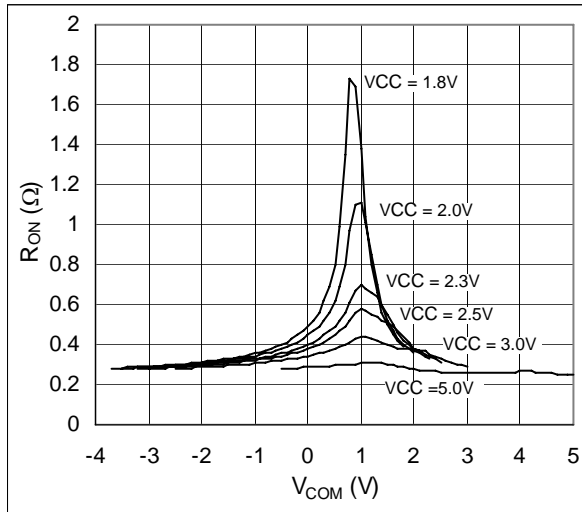

Figure 4. ON Resistance vs. VCOM; VCC=3.0V

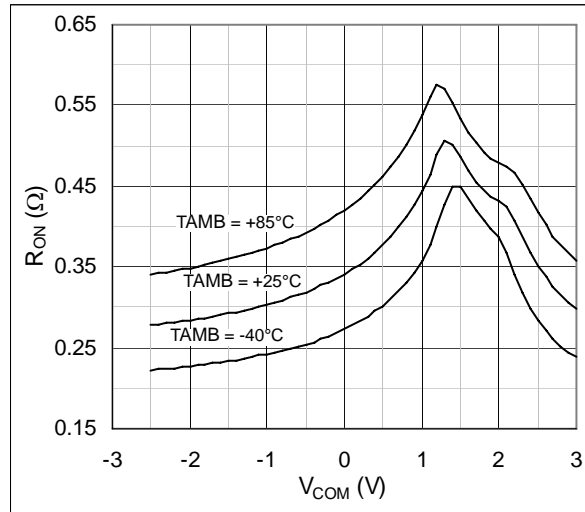

Figure 5. ON Resistance vs. VCOM; VCC=5.0V

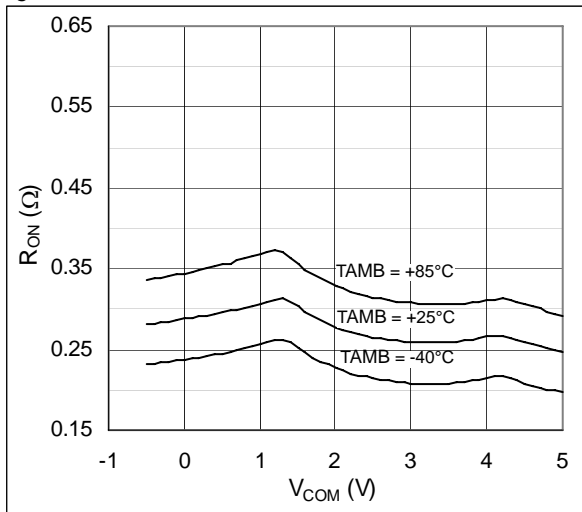

Figure 6. Charge Injection vs. VCOM; CLOAD = 1nF

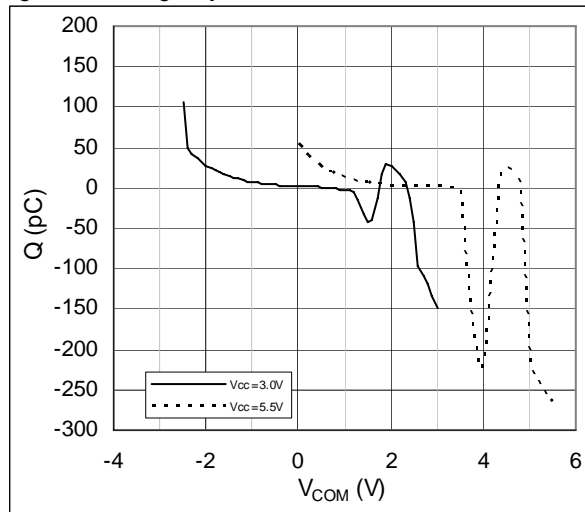

Figure 7. Frequency Response

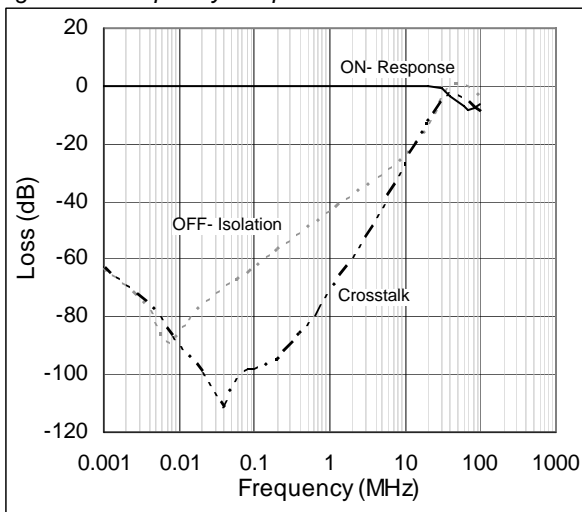

Figure 8. Logic Threshold Voltage vs. VCC

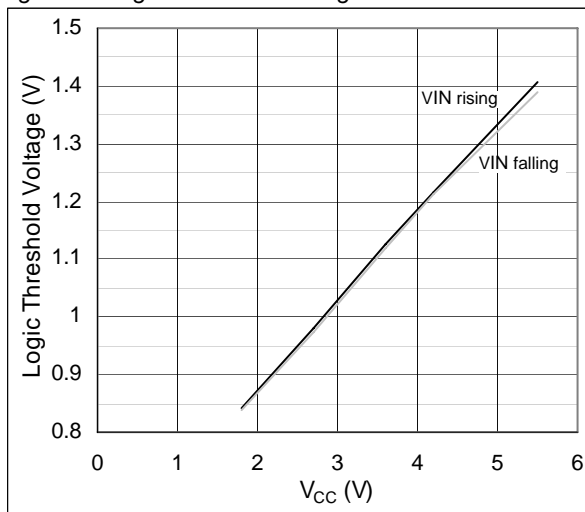

Figure 9. Turn-ON/OFF vs. Temperature; $V_{CC} = 3V$

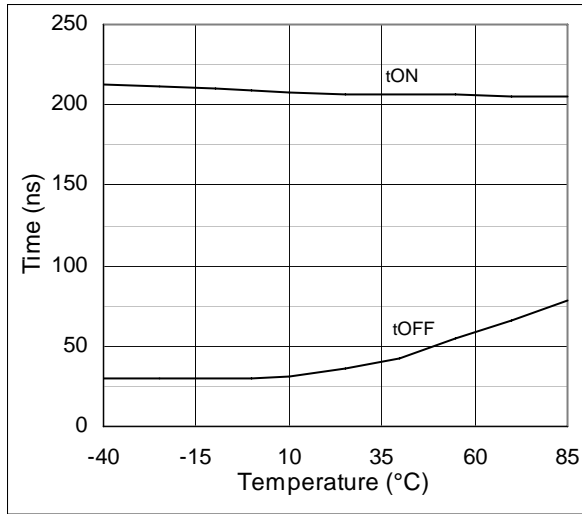

Figure 10. Turn-ON/OFF Times vs. V_{CC}

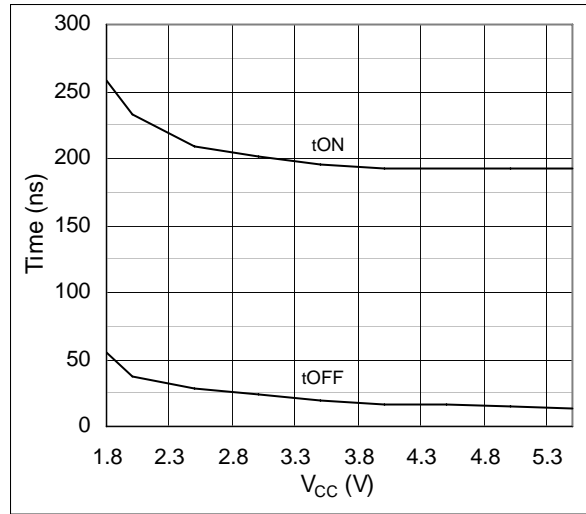

Figure 11. Leakage Current vs. Temperature

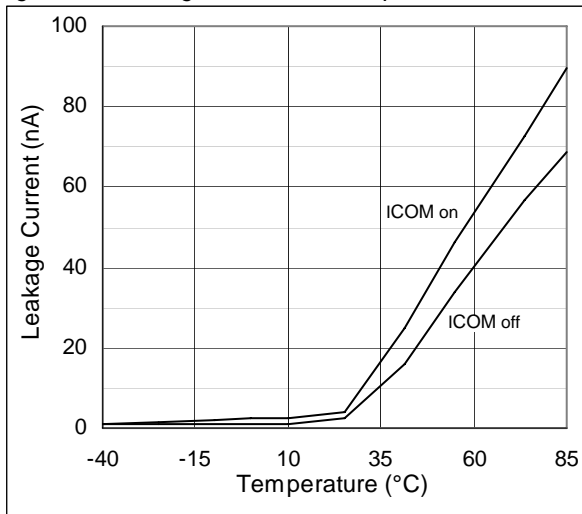

Figure 12. I_{CC} vs. V_{CC}

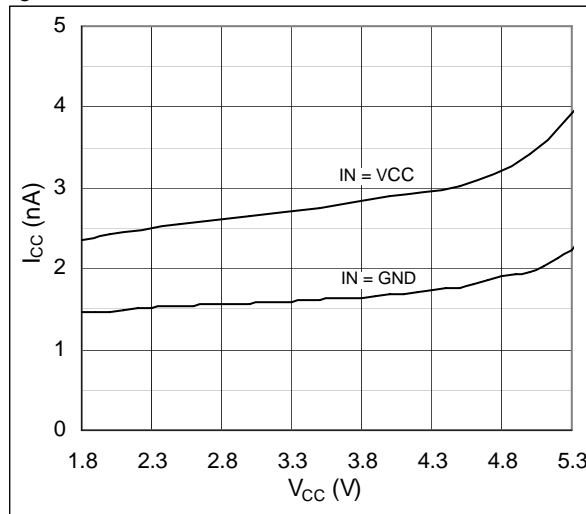

Figure 13. Total Harmonic Distortion vs. Frequency

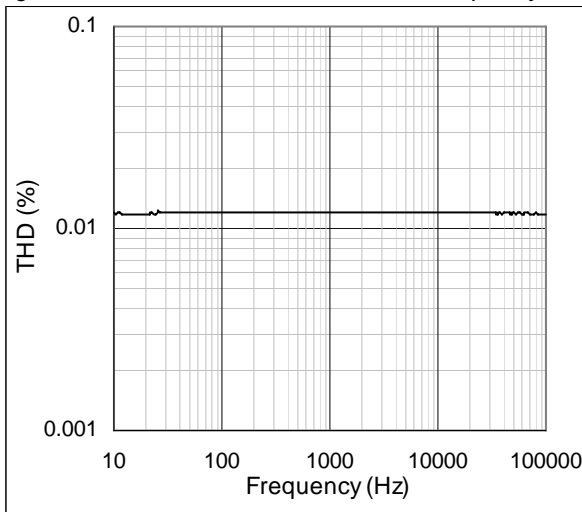
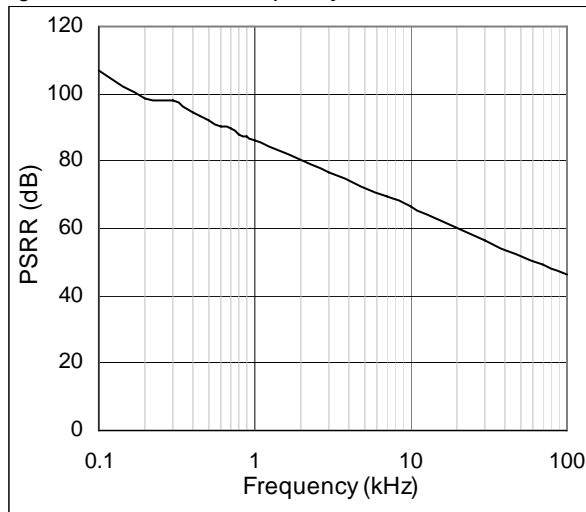

Figure 14. PSRR vs. Frequency



8 Detailed Description

The AS1747 operates from a +1.8V to +5.5V supply and features a negative signal capability that allows signals below ground to pass through without distortion. A break-before-make switching and a low on-resistance is also included in this analog dual SPDT switch. The device is fully specified for a 3.0V application.

9 Application Information

Digital Control Inputs

The logic inputs of the AS1747 accept up to +5.5V independent of the supply voltage. Due to this a mixing of the logic levels in a system is possible. For example, with a +3.3V supply, IN₋ can be driven low to GND and high to +5.5V. For a +1.8V supply voltage, the logic levels are 0.5V (low) and 1.4V (high); for a +5V supply voltage, the logic levels are 0.8V (low) and 2.0V (high).

Analog Signal Levels

The change of the on-resistance of the AS1747 is very little for analog input signals over the whole supply voltage range. The switches are bi-directional, so the NO₋, NC₋, and COM₋ pins can be either inputs or outputs.

The AS1747 pass signals as low as $V_{CC} - 5.5V$, including signals below ground with minimal distortion.

Power-Supply Sequencing and Overvoltage Protection

Caution: Do not exceed the absolute maximum ratings since stresses beyond the listed ratings may cause permanent damage to the device.

Proper power-supply sequencing is recommended for all CMOS devices. Always apply V_{CC} before applying analog signals, especially if the analog signal is not current-limited.

10 Timing Diagrams

Figure 15. Switching Time

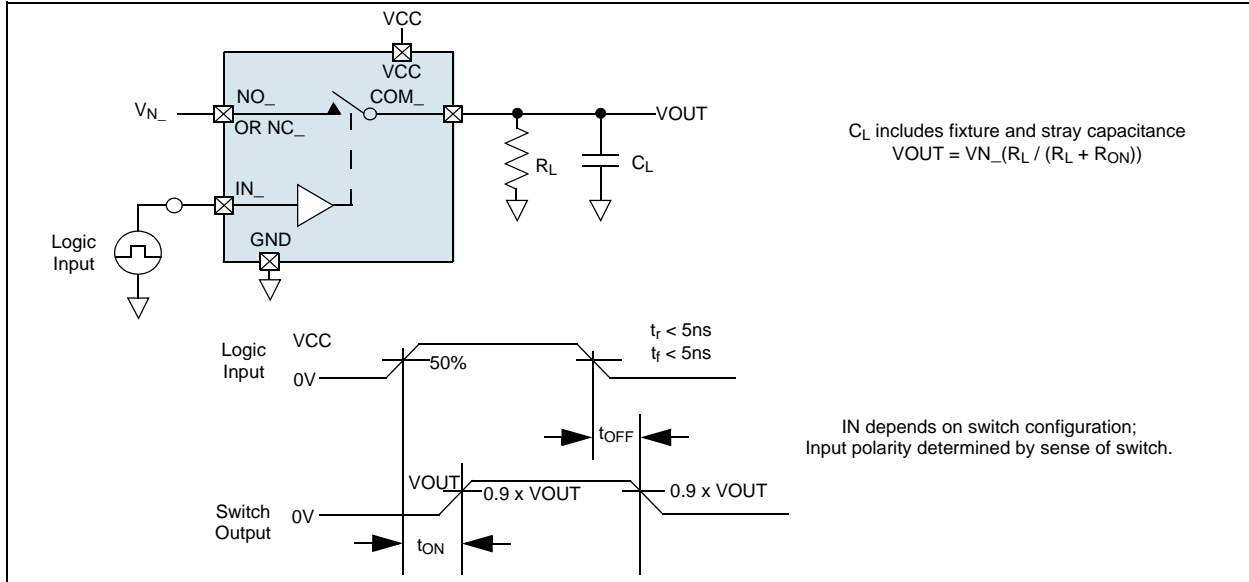

Figure 16. Break-Before-Make Interval

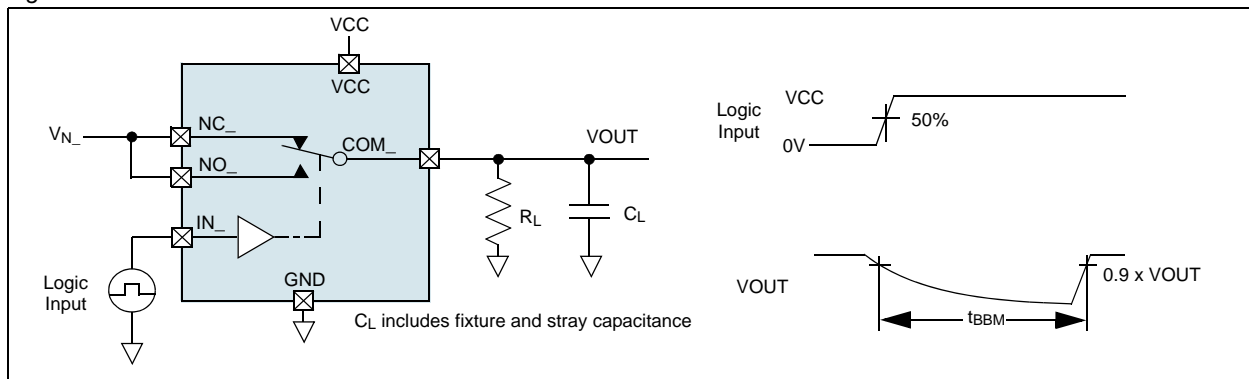

Figure 17. Charge Injection

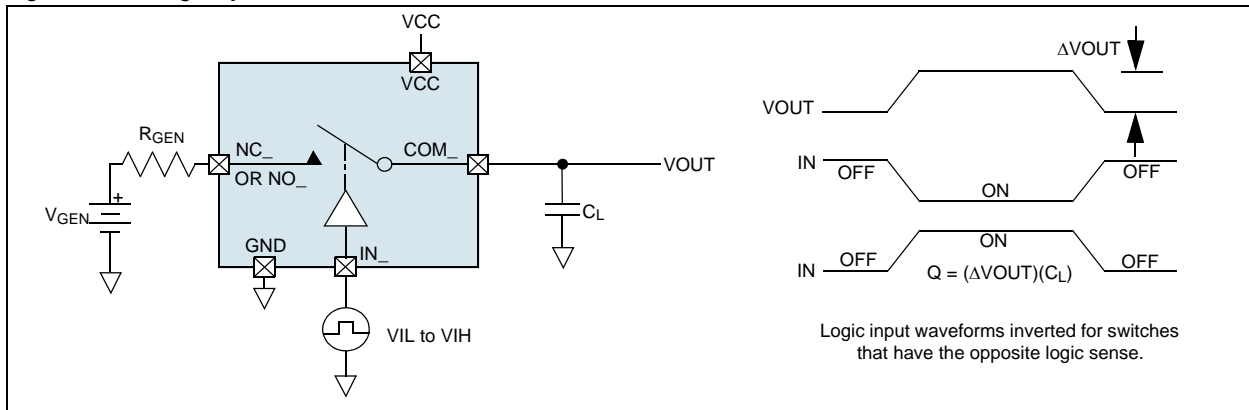
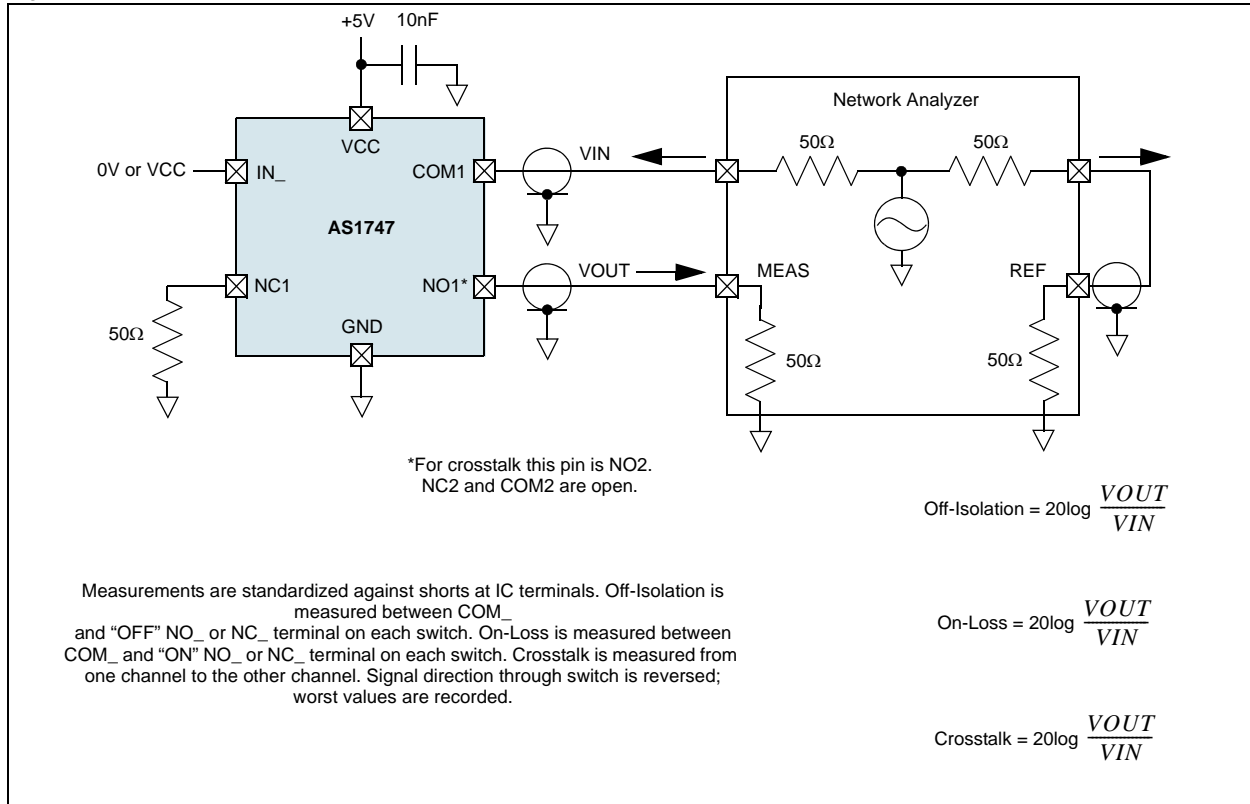

Figure 18. On-Loss, Off-Isolation, and Crosstalk



11 Package Drawings and Markings

The devices are available in 10-pin TDFN 3x3 package.

Figure 19. 10-pin TDFN 3x3 Package Dimensions

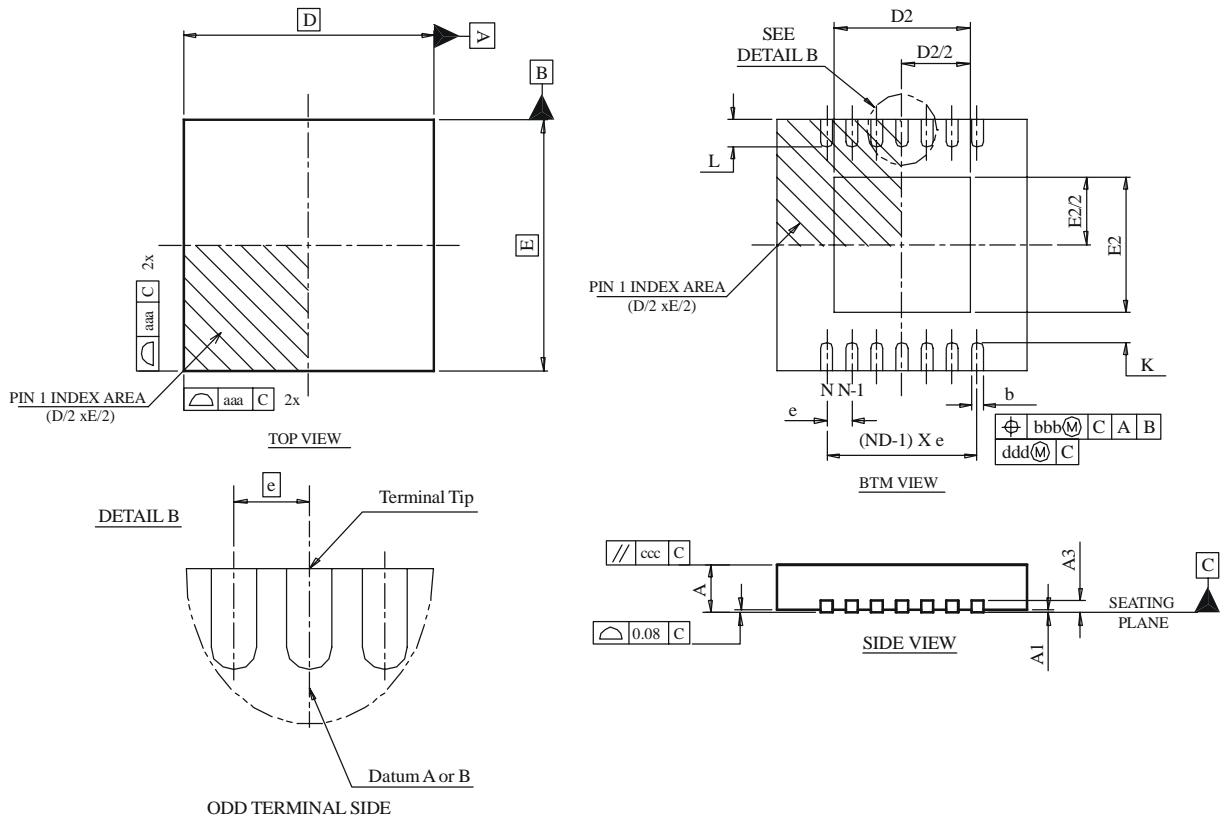

Symbol	Min	Nom	Max
A	0.70	0.75	0.80
A1	0.00	0.02	0.05
A3	0.20 REF		
θ	0°	---	14°
aaa	0.15		
bbb	0.10		
ccc	0.10		
ddd	0.05		
eee	0.08		
ggg	0.10		

Symbol	Min	Nom	Max
D BSC	3.00		
E BSC	3.00		
D2	2.20	---	2.70
E2	1.40	---	1.75
L	0.30	0.40	0.50
K	0.20	---	---
b	0.18	0.25	0.30
e	0.50		
N	10		
ND	5		

Notes:

- Figure 19 is shown for illustration only.
- Dimensioning and tolerancing conform to ASME Y14.5M-1994.
- All dimensions are in millimeters, angle is in degrees.
- N is the total number of terminals.
- ND refers to the maximum number of terminals on D side.

12 Ordering Information

The devices are available as the standard products shown in [Table 4](#).

Table 4. Ordering Information

Model	Description	Delivery Form	Package
AS1747-BTDT	Dual 0.6Ohm SPDT, Audio Clickless Switch with Negative Rail Capability	Tape & Reel	10-pin TDFN (3.0mm x 3.0mm)

Note: All products are RoHS compliant and Pb-free.

Buy our products or get free samples online at ICdirect: <http://www.austriamicrosystems.com/ICdirect>

For further information and requests, please contact us <mailto:sales@austriamicrosystems.com>
or find your local distributor at <http://www.austriamicrosystems.com/distributor>

Copyrights

Copyright © 1997-2009, austriamicrosystems AG, Tobelbaderstrasse 30, 8141 Unterpremstaetten, Austria-Europe. Trademarks Registered ®. All rights reserved. The material herein may not be reproduced, adapted, merged, translated, stored, or used without the prior written consent of the copyright owner.

All products and companies mentioned are trademarks or registered trademarks of their respective companies.

Disclaimer

Devices sold by austriamicrosystems AG are covered by the warranty and patent indemnification provisions appearing in its Term of Sale. austriamicrosystems AG makes no warranty, express, statutory, implied, or by description regarding the information set forth herein or regarding the freedom of the described devices from patent infringement. austriamicrosystems AG reserves the right to change specifications and prices at any time and without notice. Therefore, prior to designing this product into a system, it is necessary to check with austriamicrosystems AG for current information. This product is intended for use in normal commercial applications. Applications requiring extended temperature range, unusual environmental requirements, or high reliability applications, such as military, medical life-support or life-sustaining equipment are specifically not recommended without additional processing by austriamicrosystems AG for each application. For shipments of less than 100 parts the manufacturing flow might show deviations from the standard production flow, such as test flow or test location.

The information furnished here by austriamicrosystems AG is believed to be correct and accurate. However, austriamicrosystems AG shall not be liable to recipient or any third party for any damages, including but not limited to personal injury, property damage, loss of profits, loss of use, interruption of business or indirect, special, incidental or consequential damages, of any kind, in connection with or arising out of the furnishing, performance or use of the technical data herein. No obligation or liability to recipient or any third party shall arise or flow out of austriamicrosystems AG rendering of technical or other services.



Contact Information

Headquarters

austriamicrosystems AG
Tobelbaderstrasse 30
A-8141 Unterpremstaetten, Austria

Tel: +43 (0) 3136 500 0
Fax: +43 (0) 3136 525 01

For Sales Offices, Distributors and Representatives, please visit:

<http://www.austriamicrosystems.com/contact>