



DC COMPONENTS CO., LTD.

DISCRETE SEMICONDUCTORS

2SB772S

TECHNICAL SPECIFICATIONS OF PNP EPITAXIAL PLANAR TRANSISTOR

Description

Designed for use in output stage of 0.75W audio amplifier, voltage regulator, DC-DC converter and relay driver.

Pinning

- 1 = Emitter
- 2 = Collector
- 3 = Base

Absolute Maximum Ratings(T_A=25°C)

Characteristic	Symbol	Rating	Unit
Collector-Base Voltage	V _{CB0}	-40	V
Collector-Emitter Voltage	V _{CEO}	-30	V
Emitter-Base Voltage	V _{EBO}	-5	V
Collector Current	I _C	-3	A
Total Power Dissipation	P _D	750	mW
Junction Temperature	T _J	+150	°C
Storage Temperature	T _{STG}	-55 to +150	°C

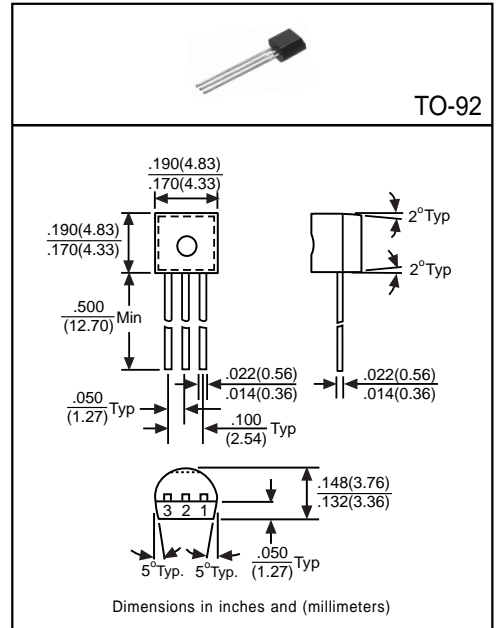

Electrical Characteristics

(Ratings at 25°C ambient temperature unless otherwise specified)

Characteristic	Symbol	Min	Typ	Max	Unit	Test Conditions
Collector-Base Breakdown Voltage	BV _{CB0}	-40	-	-	V	I _C =-100μA
Collector-Emitter Breakdown Voltage	BV _{CEO}	-30	-	-	V	I _C =-1mA
Emitter-Base Breakdown Voltage	BV _{EBO}	-5	-	-	V	I _E =-10μA
Collector Cutoff Current	I _{CB0}	-	-	-1	μA	V _{CB} =-30V
Emitter Cutoff Current	I _{EBO}	-	-	-1	μA	V _{EB} =-3V
Collector-Emitter Saturation Voltage ⁽¹⁾	V _{CE(sat)}	-	-0.3	-0.5	V	I _C =-2A, I _B =-0.2A
Base-Emitter Saturation Voltage ⁽¹⁾	V _{BE(sat)}	-	-1	-2	V	I _C =-2A, I _B =-0.2A
DC Current Gain ⁽¹⁾	h _{FE1}	30	-	-	-	I _C =-20mA, V _{CE} =-2V
	h _{FE2}	100	160	400	-	I _C =-1A, V _{CE} =-2V
Transition Frequency	f _T	-	80	-	MHz	I _C =-0.1A, V _{CE} =-5V
Output Capacitance	C _{ob}	-	55	-	pF	I _E =0, V _{CB} =-10V, f=1MHz

(1) Pulse Test: Pulse Width ≤ 380μs, Duty Cycle ≤ 2%

Classification of h_{FE2}

Rank	Q	P	E
Range	100~200	160~320	200~400