

# QHT-3 Series 90° POWER DIVIDERS / COMBINERS

1 to 400 MHz / 30% Bandwidth Standard / Low Insertion Loss / High Isolation / TO-5 Package

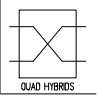

Phasing Diagram - A				
	1	2	3	4
1		ref.	- 90°	Isol.
2	ref.		Isol.	- 90°
3	- 90°	Isol.		ref.
4	Isol.	- 90°	ref.	

## PRINCIPAL SPECIFICATIONS

Model Number	Center Frequency, $f_0$	Usable Bandwidth, MHz
QHT-3-60	60 MHz	51 - 69
QHT-3-***B	1 to 400 MHz	$f_0 \pm 15\%$

For complete Model Number replace \*\*\* with desired Center Frequency,  $f_0$  in MHz.

## GENERAL SPECIFICATIONS

Coupling:	- 3 dB nom.
Isolation:	20 dB min.
Insertion Loss:	0.5 dB max.
Phase Tolerance:	$90^\circ \pm 3^\circ$ max.
Amplitude Balance:	0.5 dB max.
Impedance:	$50 \Omega$ nom.
VSWR:	1.3:1 max.
CW Input:	1 Watt max.
Weight, nominal:	0.1 oz. (2.8 g)
Operating Temperature:	- 55° to +85°C

## Package Outline

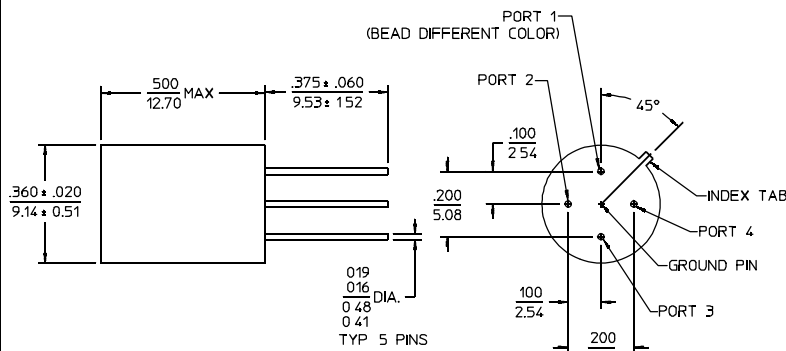

- NOTES:  
 1. Tolerance on 3 place decimals  $\pm 0.10(.25)$  except as noted.  
 2. Dimensions in inches over millimeters.

## Typical QHT-3-30 Performance

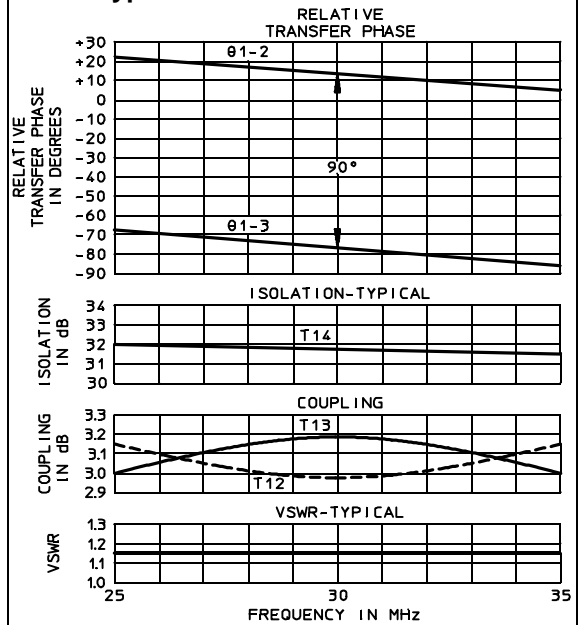

### General Notes:

- The QHT-3 series of two-section hybrids covers 1 to 400 MHz using a special lumped element design to minimize size while maintaining high performance. The TO-5 package used is suitable for aerospace applications where inherent package reliability and hermeticity are essential.
- These units comply with MIL-P-23971 and can be supplied screened for compliance with additional specifications for military and space applications requiring the highest reliability.

20Feb96

For further information contact **MERRIMAC / 41 Fairfield Pl., West Caldwell, NJ, 07006 / 973-575-1300 / FAX 973-575-0531**