

FEATURES

- 12.5 – 15.5 GHz Operating Frequency Range
- 29.5dBm Output Power at 1dB Compression
- 14.0 dB Typical Small Signal Gain
- -41dBc OIMD3 @Each Tone Pout 18.5dBm

APPLICATIONS

- Point-to-point and point-to-multipoint radio
- Military Radar Systems

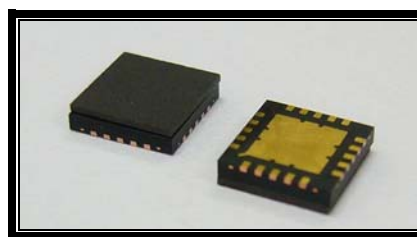

Caution! ESD sensitive device.

ELECTRICAL CHARACTERISTICS (T_a = 25 °C, 50 ohm, VDD=7V, IDQ=750mA)

SYMBOL	PARAMETER/TEST CONDITIONS	MIN	TYP	MAX	UNITS	
F	Operating Frequency Range	EMP214 – Q5	12.5		15.5	GHz
		EMP214H – Q5	13.5		15.5	
		EMP214L – Q5	12.5		14.5	
P1dB	Output Power at 1dB Gain Compression	28.5	29.5		dBm	
G _{ss}	Small Signal Gain	12.0	14.0		dB	
OIMD3	Output 3 rd Order Intermodulation Distortion @Δf=10MHz, Each Tone Pout 18.5dBm I _{ds} =60%±10%I _{dss}		-41	-38	dBc	
Input RL	Input Return Loss		-13	-10	dB	
Output RL	Output Return Loss		-13	-10	dB	
I _{dss}	Saturate Drain Current V _{DS} =3V, V _{GS} =0V	920	1150	1380	mA	
V _{DD}	Power Supply Voltage		7		V	
R _{th}	Thermal Resistance ¹		12		°C/W	
T _b	Operating Base Plate Temperature	-35		+75	°C	

MAXIMUM RATINGS AT 25°C^{2,3}

SYMBOL	CHARACTERISTIC	ABSOLUTE	CONTINUOUS
V _{DS}	Drain to Source Voltage	12 V	8 V
V _{GS}	Gate to Source Voltage	-8 V	-4 V
I _{DD}	Drain Current	I _{dss}	1300mA
I _{GSF}	Forward Gate Current	114mA	19mA
P _{IN}	Input Power	27dBm	@ 3dB compression
T _{CH}	Channel Temperature	175°C	150°C
T _{STG}	Storage Temperature	-65/175°C	-65/150°C
P _T	Total Power Dissipation	12.4W	10.4W

1. Measured result when used with Excelics recommended evaluation board.

2. Operating the device beyond any of the above rating may result in permanent damage.

3. Bias conditions must also satisfy the following equation $V_{DS} \cdot I_{DS} < (T_{CH} - T_{HS})/R_{TH}$; where T_{HS} = Base Plate temperature

Specifications are subject to change without notice.

CHIP OUTLINE AND PIN ASSIGNMENT

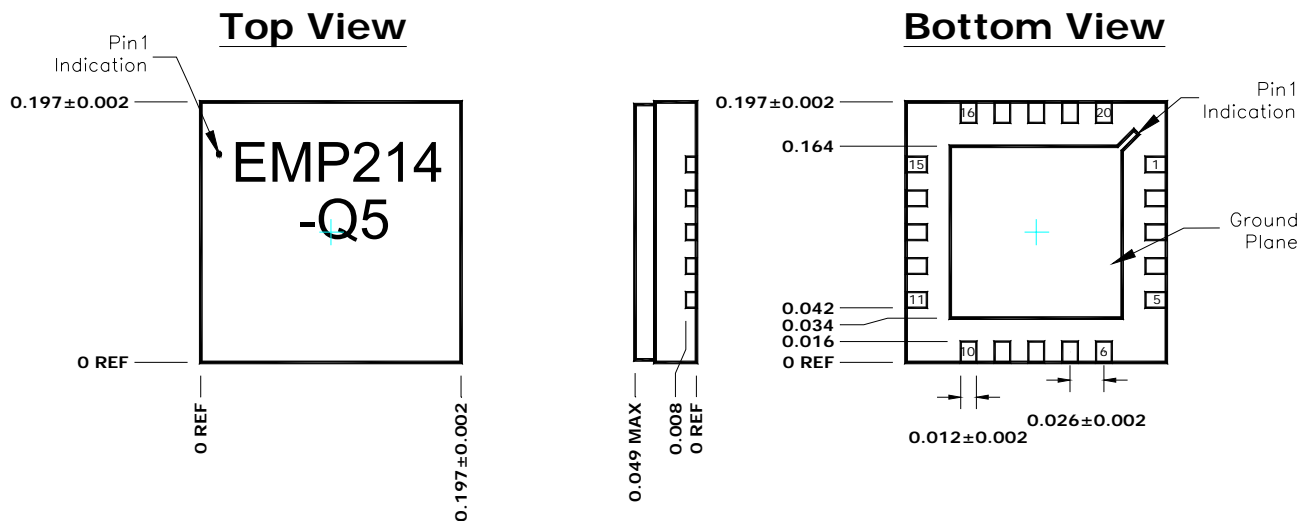

Additional Notes:

- 1) Ground Plane must be soldered to PCB RF ground
- 2) All dimensions are in inches
- 3) Refer to Excelics application notes on QFNs for further guidelines
- 4) Pin Assignment:

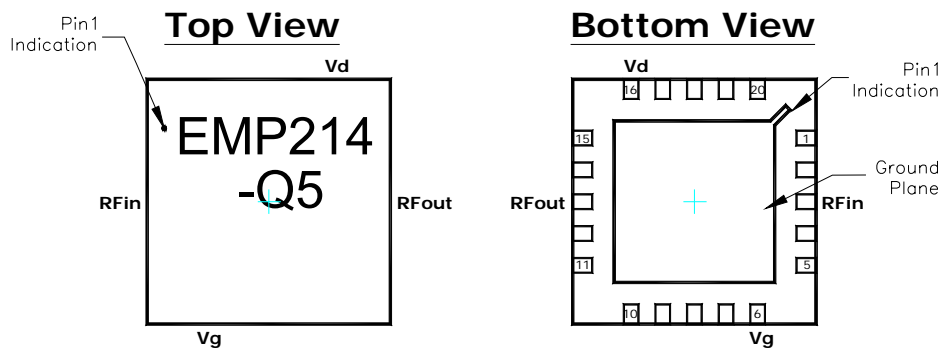

Pin	Assignment
1, 2, 4, 5	NC
3	RF _{in}
6	V _g
7, 8, 9, 10, 11, 12, 14, 15	NC
13	RF _{out}
16	V _d
17, 18, 19, 20	NC

Specifications are subject to change without notice.

Typical Performance:

1. Small-Signal Parameters (@Vds = 7V, Ids = 800mA)

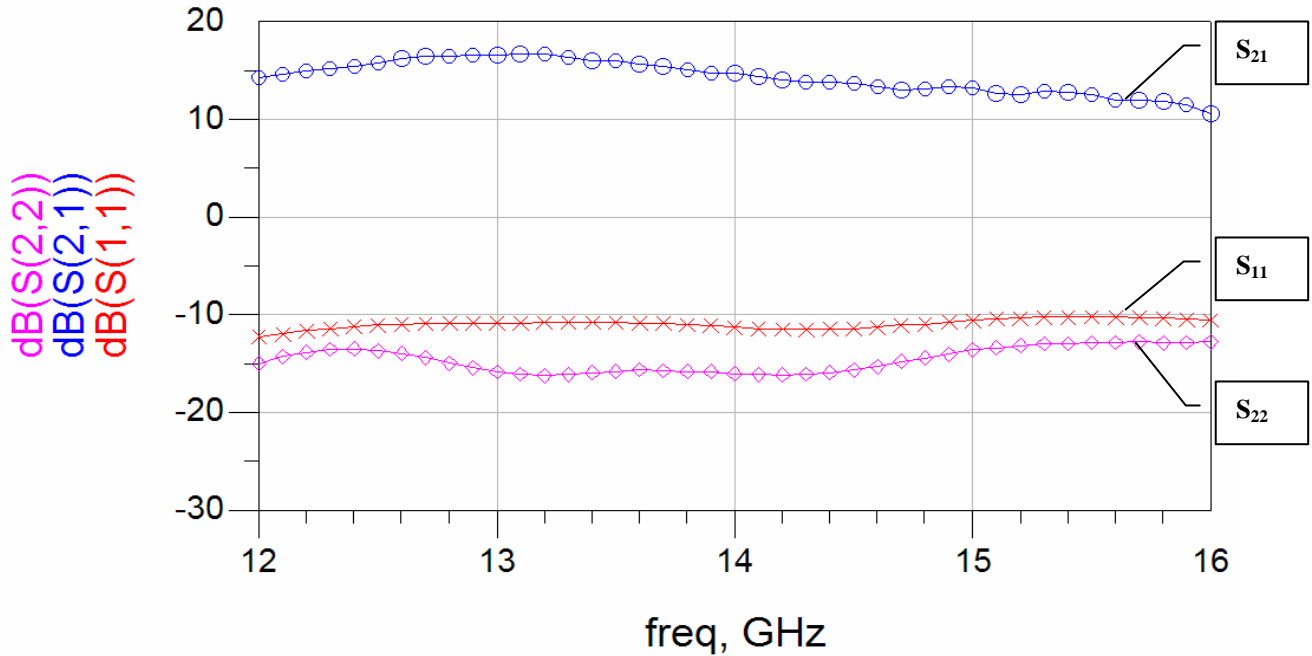

2. P1-dB & G1-dB (@Vds = 7V, Ids = 800mA)

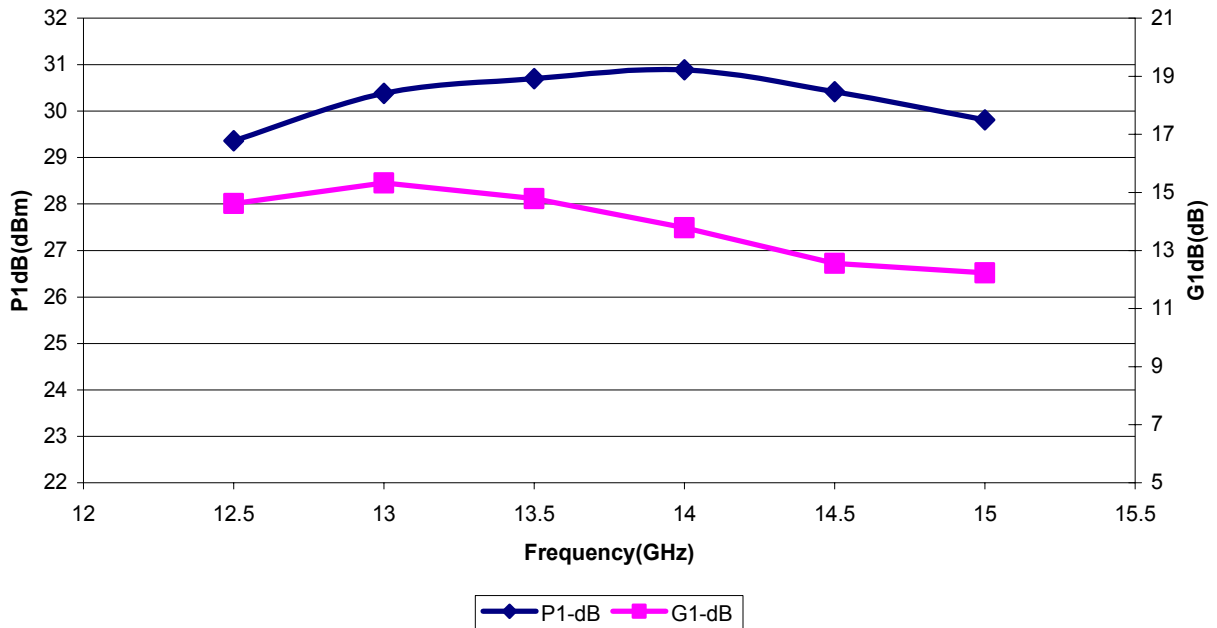

UPDATED 04/24/2008

12.50 – 15.50 GHz Surface-Mounted PA

3. OIMD3 (@Vds = 7V, Ids = 800mA, f = 14.5GHz, Δf = 10MHz)

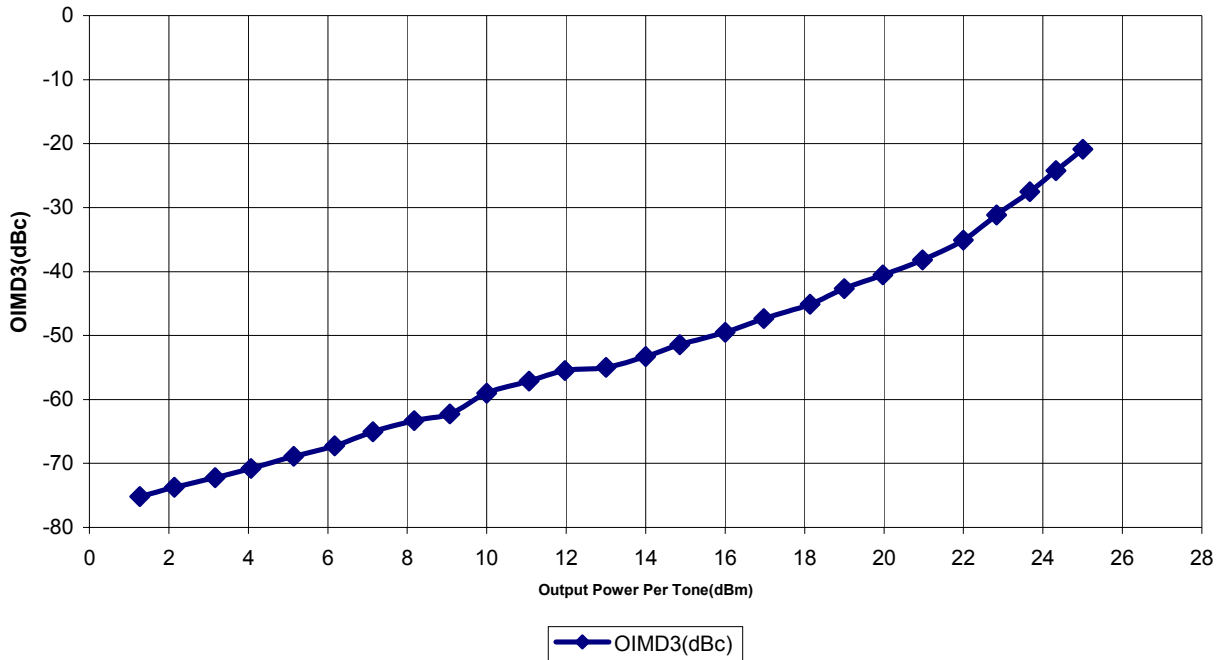

Specifications are subject to change without notice.

Recommended Circuit Schematic:

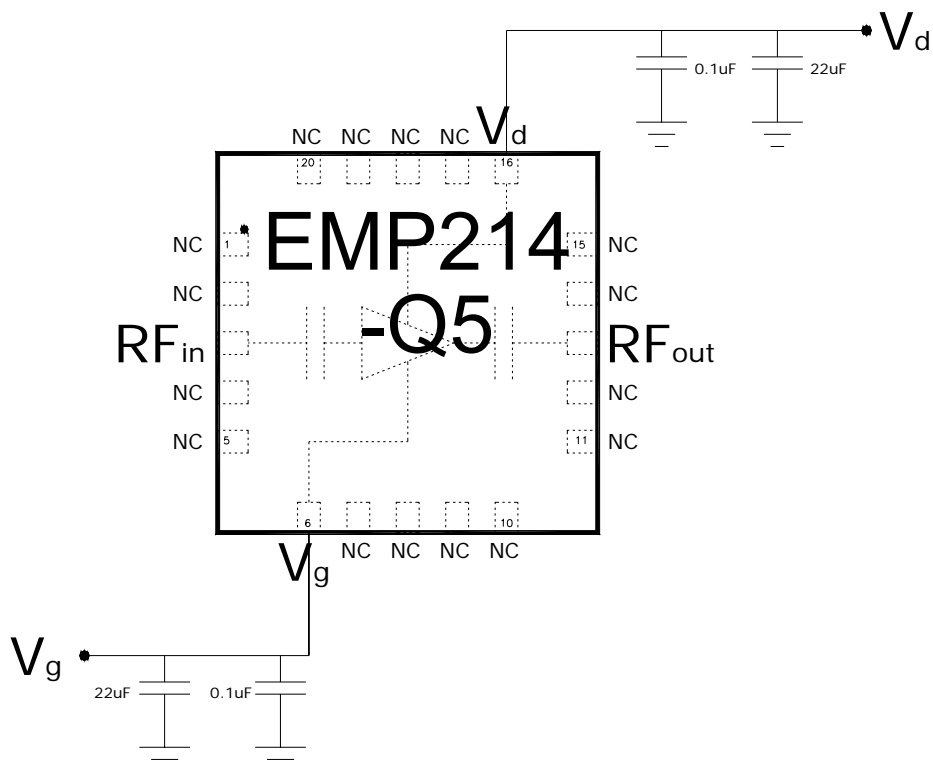

Notes:

- 1) External bypass capacitors should be placed as close to the package as possible.
- 2) Dual biasing sequence required:
 - a. Turn-on Sequence: Apply $V_g = -2.5V$, followed by $V_d = 7V$, lastly increase V_g until required I_{dq}
 - b. Turn-off Sequence: Turn off V_d , followed by V_g
- 3) Demonstration board available upon request.



Specifications are subject to change without notice.