



LBN08008 MHz SAW Filter Electrical Characteristic

Specifications

Parameter	Unit	Minimum	Typical	Maximum
Center Frequency	MHz	79.875	80	80.125
Insertion Loss	dB		28.20	29.5
2 dB Bandwidth	MHz	25	25.08	
20 dB Bandwidth	MHz		25.78	25.80
30 dB Bandwidth	MHz		25.94	26.2
40 dB Bandwidth	MHz		26.05	26.6
Passband variation	dB		1.5	2.0
Absolute Delay	usec		3.15	4.5
Ultimate Rejection	dB	45	50	55
Substrate Material		YZ LN		
Ambient Temperature	°C	25		
Package Size	DIP3512 (35.0x12.7x5.2mm ³)			

Typical Performance

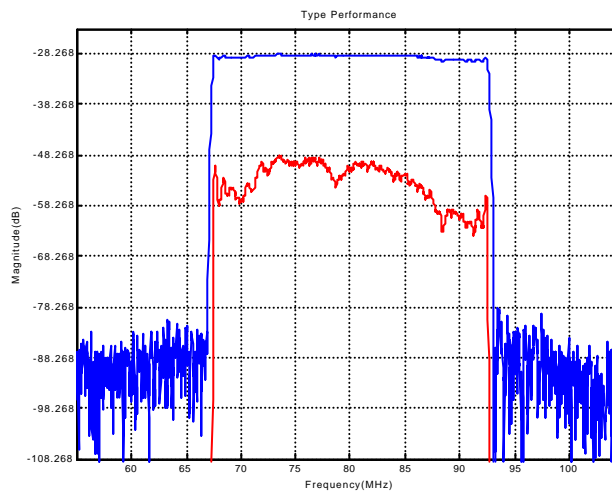

Package Outline

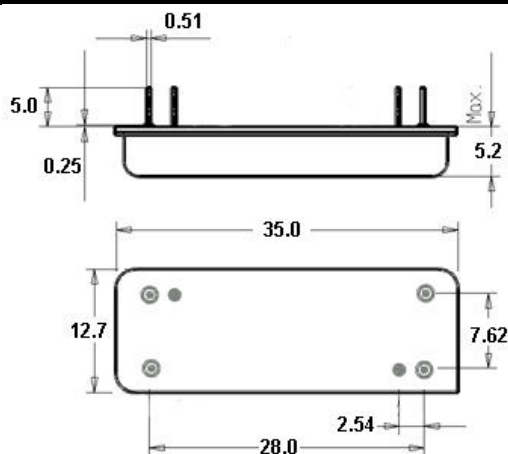

Matching Configuration

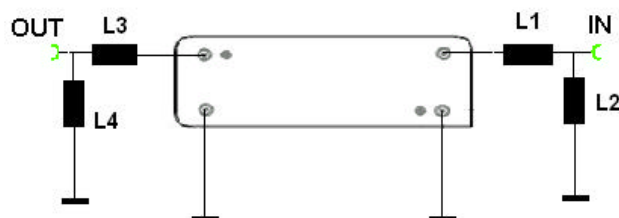

L1=39nH L2=82nH
 L3=68nH L4=100nH

Source/Load Impedance = 50 ohm