

IMP-2 Series

IMAGE REJECT MIXERS

10 to 3000 MHz / Image Rejection up to 30 dB / Internal Summing Quadrature / Hi-Rel Package

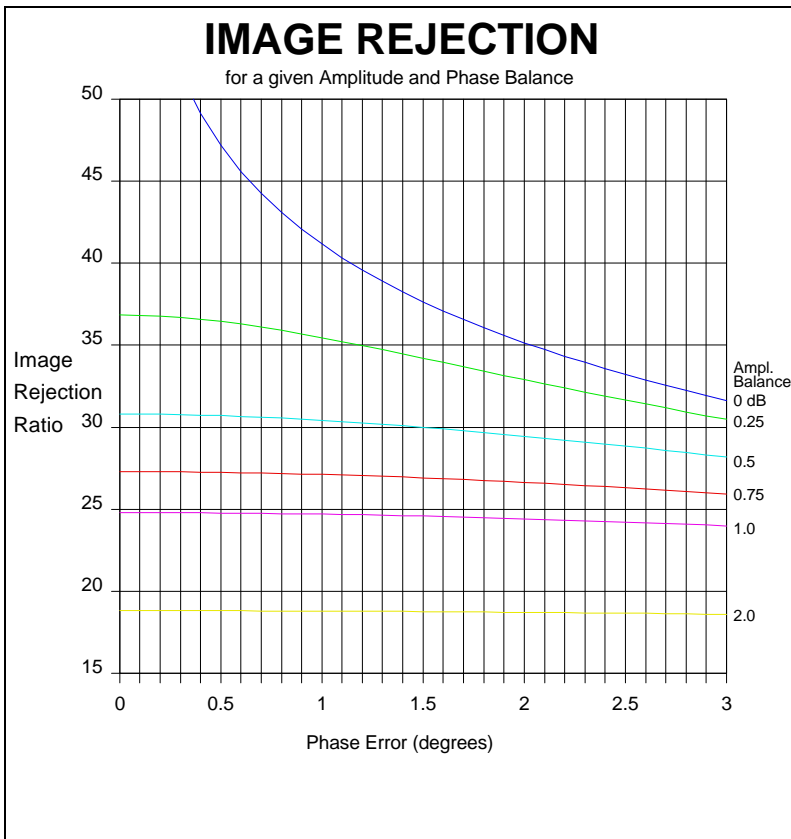
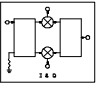
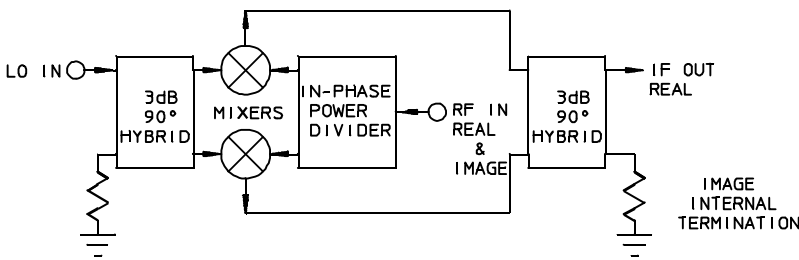

PRINCIPAL SPECIFICATIONS

Model Number	LO Center Freq., f_0 , MHz	Bandwidth MHz	Outline Style
IMP-2S-***	10 - 1000	10% of f_0	S
IMP-2U-***	1000 - 3000	10% of f_0	U

Model Numbering Note

A complete model number shall be assigned upon establishment of a full performance specification by the factory in conjunction with the customer. The model number shall include an indicator of the center frequency (f_0) and a special slash number to distinguish it from related units. The format of model numbers is as above where *** = f_0 .

GENERAL SPECIFICATIONS

(when used as a Down Converter)

RF/LO Input Characteristics

Impedance:	50 Ω nom.
VSWR:	1.5:1 max.
RF Power Level:	0 dBm nom.
LO Power Level:	+10 dBm nom.
IF Bandwidth:	up to an octave
RF Bandwidth:	up to an octave
LO Bandwidth:	10%

Output Characteristics

Conversion Loss:	9 dB max.
Image Rejection:	25 dB min. (For bandwidth as above)
Operating Temp:	-55° to +85°C

General Notes:

- Image Reject Mixers are integrated networks composed of an in-phase power divider, two double balanced mixers and two 90° quadrature hybrids. Their principal function is the separation of two signals closely spaced in the frequency domain in, for example, a receiver's IF stage.
- An *image* is a spurious signal occurring in a receiver's IF stage together with the *real* signal. Both result from the mixing process. Normally, a passband filter selects the real signal while rejecting the image. However, when the frequency difference between the real and image signals is relatively small, conventional bandpass filters are generally inadequate.
- In an Image Reject Mixer, the image is separated from the real signal by vector subtraction. The resulting attenuation of the image is usually expressed as the "Image Rejection Ratio" in dB. (See graph).
- Several factors affect attainable image rejection. For example, image rejection is a function of bandwidth, the phase and amplitude balances of the individual components chosen, mixer sensitivity and VSWR interaction among other factors. The graph allows estimating attainable image rejection under the variables of phase error and amplitude imbalance.
- Merrimac offers a wide range of Image Reject Mixers for numerous applications. All units are designed and built in accord with applicable specifications. Designers are invited to work closely with Merrimac engineers to insure best results.
- All Merrimac Image Reject Mixers comply with applicable sections of MIL-M-28837 and may be supplied screened for compliance with additional specifications for military and space applications requiring the highest reliability.

23Feb96

IMP-2 Series

IMAGE REJECT MIXERS

10 to 3000 MHz / Image Rejection up to 30 dB / Internal Summing Quadrature / Hi-Rel Package

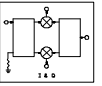

S-Package Outline

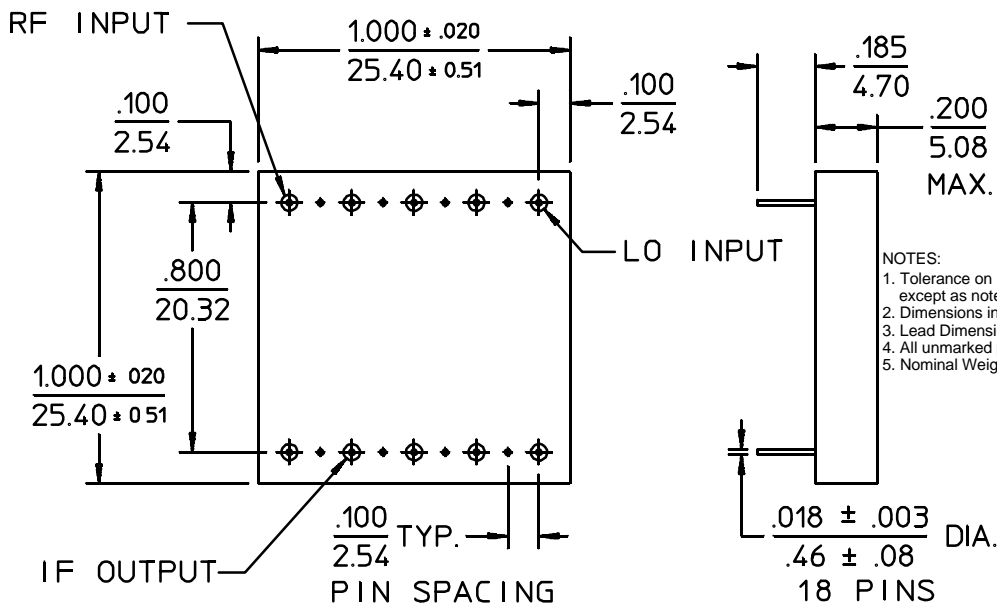

U-Package Outline

- NOTES:
1. Tolerance on 3 place decimals $\pm .010(.25)$ except as noted.
 2. Dimensions in inches over millimeters.
 3. Dimensions marked with * apply only at body.
 4. All unmarked pins are case ground.
 5. Nominal Weight: 0.55 oz. (15.4 g).

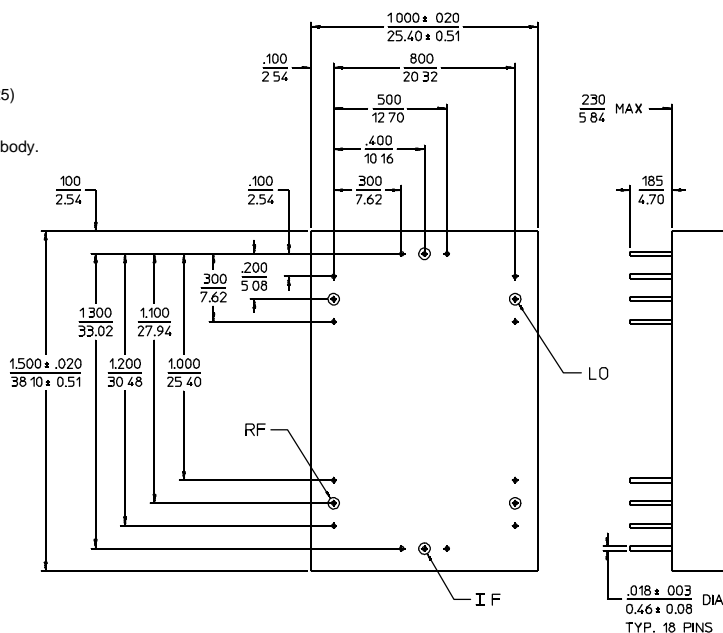

13Feb96