

DISPLAYTRONIC

XIAMEN ZETTLER ELECTRONICS CO., LTD.

SPECIFICATIONS FOR LIQUID CRYSTAL DISPLAY

AGM1612B-FLW-FBW GRAPHIC MODULE VER2.0

CUSTOMER APPROVAL			
※ PART NO. : _____			
APPROVAL		COMPANY CHOP	
CUSTOMER COMMENTS			

DISPLAYTRONIC ENGINEERING APPROVAL		
DESIGN BY	CHECKED BY	APPROVED BY

AGM1612B-FLW-FBW GRAPHIC MODULE VER2.0

REVISION RECORD

REVISION	REVISION DATE	PAGE	CONTENTS
VER1.0	2008-02-03		FIRST ISSUE
VER2.0	2008-02-21		

※ CONTENTS

- 1.0 MECHANICAL DIAGRAM
- 2.0 MECHANICAL SPECS
- 3.0 ABSOLUTE MAXIMUM RATINGS
- 4.0 ELECTRICAL CHARACTERISTICS
- 5.0 OPTICAL CHARACTERISTICS
- 6.0 BLOCK DIAGRAM
- 7.0 PIN ASSIGNMENT
- 8.0 APPLICATION
- 9.0 TIMING CHARACTERISTICS
- 10.0 RELIABILITY TEST
- 11.0 DISPLAY CONTROL INSTRUCTION
- 12.0 PRECAUTION FOR USING LCM

1.0 MECHANICAL DIAGRAM

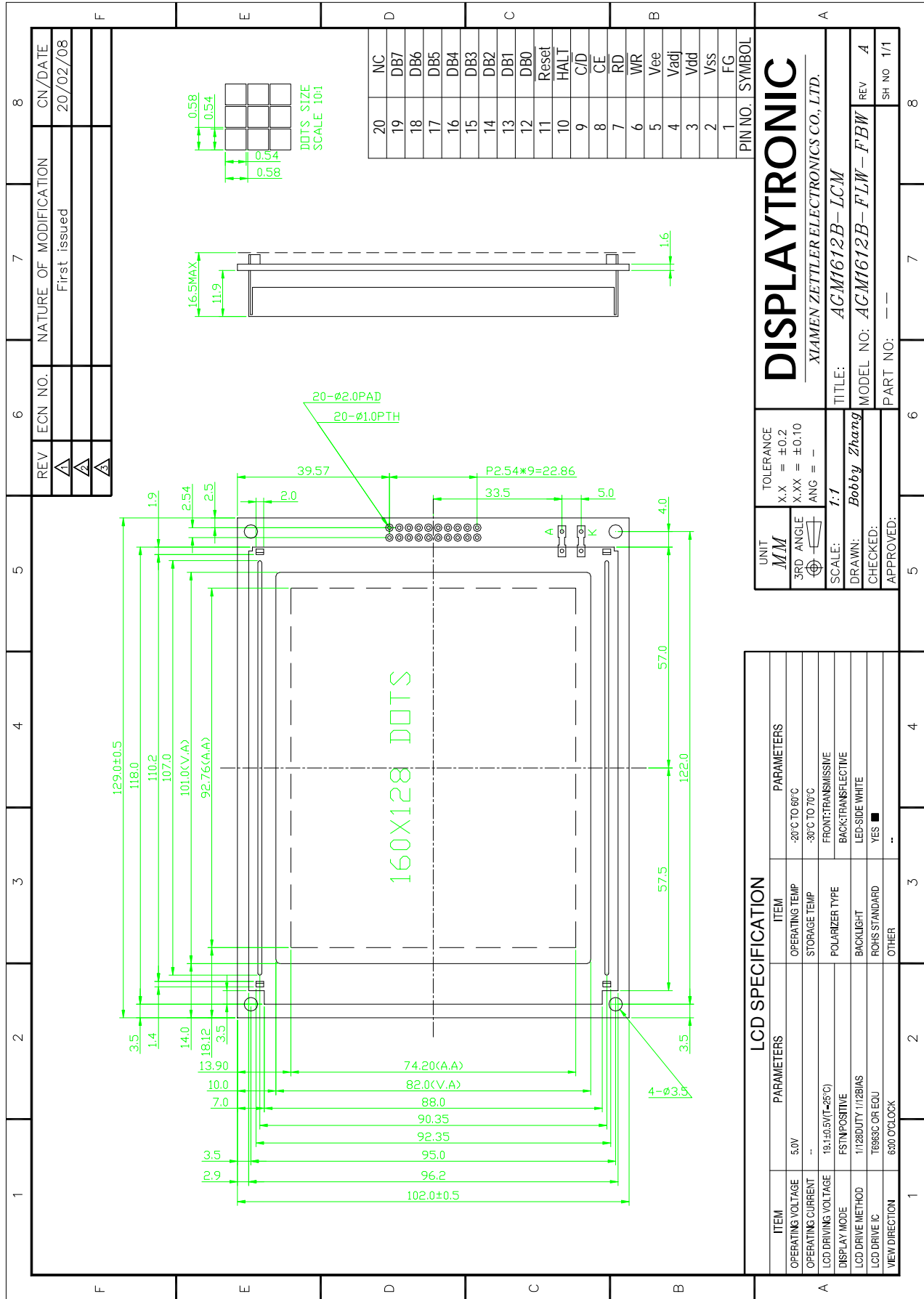

2.0 MECHANICAL SPECS

1. Overall Module Size	129.0mm(W) x 102.0mm(H) x max 16.5mm(D) for LED backlight version
2. Dot Size	0.54mm(W) x 0.54mm(H)
3. Dot Pitch	0.58mm(W) x 0.58mm(H)
4. Duty	1/128
5. Controller IC	T6963C
6. LC Fluid Options	FSTN
7. Polarizer Options	TRANSFLECTIVE
8. Backlight Options	WHITE SIDE LED
9. Temperature Range Options	Wide (-20°C ~ 60°C)

3.0 ABSOLUTE MAXIMUM RATINGS

Item	Symbol	Min	Typ	Max	Unit
Operating temperature (Wide temperature)	Top	-20	-	60	°C
Storage temperature (Wide temperature)	Tst	-30	-	70	°C
Input voltage	Vin	-0.3	-	Vdd+0.3	V
Supply voltage for logic	Vdd- Vss	-0.3	-	7.0	V
Supply voltage for LCD drive	Vdd- VLCD	6	-	28	V

4.0 ELECTRICAL CHARACTERISTICS

Item	Symbol	Condition	Min	Typ	Max	Unit
Input voltage (high)	Vih	H level	Vdd-2.2	-	Vdd	V
Input voltage (low)	Vil	L level	0	-	0.8	V
Recommended LC Driving Voltage	Vdd -VLCD	-20°C	-	-	-	V
		0°C	-	-	-	
		25°C	-	19.1	-	
		70°C	-	-	-	
Power Supply Current	Idd	Vdd=5.0V	-	24.5	35.0	mA
LED Power Supply Voltage	Vop=(VA-VK)	-	2.9	3.2	3.5	V
LED Power Supply Current	Iled(WHITE)	RL=0 Ω	-	135	-	mA

5.0 OPTICAL CHARACTERISTICS

Mode \ Item		Cr (Contrast Ratio)		θ (Viewing Angle)		ϕ (Viewing Angle)	
		25°C		25°C		25°C	
		MIN.	TYP.	MIN	TYP.	MIN	TYP.
R	A	2.8	3.05	80°	85°	-	35°
	B	7.10	7.70	80°	85°	-	35°
	C	-	-	-	-	-	-
S	A	2.49	2.99	80°	85°	-	35°
	B	7.05	7.55	80°	85°	-	35°
	C	-	-	-	-	-	-

Note:

- R: Reflective S: Transflective
- A: STN Gray
- B: STN Yellow
- C: FSTN

At: $\phi = 0^\circ, \theta = 0^\circ$

Item	Symbol	Condition	Min	Typ	Max	Unit
Response time (rise)	Tr	25 °C	-	150	250	ms
Response time (fall)	Tf	25°C	-	150	250	ms

6.0 BLOCK DIAGRAM

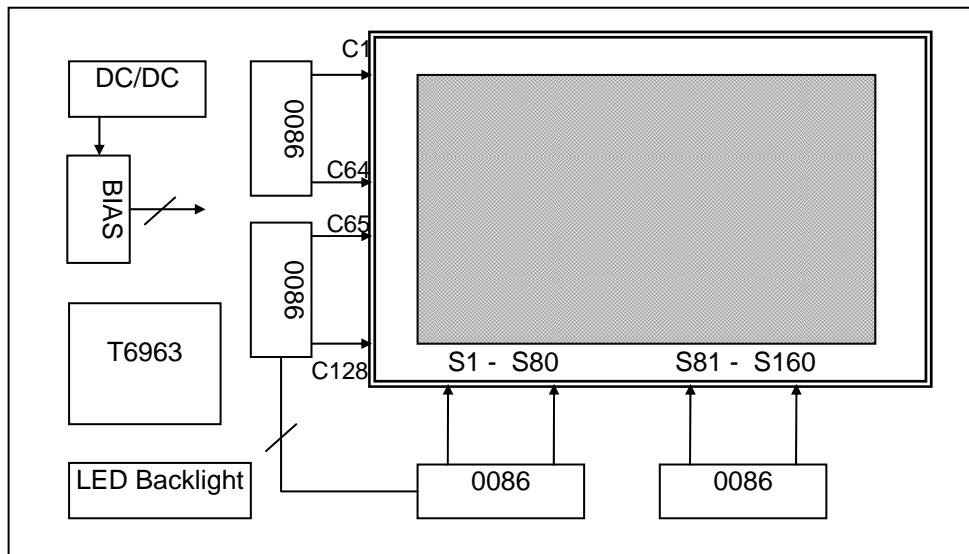

7.0 PIN ASSIGNMENT

Pin No.	Symbol	Function
1	FG	Frame Ground
2	VSS	Ground
3	VDD	+5V
4	VADJ	Power supply for LCD driving
5	VEE	NEGATIVE VOLTAGE SUPPLY
6	/WR	WRITE SIGNAL
7	/RD	READ SIGNAL
8	/CE	Chip Enable
9	C/D	Command/Data
10	/HALT	
11	/RESET	Reset
12	DB0	Data bit 0
13	DB1	Data bit 1
14	DB2	Data bit 2
15	DB3	Data bit 3
16	DB4	Data bit 4
17	DB5	Data bit 5
18	DB6	Data bit 6
19	DB7	Data bit 7
20	NC	NO CONNECTION
A		3.2V
K		0V

8.0 APPLICATION

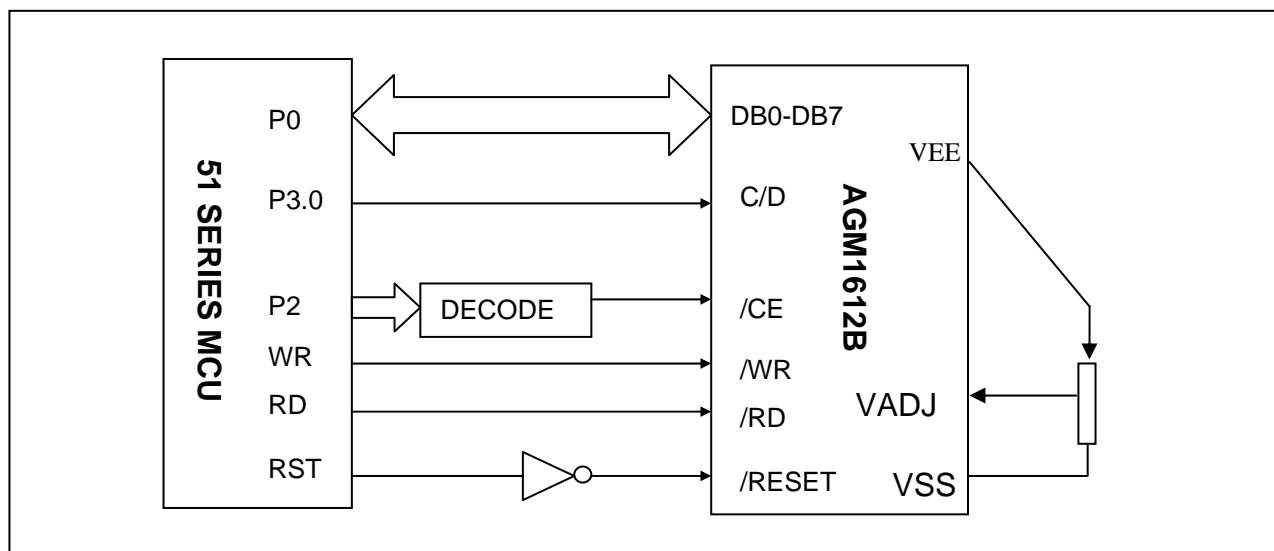

9.0 TIMING CHARACTERISTICS

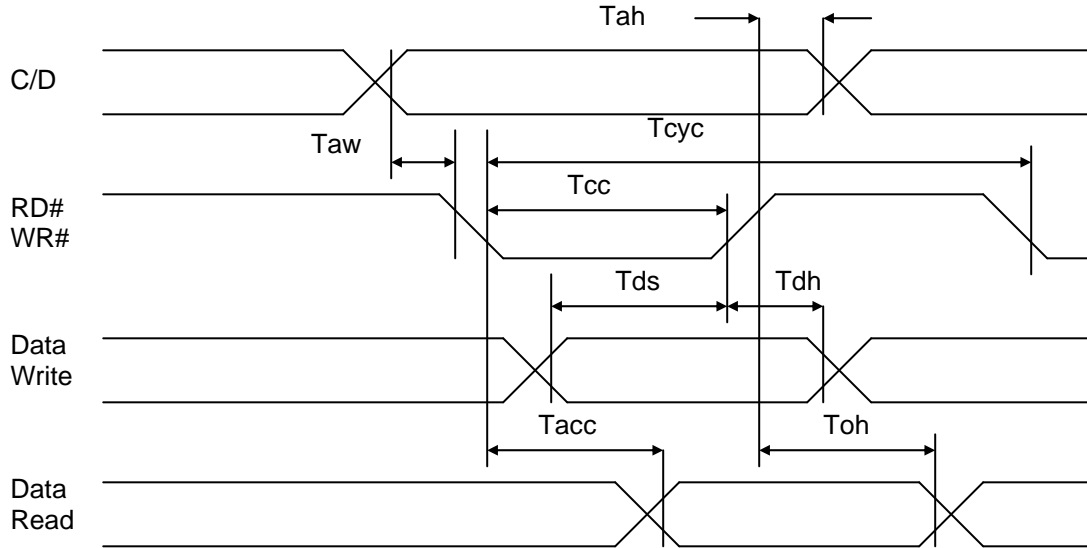

ITEM	SYMBLE	MIN	MAX	UNIT
Address Setup Time	T _{aw}	10		ns
Address Hold Time	T _{ah}	10		ns
RD#,WR# Cycle	T _{cyc}	200		ns
RD#,WR# Pulse Width	T _{cc}	80		ns
Data Setup Time	T _{ds}	80		ns
Data Hold Time (Write)	T _{dh}	40		ns
Data Access Time	T _{acc}		150	ns
Data Hold Time (Read)	T _{oh}	10	50	ns

10.0 RELIABILITY TEST

Storage Condition	Content	Evaluations and Assessment*			
		Current Consumption	Oozing	Contrast	Other Appearances
Operation at high temperature and humidity	40°C, 90% RH, 96hrs	Twice initial value or less	none	More than 80% of initial value	No abnormality
High temperature storage	60°C, 96hrs	Twice initial value or less	none	More than 80% of initial value	No abnormality
Low temperature storage	-20°C, 96hrs	Twice initial value or less		More than 80% of initial value	No abnormality

*Evaluations and assessment to be made two hours after returning to room temperature (25°C±5°C).

*The LCDs subjected to the test must not have dew condensation.

11.0 DISPLAY CONTROL INSTRUCTION

The display control instructions control the internal state of the T6963c.

COMMAND	Control State			Code								DESCRIPTION
	CD	RD	WR	D7	D6	D5	D4	D3	D2	D1	D0	
REGISTERS SETTIBG	1	1	0	0	0	1	0	0	N2	N1	N0	N2 N1 N0 0 0 1 Set Cursor Pointer 0 1 0 Set Offset Register 1 0 0 Set address Pointer
SET CONTROL WORD	1	1	0	0	1	0	0	0	0	N1	N0	N1 N0 0 0 Set Text Home Address 1 1 Set Text Area 2 0 Set Graphic Home Address 1 1 Set Graphic Area
MODE SET	1	1	0	1	0	0	0	CG	N2	N1	N0	CG=0: Internal CG ROM Mode CG=1: Internal CG ROM Mode N2 N1 N0 Graphic & Text 0 0 0 OR Mode 0 0 1 Exor Mode 0 1 1 And Mode 1 0 0 Text Attribute Mode
DISPLAY MODE	1	1	0	1	0	0	1	N3	N2	N1	N0	N3=0: Display Off N3=1: Display On N2=0:Text Off N2=1: Text On N1=0: Cursor Off N1=1: Cursor On N0=0: Blink Off N0=1: Blink On
CURSOR PATTERN SELECT	1	1	0	1	0	1	0	0	N2	N1	N0	N2,N1,N0 Line Number of Cursor N2 N1 N0 0 0 0 1-Line Cursor (Bottom Line) 1 1 1 8-Line Cursor (8x8Dots)
DATA AUTO READ/WRITE	1	1	0	1	0	1	1	0	0	N1	N0	N1 N0 0 0 Data Auto Write 0 1 Data Auto Read 1 * Auto Reset
DATA READ/WRITE	1	1	0	1	1	0	0	0	N2	N1	N0	N2=0: ADP Variable N2=1: ADP Nonvariable N1=0: Increment ADP N1 =1: Decrement ADP N0=0: Data Write N0=1: Data Read
SCREEN PEEK	1	1	0	1	1	1	0	0	0	0	0	Screen Peek
SCREEN COPY	1	1	0	1	1	1	0	1	0	0	0	Screen Copy
BIT SET/RESET	1	1	0	1	1	1	1	N3	N2	N1	N0	N3=0: Bit Reset N3=1: Bit Set N2, N1, N0 Bit Address 000-D0, 111-D7
DATA WRITE	0	1	0	Write Data								Writes data DB0~DB7 into display data RAM. After writing instruction
DATA READ	0	0	1	Read Data								Reads data DB0~DB7 from display data RAM to the data bus.

12.0 RECAUTION FOR USING LCM

1. When design the product with this LCD Module, make sure the viewing angle matches to its purpose of usage.
2. As LCD panel is made of glass substrate, Dropping the LCD module or banging it against hard objects may cause cracking or fragmentation. Especially at corners and edges.
3. Although the polarizer of this LCD Module has the anti-glare coating, always be careful not to scratch its surface. Use of a plastic cover is recommended to protect the surface of polarizer.
4. If the LCD module is stored at below specified temperature, the LC material may freeze and be deteriorated. If it is stored at above specified temperature, the molecular orientation of the LC material may change to Liquid state and it may not revert to its original state. Excessive temperature and humidity could cause polarizer peel off or bubble. Therefore, the LCD module should always be stored within specified temperature range.
5. Saliva or water droplets must be wiped off immediately as those may leave stains or cause color changes if remained for a long time. Water vapor will cause corrosion of ITO electrodes.
6. If the surface of LCD panel needs to be cleaned, wipe it swiftly with cotton or other soft cloth. If it is not still clean enough, blow a breath on the surface and wipe again.
7. The module should be driven according to the specified ratings to avoid malfunction and permanent damage. Applying DC voltage cause a rapid deterioration of LC material. Make sure to apply alternating waveform by continuous application of the M signal. Especially the power ON/OFF sequence should be kept to avoid latch-up of driver LSIs and DC charge up to LCD panel.
8. Mechanical Considerations
 - a) LCM are assembled and adjusted with a high degree of precision. Avoid excessive shocks and do not make any alterations or modifications. The following should be noted.
 - b) Do not tamper in any way with the tabs on the metal frame.
 - c) Do not modify the PCB by drilling extra holes, changing its outline, moving its components or modifying its pattern.
 - d) Do not touch the elastomer connector; especially insert a backlight panel (for example, EL).
 - e) When mounting a LCM makes sure that the PCB is not under any stress such as bending or twisting. Elastomer contacts are very delicate and missing pixels could result from slight dislocation of any of the elements.
 - f) Avoid pressing on the metal bezel, otherwise the elastomer connector could be deformed and lose contact, resulting in missing pixels.
9. Static Electricity
 - a) Operator

Wear the electrostatics shielded clothes because human body may be statically charged if not wear shielded clothes. Never touch any of the conductive parts such as the LSI pads; the copper leads on the PCB and the interface terminals with any parts of the human body.

b) Equipment

There is a possibility that the static electricity is charged to the equipment, which has a function of peeling or friction action (ex: conveyer, soldering iron, working table). Earth the equipment through proper resistance (electrostatic earth: 1×10^8 ohm).

Only properly grounded soldering irons should be used.

If an electric screwdriver is used, it should be well grounded and shielded from commutator sparks.

The normal static prevention measures should be observed for work clothes and working benches; for the latter conductive (rubber) mat is recommended.

c) Floor

Floor is the important part to drain static electricity, which is generated by operators or equipment.

There is a possibility that charged static electricity is not properly drained in case of insulating floor. Set the electrostatic earth (electrostatic earth: 1×10^8 ohm).

d) Humidity

Proper humidity helps in reducing the chance of generating electrostatic charges. Humidity should be kept over 50%RH.

e) Transportation/storage

The storage materials also need to be anti-static treated because there is a possibility that the human body or storage materials such as containers may be statically charged by friction or peeling.

The modules should be kept in antistatic bags or other containers resistant to static for storage.

f) Soldering

Solder only to the I/O terminals. Use only soldering irons with proper grounding and no leakage.

Soldering temperature : $280^{\circ} \text{C} \pm 10^{\circ} \text{C}$

AGM1612B-FLW-FBW GRAPHIC MODULE VER2.0

Soldering time: 3 to 4 sec.

Use eutectic solder with resin flux fill.

If flux is used, the LCD surface should be covered to avoid flux spatters. Flux residue should be removed afterwards.

g) Others

The laminator (protective film) is attached on the surface of LCD panel to prevent it from scratches or stains. It should be peeled off slowly using static eliminator.

Static eliminator should also be installed to the workbench to prevent LCD module from static charge.

10. Operation

- a) Driving voltage should be kept within specified range; excess voltage shortens display life.
 - b) Response time increases with decrease in temperature.
 - c) Display may turn black or dark blue at temperatures above its operational range; this is (however not pressing on the viewing area) may cause the segments to appear "fractured".
 - d) Mechanical disturbance during operation (such as pressing on the viewing area) may cause the segments to appear "fractured".
11. If any fluid leaks out of a damaged glass cell, wash off any human part that comes into contact with soap and water. The toxicity is extremely low but caution should be exercised at all the time.
 12. Disassembling the LCD module can cause permanent damage and it should be strictly avoided.
 13. LCD retains the display pattern when it is applied for long time (Image retention). To prevent image retention, do not apply the fixed pattern for a long time. Image retention is not a deterioration of LCD. It will be removed after display pattern is changed.
 14. Do not use any materials, which emit gas from epoxy resin (hardener for amine) and silicone adhesive agent (dealcohol or deoxym) to prevent discoloration of polarizer due to gas.
 15. Avoid the exposure of the module to the direct sunlight or strong ultraviolet light for a long time. The brightness of LCD module may be affected by the routing of CCFL cables due to leakage to the chassis through coupling effect. The inverter circuit needs to be designed taking the level of leakage current into consideration. Thorough evaluation is needed for LCD module and inverter built into its host equipment to