

DE3512C/DE3518C

Inductance Range: 0.68~22 μ H (DE3512C), 0.56~22 μ H (DE3518C)

DIMENSIONS / 外形寸法図

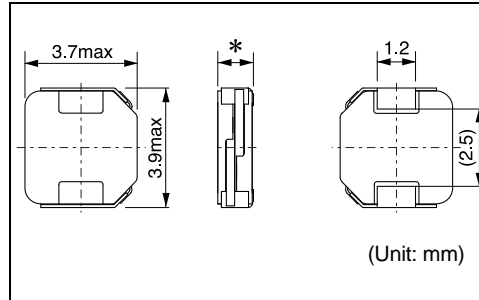

*DE3512C: 1.2mm Max.
DE3518C: 1.8mm Max.

Recommended patterns

推奨パターン図

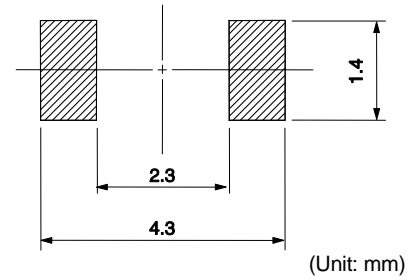

FEATURES / 特長

- Low profile (3.5 × 3.7mm square, 1.2 and 1.8mm Max. height).
- Magnetically shielded construction and low DC resistance.
- Ideal for a variety of DC-DC converter inductor applications. (DVC,DSC,Cellular phone,PDA)
- RoHS compliant.
- 小型薄形構造(3.5 × 3.7mm角, 高さ1.2および1.8mm Max.)
- 閉磁路構造、低直流抵抗
- 各種機器のDC-DCコンバータ用インダクタに最適 (DVC,DSC,Cellular phone,PDA)
- RoHS指令対応

SELECTION GUIDE FOR STANDARD COILS

TYPE DE3512C (Magnetically Shielded) 閉磁路タイプ (Quantity/reel; 2,000 PCS)

東光品番	インダクタンス ⁽¹⁾	許容差	直流抵抗 ⁽²⁾	直流重畳許容電流 ⁽³⁾	温度上昇許容電流 ⁽³⁾
TOKO Part Number	Inductance ⁽¹⁾ (μ H)	Tolerance (%)	DC Resistance ⁽²⁾ (m Ω) Max. (Typ.)	Inductance Decrease Current ⁽³⁾ (A) Max. (Typ.) $\frac{\Delta L}{L} = 30\%$	Temperature Rise Current ⁽³⁾ ($\Delta T=40^\circ\text{C}$) (A) Max. (Typ.)
1094AS-R68N	0.68	± 30	36 (30)	2.10 (2.80)	2.70 (3.20)
1094AS-1R0N	1.0	± 30	46 (38)	1.80 (2.40)	2.40 (2.90)
1094AS-1R5N	1.5	± 30	54 (45)	1.50 (2.00)	2.20 (2.60)
1094AS-2R0M	2.0	± 20	64 (53)	1.30 (1.80)	2.00 (2.40)
1094AS-2R7M	2.7	± 20	72 (60)	1.20 (1.60)	1.90 (2.20)
1094AS-3R3M	3.3	± 20	78 (65)	1.00 (1.40)	1.80 (2.10)
1094AS-4R7M	4.7	± 20	100 (83)	0.85 (1.20)	1.60 (1.90)
1094AS-6R8M	6.8	± 20	138 (115)	0.69 (0.93)	1.30 (1.60)
1094AS-100M	10.0	± 20	216 (180)	0.57 (0.76)	1.00 (1.20)
1094AS-120M	12.0	± 20	276 (230)	0.52 (0.69)	0.89 (1.00)
1094AS-150M	15.0	± 20	354 (295)	0.47 (0.62)	0.75 (0.88)
1094AS-220M	22.0	± 20	468 (390)	0.37 (0.50)	0.65 (0.77)

continued from previous page
前頁より続く

SELECTION GUIDE FOR STANDARD COILS

TYPE DE3518C (Magnetically Shielded)閉磁路タイプ (Quantity/reel; 2,000 PCS)

東光品番	インダクタンス ⁽¹⁾	許容差	直流抵抗 ⁽²⁾	直流重畳許容電流 ⁽³⁾	温度上昇許容電流 ⁽³⁾
TOKO Part Number	Inductance ⁽¹⁾ (μ H)	Tolerance (%)	DC Resistance ⁽²⁾ (m Ω) Max. (Typ.)	Inductance Decrease Current ⁽³⁾ (A) Max. (Typ.) $\frac{\Delta L}{L} = 30\%$	Temperature Rise Current ⁽³⁾ $\Delta T = 40^\circ\text{C}$ (A) Max. (Typ.)
1127AS-R56N	0.56	± 30	29 (24)	3.30 (4.40)	3.40 (4.00)
1127AS-1R2N	1.2	± 30	36 (30)	2.40 (3.20)	2.90 (3.40)
1127AS-1R7N	1.7	± 30	42 (35)	2.10 (2.75)	2.70 (3.20)
1127AS-2R2M	2.2	± 20	48 (40)	1.90 (2.55)	2.55 (3.00)
1127AS-2R7M	2.7	± 20	54 (45)	1.70 (2.30)	2.40 (2.85)
1127AS-3R3M	3.3	± 20	60 (50)	1.60 (2.10)	2.25 (2.70)
1127AS-4R7M	4.7	± 20	72 (60)	1.35 (1.75)	2.00 (2.45)
1127AS-6R4M	6.4	± 20	102 (85)	1.15 (1.50)	1.65 (2.00)
1127AS-100M	10.0	± 20	174 (145)	0.90 (1.20)	1.25 (1.50)
1127AS-120M	12.0	± 20	186 (155)	0.85 (1.15)	1.20 (1.45)
1127AS-150M	15.0	± 20	222 (185)	0.80 (1.05)	1.10 (1.30)
1127AS-220M	22.0	± 20	342 (285)	0.65 (0.84)	0.88 (1.05)

(1) Inductance is measured with a LCR meter 4284A* or equivalent.

Test frequency at 100kHz

(2) DC Resistance is measured with a Digital Multimeter TR6871 (ADVANTEST) or equivalent.

(3) Maximum allowable DC current is that which causes a 30% inductance reduction from the initial value, coil temperature to rise by 40 , whichever is smaller. (Reference ambient temperature 20)

* Agilent Technologies

(1) インダクタンスはLCRメータ4284A* または同等品により測定する。測定周波数は100kHzです。

(2) 直流抵抗はデジタルマルチメータTR6871(Advantest)または同等品により測定する

(3) 最大許容電流は、直流重畳電流を流した時インダクタンスの値が初期値より30%減少する直流電流値、または直流電流により、コイルの温度が40 上昇の何れか小さい値です。(周囲温度20を基準とする。)

* Agilent Technologies