

# XC6214 Series



*500mA Output Current, High Speed LDO Regulators, Thermal Shutdown Function, Ceramic Capacitor Compatible*

- ◆ CMOS Low Power Consumption : 8  $\mu$  A (TYP.)
- ◆ Maximum Output Current : More than 500mA
- ◆ Current Limit Circuit Built-In
- ◆ Thermal Shutdown Circuit Built-In
- ◆ Ceramic Capacitor Compatible
- ◆ SOT-89-, SOT-26 Packages

## ■ GENERAL DESCRIPTION

The XC6214 series are highly precise, low noise, high current, positive voltage low dropout regulators. They are fabricated using Torex's CMOS process. The series features a voltage reference, an error amplifier, a current limiter, a thermal protection circuit, and a phase compensation circuit plus a driver transistor.

The output voltage is selectable in 100mV increments within the range of 1.5V to 5.0V. (Output voltage 1.5V, 1.8V, 2.5V, 3.0V and 3.3V are standard products. Other than these voltages are available as semi-custom products.)

The series is also compatible with low ESR ceramic capacitors, which give added output stability. This stability can be maintained even during load fluctuations due to the excellent transient response of the series.

The over current protection circuit and the thermal shutdown circuit are built in. The over current protection circuit will operate when the output current reaches current limit level. The thermal shutdown circuit will operate when the junction temperature reaches temperature limit level.

## ■ TYPICAL APPLICATION CIRCUIT

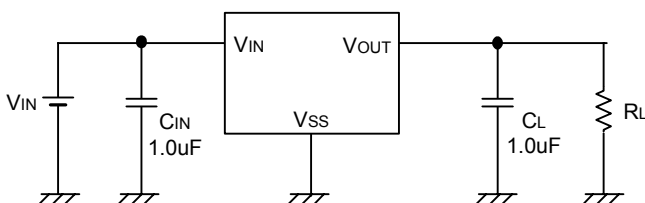

## ■ APPLICATIONS

- DVD, CD-ROM, HDD drive equipment
- Portable AV equipment (Cameras, VCRs, etc.)
- Wireless Communication equipment (Mobile & Cordless phone, etc.)
- Desktop computers, Note book computer, PDAs
- Network equipment (Wireless LAN etc.)
- Reference voltage
- Battery powered equipment

## ■ FEATURES

- Maximum Output Current** : More than 500mA (800mA limit)
- Dropout Voltage** : 500mV @ IOUT = 500mA (VOUT=3.3V)
- Operating Voltage Range** : 1.8V ~ 6.0V
- Output Voltage** : 1.5V, 1.8V, 2.5V, 3.0V, 3.3V (standard)  
Other voltages between 1.5V to 5.0V (semi-custom)
- High Accuracy** : Setting voltage accuracy  $\pm 2\%$
- Low Power Consumption** : 8  $\mu$  A (TYP.)
- Ripple Rejection Rate** : 40dB @ 1kHz
- Operating Temperature Range** : - 40°C ~ 85°C
- Packages** : SOT-26  
SOT-89

## ■ TYPICAL PERFORMANCE CHARACTERISTICS

○ Dropout Voltage vs. Output Current

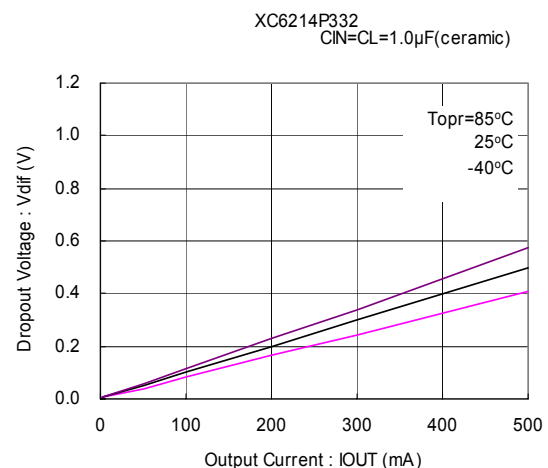

## ■ PIN CONFIGURATION

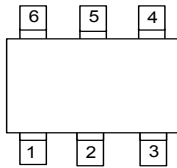

SOT-26 (TOP VIEW)

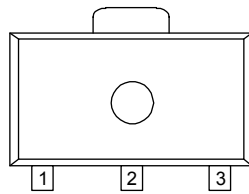

SOT-89 (TOP VIEW)

\* The 2, 4 and 5 pins of the SOT-26 package are the common Vss pins in the package.  
For a heat design, in case of connecting the heat dissipation pad to a circuit, Please use the 2, 4, and 5 pins as the Vss pin on the PCB board

## ■ PIN ASSIGNMENT

PIN NUMBER		PIN NAME	FUNCTIONS
SOT-26	SOT-89		
1	2	VIN	Power Input
2, 4, 5	1	VSS	Ground
3	-	NC	No Connection
6	3	VOUT	Output

## ■ PRODUCT CLASSIFICATION

### ● Ordering Information

XC6214P ①②③④⑤

DESIGNATOR	DESCRIPTION	SYMBOL	DESCRIPTION
① ②	Output Voltage	15 ~ 50	: ex.) 3.0V products → ①=3, ②=0
③	Output Voltage Accuracy	2	: Within $\pm 2\%$ ex.) 2.50V products → ①=2, ②=5, ③=2
④	Package	M	: SOT-26
		P	: SOT-89
⑤	Device Orientation	R	: Embossed tape, standard feed
		L	: Embossed tape, reverse feed

## ■ PACKAGING INFORMATION

● SOT-26

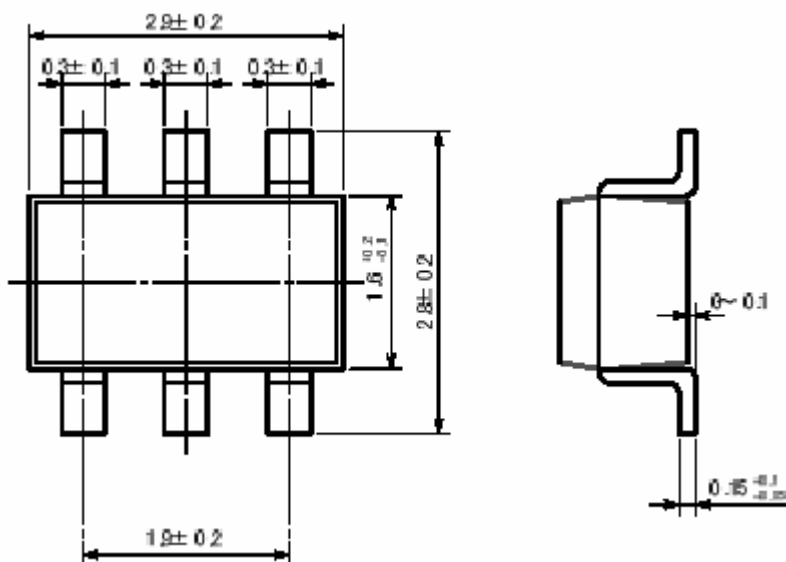

● SOT-89

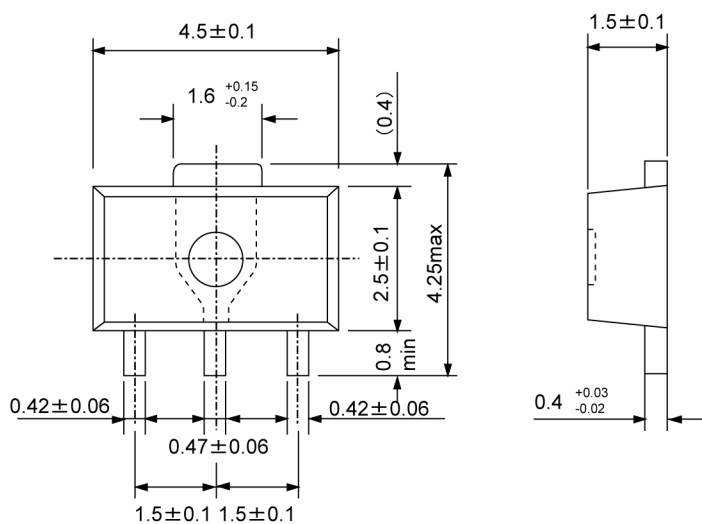

## MARKING RULE

### ● SOT-89

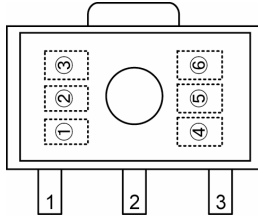

SOT-89  
(TOP VIEW)

① Represents product series

MARK	PRODUCT SERIES
D	XC6214Pxx2xx

② Represents output voltage range

MARK	VOLTAGE (V)	PRODUCT SERIES
P	1.5 ~ 3.0	XC6214Pxx2xx
R	3.1 ~ 5.0	XC6214Pxx2xx

③ Represents output voltage

MARK	VOLTAGE (V)		MARK	VOLTAGE (V)	
0	-	3.1	F	1.6	4.6
1	-	3.2	H	1.7	4.7
2	-	3.3	K	1.8	4.8
3	-	3.4	L	1.9	4.9
4	-	3.5	M	2.0	5.0
5	-	3.6	N	2.1	-
6	-	3.7	P	2.2	-
7	-	3.8	R	2.3	-
8	-	3.9	S	2.4	-
9	-	4.0	T	2.5	-
A	-	4.1	U	2.6	-
B	-	4.2	V	2.7	-
C	-	4.3	W	2.8	-
D	-	4.4	Y	2.9	-
E	1.5	4.5	Z	3.0	-

④ Represents the last digit of the production year (ex.)

MARK	PRODUCTION YEAR
4	2004
5	2005

⑤ Represents the production month

MARK	MONTH	MARK	MONTH	MARK	MONTH
A	January	E	May	J	September
B	February	F	June	K	October
C	March	G	July	L	November
D	April	H	August	M	December

⑥ Represents production lot number

0 to 9, A to Z repeated (G, I, J, O, Q, W excepted).

Note: No character inversion used.

## MARKING RULE (Continued)

### SOT-26

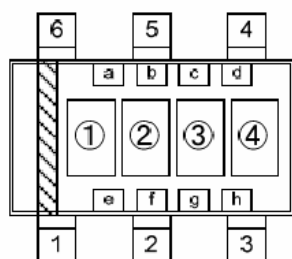

SOT-26  
(TOP VIEW)

①Represents product series

MARK	PRODUCT SERIES
D	XC6214Pxx2xx

②Represents output voltage range

MARK	VOLTAGE (V)	PRODUCT SERIES
P	1.5 ~ 3.0	XC6214Pxx2xx
R	3.1 ~ 5.0	XC6214Pxx2xx

③Represents output voltage

MARK	VOLTAGE (V)		MARK	VOLTAGE (V)	
0	-	3.1	F	1.6	4.6
1	-	3.2	H	1.7	4.7
2	-	3.3	K	1.8	4.8
3	-	3.4	L	1.9	4.9
4	-	3.5	M	2.0	5.0
5	-	3.6	N	2.1	-
6	-	3.7	P	2.2	-
7	-	3.8	R	2.3	-
8	-	3.9	S	2.4	-
9	-	4.0	T	2.5	-
A	-	4.1	U	2.6	-
B	-	4.2	V	2.7	-
C	-	4.3	W	2.8	-
D	-	4.4	Y	2.9	-
E	1.5	4.5	Z	3.0	-

④Represents production lot number

0 to 9, A to Z repeated (G, I, J, O, Q, W excepted).

Note: No character inversion used.

a, b, c, d Represents production year

MARK				PRODUCTION YEAR
a	b	c	d	
-	-	□	-	2004
-	-	-	□	2005
□	-	-	-	2006
-	□	-	-	2007

\*Markings of the year 2004 to 2007 are repeated from 2008.

ex.) 2004→2008, 2005→2009, 2006→2010, 2007→2011.

e, f, g, h Represents production month

MARK				PRODUCTION MONTH	MARK				PRODUCTION MONTH
e	f	g	h		e	f	g	h	
□	-	-	-	January	□	□	□	-	July
-	□	-	-	February	-	-	-	□	August
□	□	-	-	March	□	-	-	□	September
-	-	□	-	April	-	□	-	□	October
□	-	□	-	May	□	□	-	□	November
-	□	□	-	June	-	-	□	□	December

## ■ BLOCK DIAGRAM

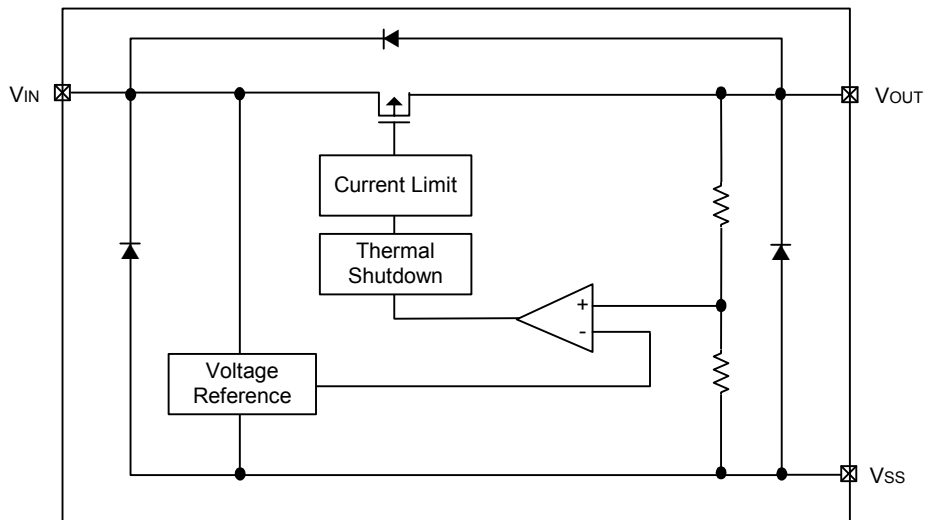

## ■ ABSOLUTE MAXIMUM RATINGS

Ta=25°C

PARAMETER	SYMBOL	RATINGS	UNITS
Input Voltage	V <sub>IN</sub>	- 0.3 ~ + 6.5	V
Output Current *	I <sub>OUT</sub>	800 *	mA
Output Voltage	V <sub>OUT</sub>	V <sub>SS</sub> - 0.3 ~ V <sub>IN</sub> + 0.3	V
Power Dissipation	SOT-26	**	mW
	SOT-89	500	
Operating Temperature Range	T <sub>opr</sub>	- 40 ~ + 85	°C
Storage Temperature Range	T <sub>stg</sub>	- 55 ~ + 125	°C

\* I<sub>OUT</sub> ≤ Pd / (V<sub>IN</sub> - V<sub>OUT</sub>)

\*\* Refer to ■ POWER DISSIPATION

## ■ ELECTRICAL CHARACTERISTICS

### ●XC6214P152

Ta=25 °C

PARAMETER	SYMBOL	CONDITIONS	MIN.	TYP.	MAX.	UNITS	CIRCUIT
Output Voltage	V <sub>OUT(E)</sub> (*1)	V <sub>IN</sub> =2.5V, I <sub>OUT</sub> =50mA	1.470	1.500	1.530	V	①
Maximum Output Current	I <sub>OUTmax</sub>	V <sub>IN</sub> =2.5V, V <sub>OUT</sub> =V <sub>OUT(E)</sub> × 0.90	500	-	-	mA	①
Load Regulation	ΔV <sub>OUT</sub>	V <sub>IN</sub> =2.5V, 1mA ≤ I <sub>OUT</sub> ≤ 200mA	-	20	50	mV	①
Dropout Voltage (*2)	V <sub>dif</sub>	I <sub>OUT</sub> =500mA	-	800	1200	mV	①
Supply Current	I <sub>SS</sub>	V <sub>IN</sub> =2.5V	-	8	15	μA	②
Line Regulation	$\frac{\Delta V_{OUT}}{\Delta V_{IN} \cdot V_{OUT}}$	I <sub>OUT</sub> =50mA 2.5V ≤ V <sub>IN</sub> ≤ 6.0V	-	0.05	0.20	% / V	①
Input Voltage	V <sub>IN</sub>		1.8	-	6.0	V	-
Output Voltage Temperature Characteristics	$\frac{\Delta V_{OUT}}{\Delta T_{opr} \cdot V_{OUT}}$	I <sub>OUT</sub> =50mA - 40°C ≤ T <sub>opr</sub> ≤ 85°C	-	± 100	-	ppm / °C	①
Short-Circuit Current	I <sub>lim</sub>	V <sub>IN</sub> =2.5V, V <sub>OUT</sub> =0V	-	50	-	mA	①

NOTE:

\*1: V<sub>OUT(E)</sub>: Effective output voltage (i.e. the output voltage when “V<sub>OUT(T)</sub>+1.0V” is provided at the V<sub>IN</sub> pin while maintaining a certain I<sub>OUT</sub> value.)

\*2: V<sub>dif</sub>={V<sub>IN1</sub><sup>(4)</sup> -V<sub>OUT1</sub><sup>(3)</sup>}

\*3: V<sub>OUT1</sub>= A voltage equal to 98% of the output voltage whenever an amply stabilized I<sub>OUT</sub> {V<sub>OUT(T)</sub>+1.0V} is input.

\*4: V<sub>IN1</sub>=The Input Voltage when V<sub>OUT1</sub> appears as input voltage is gradually decreased.

\*5: Unless otherwise stated, {V<sub>IN</sub>=V<sub>OUT(T)</sub> +1.0V}

### ●XC6214P182

Ta=25 °C

PARAMETER	SYMBOL	CONDITIONS	MIN.	TYP.	MAX.	UNITS	CIRCUIT
Output Voltage	V <sub>OUT(E)</sub> (*1)	V <sub>IN</sub> =2.8V, I <sub>OUT</sub> =50mA	1.764	1.800	1.836	V	①
Maximum Output Current	I <sub>OUTmax</sub>	V <sub>IN</sub> =2.85V, V <sub>OUT</sub> =V <sub>OUT(E)</sub> × 0.90	500	-	-	mA	①
Load Regulation	ΔV <sub>OUT</sub>	V <sub>IN</sub> =2.8V, 1mA ≤ I <sub>OUT</sub> ≤ 200mA	-	20	50	mV	①
Dropout Voltage (*2)	V <sub>dif</sub>	I <sub>OUT</sub> =500mA	-	700	1050	mV	①
Supply Current	I <sub>SS</sub>	V <sub>IN</sub> =2.8V	-	8	15	μA	②
Line Regulation	$\frac{\Delta V_{OUT}}{\Delta V_{IN} \cdot V_{OUT}}$	I <sub>OUT</sub> =50mA 2.8V ≤ V <sub>IN</sub> ≤ 6.0V	-	0.05	0.20	% / V	①
Input Voltage	V <sub>IN</sub>		1.8	-	6.0	V	-
Output Voltage Temperature Characteristics	$\frac{\Delta V_{OUT}}{\Delta T_{opr} \cdot V_{OUT}}$	I <sub>OUT</sub> =50mA - 40°C ≤ T <sub>opr</sub> ≤ 85°C	-	± 100	-	ppm / °C	①
Short-Circuit Current	I <sub>lim</sub>	V <sub>IN</sub> =2.8V, V <sub>OUT</sub> =0V	-	50	-	mA	①

NOTE:

\*1: V<sub>OUT(E)</sub>: Effective output voltage (i.e. the output voltage when “V<sub>OUT(T)</sub>+1.0V” is provided at the V<sub>IN</sub> pin while maintaining a certain I<sub>OUT</sub> value.)

\*2: V<sub>dif</sub>={V<sub>IN1</sub><sup>(4)</sup> -V<sub>OUT1</sub><sup>(3)</sup>}

\*3: V<sub>OUT1</sub>= A voltage equal to 98% of the output voltage whenever an amply stabilized I<sub>OUT</sub> {V<sub>OUT(T)</sub>+1.0V} is input.

\*4: V<sub>IN1</sub>=The Input Voltage when V<sub>OUT1</sub> appears as input voltage is gradually decreased.

\*5: Unless otherwise stated, {V<sub>IN</sub>=V<sub>OUT(T)</sub> +1.0V}

## ■ ELECTRICAL CHARACTERISTICS (Continued)

### ● XC6214P252

Ta=25 °C

PARAMETER	SYMBOL	CONDITIONS	MIN.	TYP.	MAX.	UNITS	CIRCUIT
Output Voltage	V <sub>OUT(E)</sub> (*1)	V <sub>IN</sub> =3.5V, I <sub>OUT</sub> =50mA	2.450	2.500	2.550	V	①
Maximum Output Current	I <sub>OUTmax</sub>	V <sub>IN</sub> =3.5V, V <sub>OUT</sub> =V <sub>OUT(E)</sub> × 0.93	500	-	-	mA	①
Load Regulation	ΔV <sub>OUT</sub>	V <sub>IN</sub> =3.5V, 1mA ≤ I <sub>OUT</sub> ≤ 200mA	-	20	50	mV	①
Dropout Voltage (*2)	V <sub>dif</sub>	I <sub>OUT</sub> =500mA	-	600	900	mV	①
Supply Current	I <sub>SS</sub>	V <sub>IN</sub> =3.5V	-	8	15	μA	②
Line Regulation	$\frac{\Delta V_{OUT}}{\Delta V_{IN} \cdot V_{OUT}}$	I <sub>OUT</sub> =50mA 3.5V ≤ V <sub>IN</sub> ≤ 6.0V	-	0.05	0.20	% / V	①
Input Voltage	V <sub>IN</sub>		1.8	-	6.0	V	-
Output Voltage Temperature Characteristics	$\frac{\Delta V_{OUT}}{\Delta T_{opr} \cdot V_{OUT}}$	I <sub>OUT</sub> =50mA - 40°C ≤ T <sub>opr</sub> ≤ 85°C	-	± 100	-	ppm / °C	①
Short-Circuit Current	I <sub>lim</sub>	V <sub>IN</sub> =3.5V, V <sub>OUT</sub> =0V	-	50	-	mA	①

NOTE:

\*1: V<sub>OUT(E)</sub>: Effective output voltage (i.e. the output voltage when “V<sub>OUT(T)</sub>+1.0V” is provided at the V<sub>IN</sub> pin while maintaining a certain I<sub>OUT</sub> value.)

\*2: V<sub>dif</sub>={V<sub>IN1</sub><sup>(\*4)</sup> -V<sub>OUT1</sub><sup>(\*3)</sup>}

\*3: V<sub>OUT1</sub>= A voltage equal to 98% of the output voltage whenever an amply stabilized I<sub>OUT</sub> {V<sub>OUT(T)</sub>+1.0V} is input.

\*4: V<sub>IN1</sub>=The Input Voltage when V<sub>OUT1</sub> appears as input voltage is gradually decreased.

\*5: Unless otherwise stated, {V<sub>IN</sub>=V<sub>OUT(T)</sub> +1.0V}

### ● XC6214P302

Ta=25 °C

PARAMETER	SYMBOL	CONDITIONS	MIN.	TYP.	MAX.	UNITS	CIRCUIT
Output Voltage	V <sub>OUT(E)</sub> (*1)	V <sub>IN</sub> =4.0V, I <sub>OUT</sub> =50mA	2.940	3.000	3.060	V	①
Maximum Output Current	I <sub>OUTmax</sub>	V <sub>IN</sub> =4.0V, V <sub>OUT</sub> =V <sub>OUT(E)</sub> × 0.96	500	-	-	mA	①
Load Regulation	ΔV <sub>OUT</sub>	V <sub>IN</sub> =4.0V, 1mA ≤ I <sub>OUT</sub> ≤ 200mA	-	20	50	mV	①
Dropout Voltage (*2)	V <sub>dif</sub>	I <sub>OUT</sub> =500mA	-	560	820	mV	①
Supply Current	I <sub>SS</sub>	V <sub>IN</sub> =4.0V	-	8	15	μA	②
Line Regulation	$\frac{\Delta V_{OUT}}{\Delta V_{IN} \cdot V_{OUT}}$	I <sub>OUT</sub> =50mA 4.0V ≤ V <sub>IN</sub> ≤ 6.0V	-	0.05	0.20	% / V	①
Input Voltage	V <sub>IN</sub>		1.8	-	6.0	V	-
Output Voltage Temperature Characteristics	$\frac{\Delta V_{OUT}}{\Delta T_{opr} \cdot V_{OUT}}$	I <sub>OUT</sub> =50mA - 40°C ≤ T <sub>opr</sub> ≤ 85°C	-	± 100	-	ppm / °C	①
Short-Circuit Current	I <sub>lim</sub>	V <sub>IN</sub> =4.0V, V <sub>OUT</sub> =0V	-	50	-	mA	①

NOTE:

\*1: V<sub>OUT(E)</sub>: Effective output voltage (i.e. the output voltage when “V<sub>OUT(T)</sub>+1.0V” is provided at the V<sub>IN</sub> pin while maintaining a certain I<sub>OUT</sub> value.)

\*2: V<sub>dif</sub>={V<sub>IN1</sub><sup>(\*4)</sup> -V<sub>OUT1</sub><sup>(\*3)</sup>}

\*3: V<sub>OUT1</sub>= A voltage equal to 98% of the output voltage whenever an amply stabilized I<sub>OUT</sub> {V<sub>OUT(T)</sub>+1.0V} is input.

\*4: V<sub>IN1</sub>=The Input Voltage when V<sub>OUT1</sub> appears as input voltage is gradually decreased.

\*5: Unless otherwise stated, {V<sub>IN</sub>=V<sub>OUT(T)</sub> +1.0V}



## ■ ELECTRICAL CHARACTERISTICS (Continued)

●XC6214P332

Ta=25 °C

PARAMETER	SYMBOL	CONDITIONS	MIN.	TYP.	MAX.	UNITS	CIRCUIT
Output Voltage	V <sub>OUT(E)</sub> (*1)	V <sub>IN</sub> =4.3V, I <sub>OUT</sub> =50mA	3.234	3.300	3.366	V	①
Maximum Output Current	I <sub>OUTmax</sub>	V <sub>IN</sub> =4.3V, V <sub>OUT</sub> =V <sub>OUT(E)</sub> x 0.96	500	-	-	mA	①
Load Regulation	ΔV <sub>OUT</sub>	V <sub>IN</sub> =4.3V, 1mA ≤ I <sub>OUT</sub> ≤ 200mA	-	20	50	mV	①
Dropout Voltage (*2)	V <sub>dif</sub>	I <sub>OUT</sub> =500mA	-	500	750	mV	①
Supply Current	I <sub>SS</sub>	V <sub>IN</sub> =4.3V	-	8	15	μA	②
Line Regulation	$\frac{\Delta V_{OUT}}{\Delta V_{IN} \cdot V_{OUT}}$	I <sub>OUT</sub> =50mA 4.3V ≤ V <sub>IN</sub> ≤ 6.0V	-	0.05	0.20	% / V	①
Input Voltage	V <sub>IN</sub>		1.8	-	6.0	V	-
Output Voltage Temperature Characteristics	$\frac{\Delta V_{OUT}}{\Delta T_{opr} \cdot V_{OUT}}$	I <sub>OUT</sub> =50mA - 40°C ≤ T <sub>opr</sub> ≤ 85°C	-	± 100	-	ppm / °C	①
Short-Circuit Current	I <sub>lim</sub>	V <sub>IN</sub> =4.3V, V <sub>OUT</sub> =0V	-	50	-	mA	①

**NOTE:**

\*1: V<sub>OUT(E)</sub>: Effective output voltage (i.e. the output voltage when "V<sub>OUT(T)</sub>+1.0V" is provided at the V<sub>IN</sub> pin while maintaining a certain I<sub>OUT</sub> value.)

\*2: V<sub>dif</sub>={V<sub>IN1</sub>(\*4) -V<sub>OUT1</sub>(\*3)}

\*3: V<sub>OUT1</sub>= A voltage equal to 98% of the output voltage whenever an amply stabilized I<sub>OUT</sub> {V<sub>OUT(T)</sub>+1.0V} is input.

\*4: V<sub>IN1</sub>=The Input Voltage when V<sub>OUT1</sub> appears as input voltage is gradually decreased.

\*5: Unless otherwise stated, {V<sub>IN</sub>=V<sub>OUT(T)</sub> +1.0V}

## TEST CIRCUITS

● Circuit ①

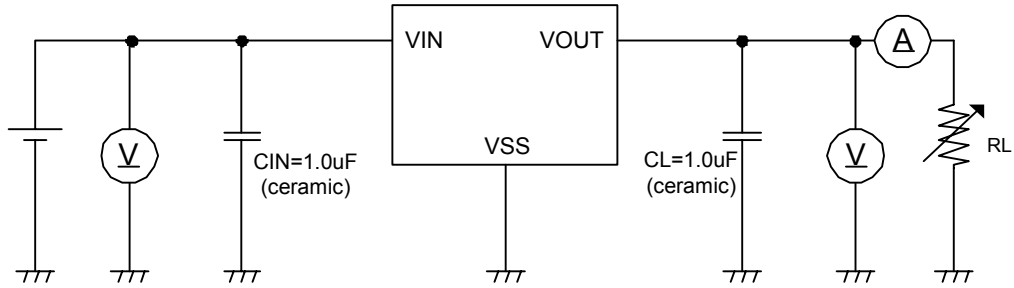

● Circuit ②

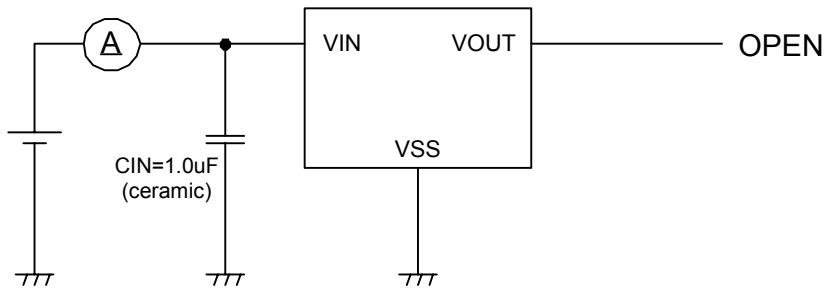

## ■ OPERATIONAL EXPLANATION

### <Output Voltage Regulator Control>

The voltage, divided by resistors R1 & R2, which are connected to the V<sub>OUT</sub> pin is compared with the internal reference voltage by the error amplifier. The P-channel MOSFET, which is connected to the V<sub>OUT</sub> pin, is then driven by the subsequent output signal. The output voltage at the V<sub>OUT</sub> pin is controlled & stabilized by negative feedback. The current limit circuit and over current protection operate in relation to the level of output current and heat.

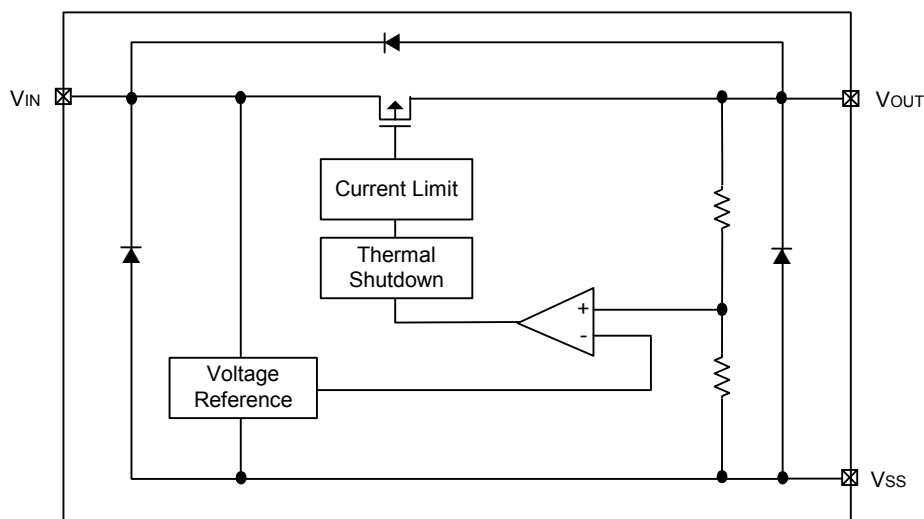

### <Low ESR Capacitors>

With the XC6214 series regulator, a stable output voltage is achievable even if low ESR capacitors are used, as a phase compensation circuit is built-in to the regulator. In order to ensure the stability of the load transient response and line transient response, we suggest that an output capacitor (C<sub>L</sub>) be connected as close as possible, between the output pin (V<sub>OUT</sub>) and the V<sub>SS</sub> pin. Please use an output capacitor (C<sub>L</sub>) with a capacitance more than 0.1 μF. We also suggest an input capacitor (C<sub>IN</sub>) of 0.1 μF: this should be connected between V<sub>IN</sub> and V<sub>SS</sub> in order to stabilize input power source.

### <Current Limiter, Short-Circuit Protection>

The XC6214 series regulator offers a combination of current limit and circuit protection by means of a built-in fixed current limiter circuit and a foldback circuit. When the output pin is shorted, a current of about 50mA flows.

### <Thermal Shutdown>

When the junction temperature of the built-in driver transistor reaches the temperature limit level (150°C TYP.), the thermal shutdown circuit operates and the driver transistor will be set to OFF. The thermal shutdown function will be released (automatically recovered) when the junction temperature decreases to the thermal shutdown release temperature level (125°C TYP.) and the IC re-starts the operation.

## ■ NOTES ON USE

1. Please use this IC within the stated absolute maximum ratings. The IC is liable to malfunction should the ratings be exceeded.
2. Where wiring impedance is high, operations may become unstable due to noise and/or phase lag depending on output current. Please strengthen V<sub>IN</sub> and V<sub>SS</sub> wiring in particular.
3. Please wire the input capacitor (C<sub>IN</sub>) and the output capacitor (C<sub>L</sub>) as close to the IC as possible.
4. Output voltage may increase when the IC is used at light load current (around 0 to 2μA) depending on temperature conditions, etc.

## ■ POWER DISSIPATION

The 2, 4 and 5 pins of the SOT-26 package are the common V<sub>SS</sub> pins at the heat dissipation pads.  
 For increasing power dissipation of the package, please use the 2, 4, and 5 pins as the V<sub>SS</sub> pin on the PCB board.

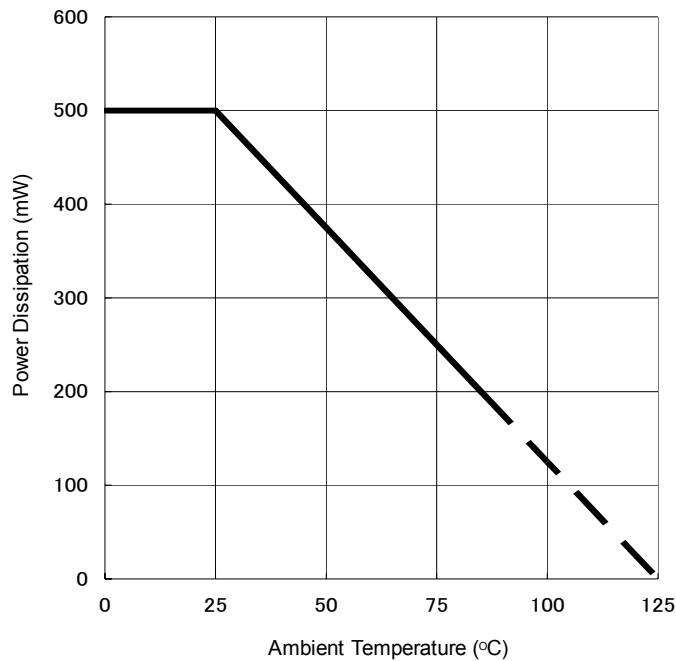

### ● SOT-26 PCB Specification

Material	: Glass epoxy G10
Size	: 25mm × 25mm
Board Thickness	: 1.0mm
Heat Dissipation Wire Size	: 23mm × 23mm
Through Holes (eleven)	: $\phi$ 0.5mm

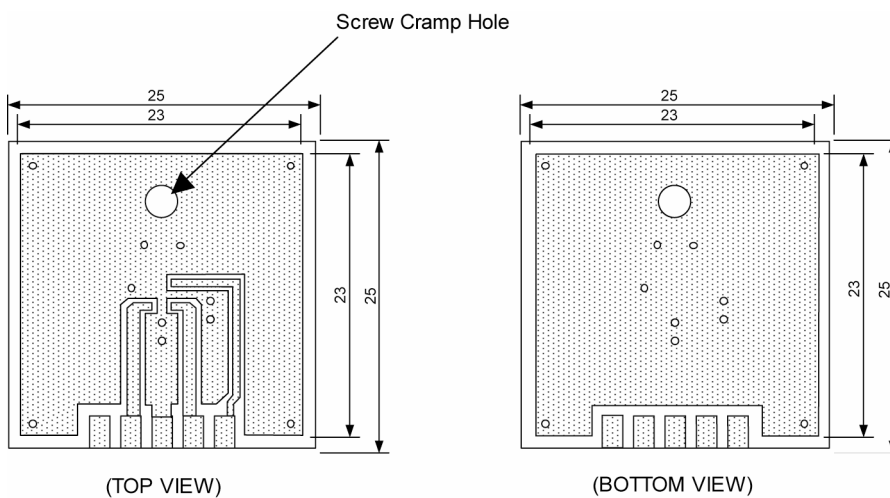

## TYPICAL PERFORMANCE CHARACTERISTICS

(1) Output Voltage vs. Output Current

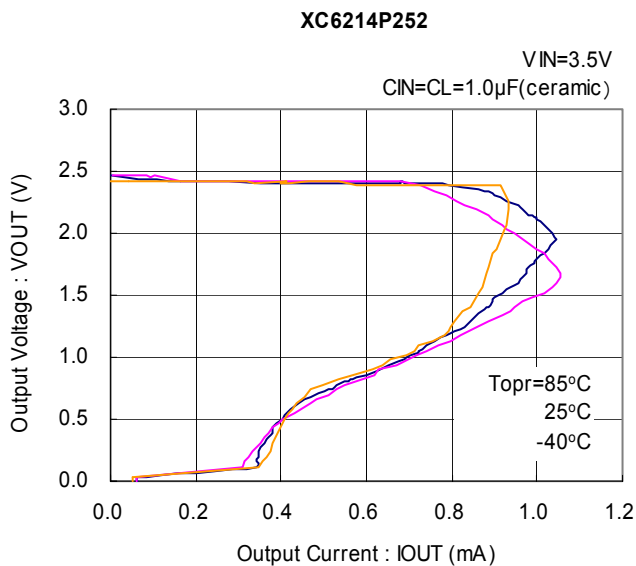
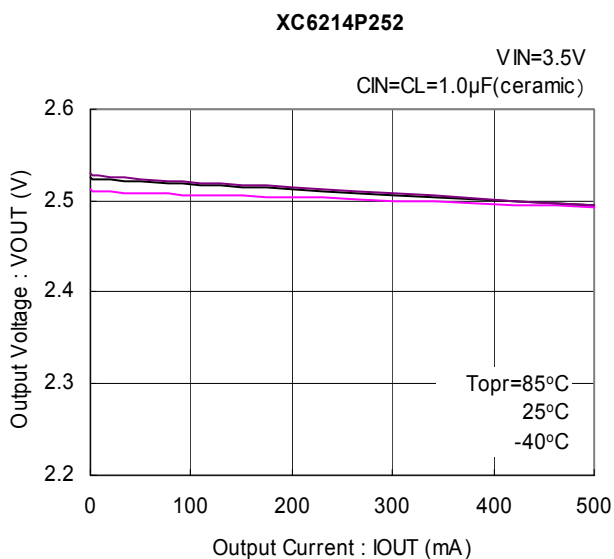
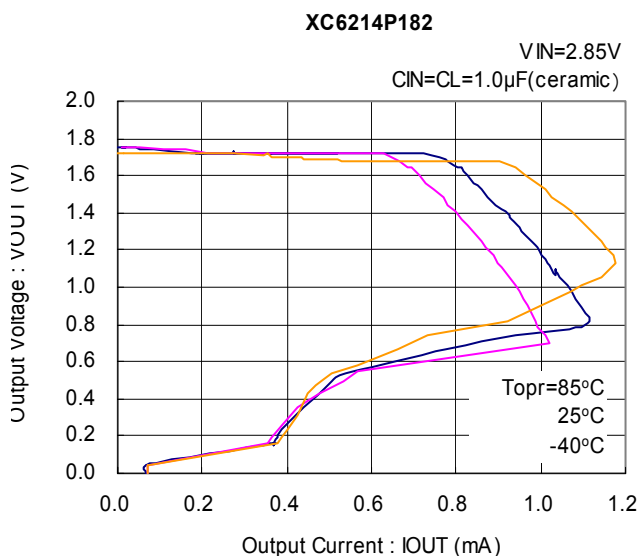
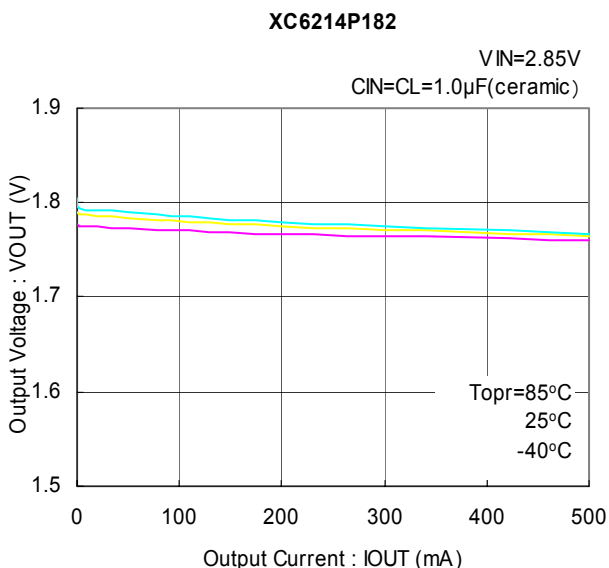
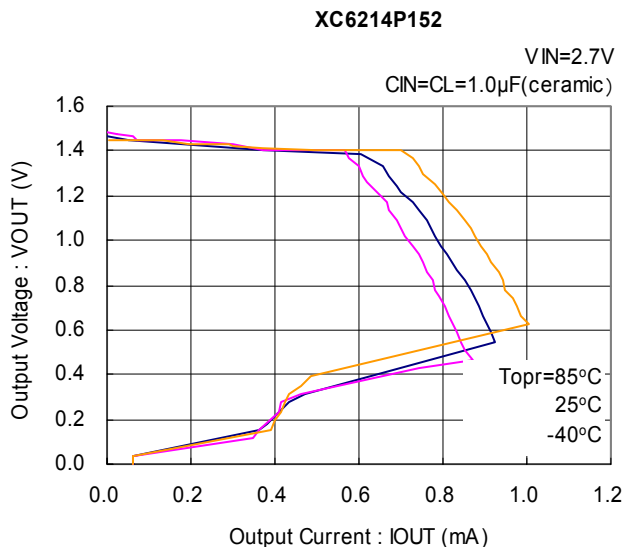
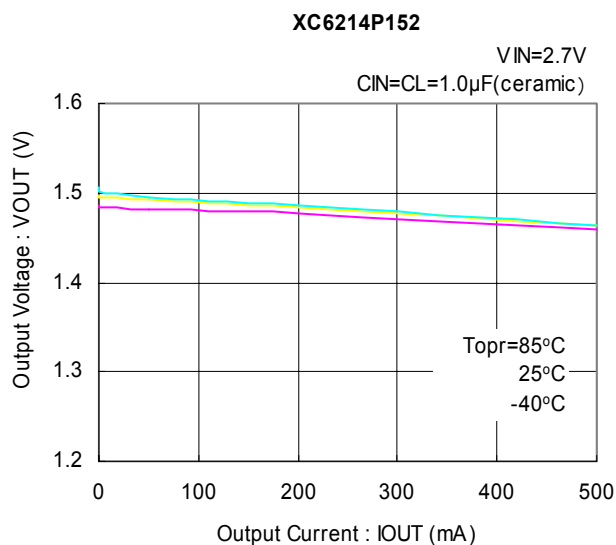

## TYPICAL PERFORMANCE CHARACTERISTICS (Continued)

(1) Output Voltage vs. Output Current (Continued)

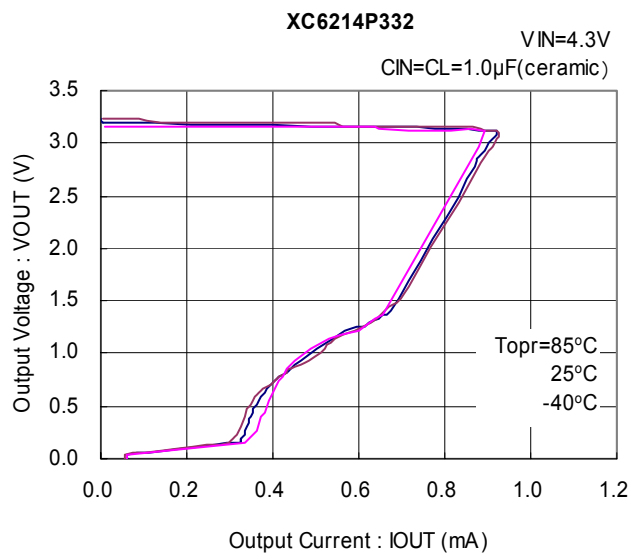
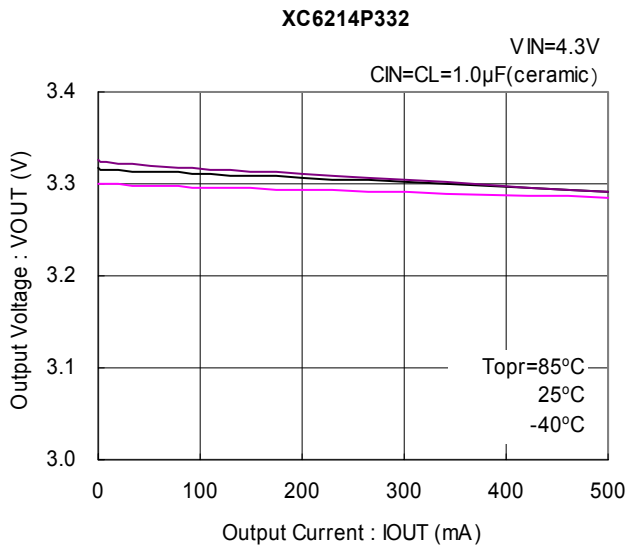

(2) Output Voltage vs. Input Voltage

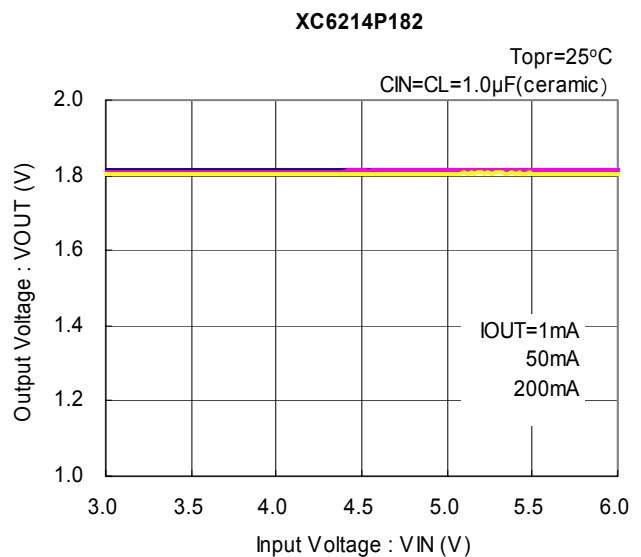
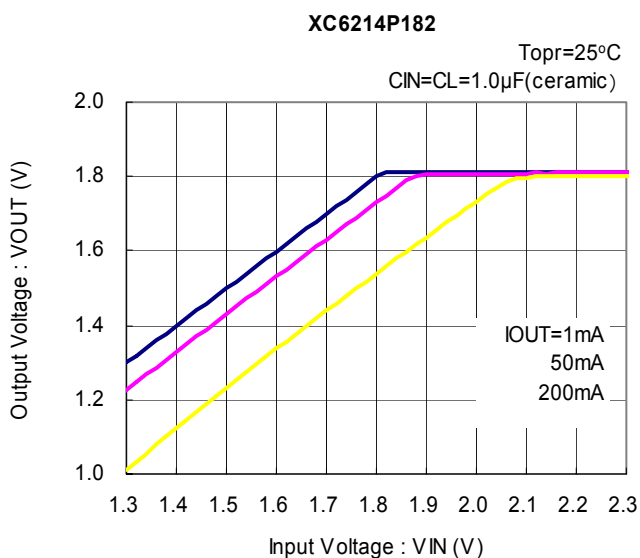
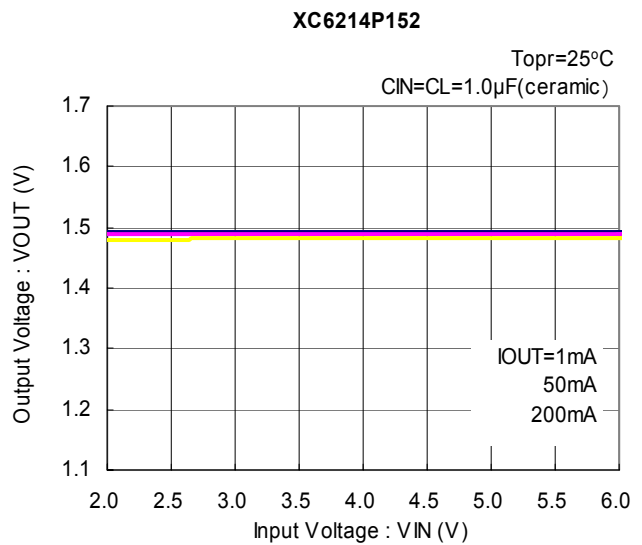
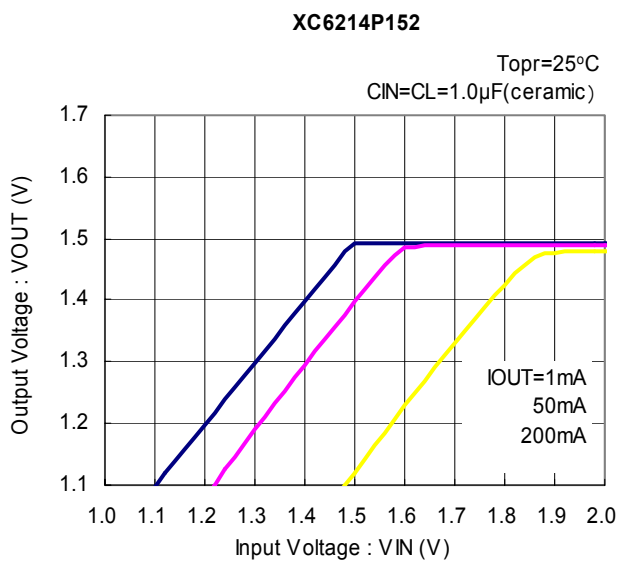

## ■ TYPICAL PERFORMANCE CHARACTER (Continued)

(2) Output Voltage vs. Input Voltage (Continued)

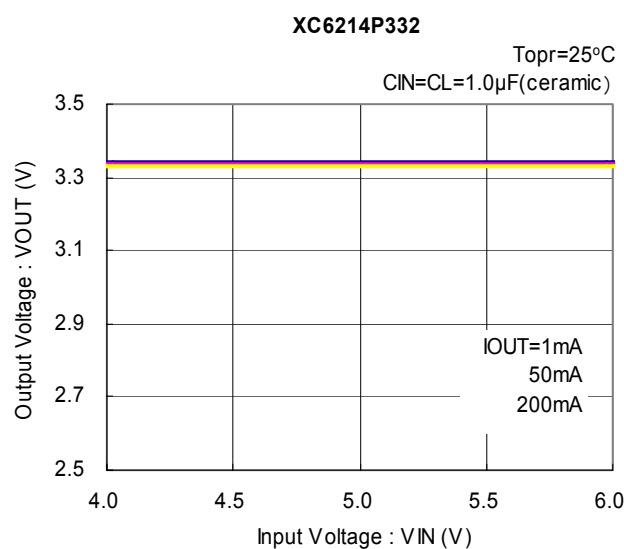
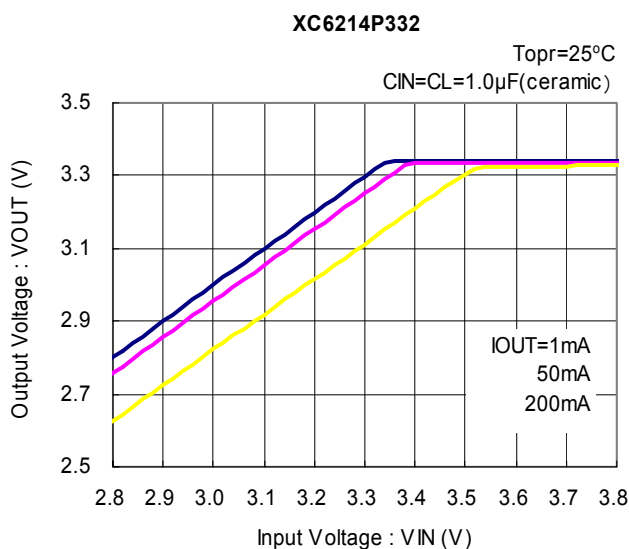
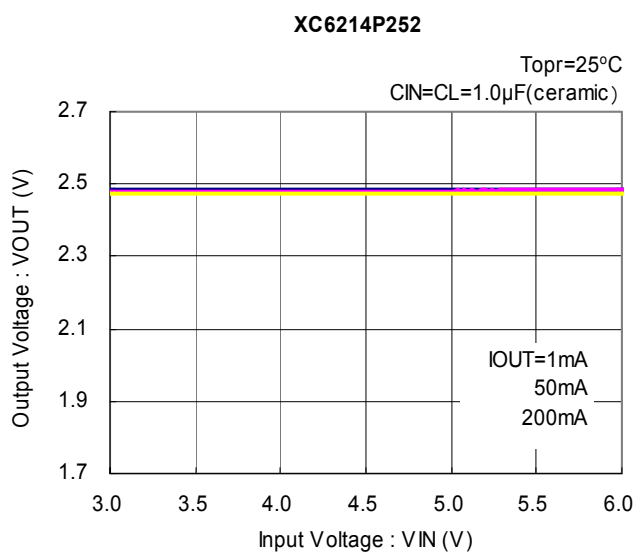
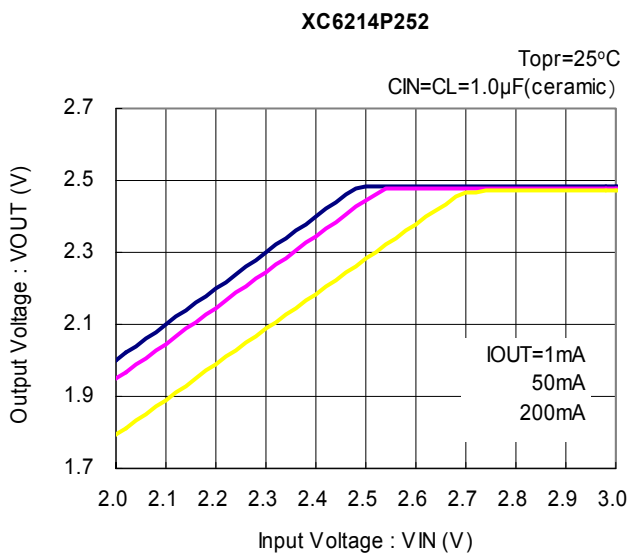

(3) Dropout Voltage vs. Output Current

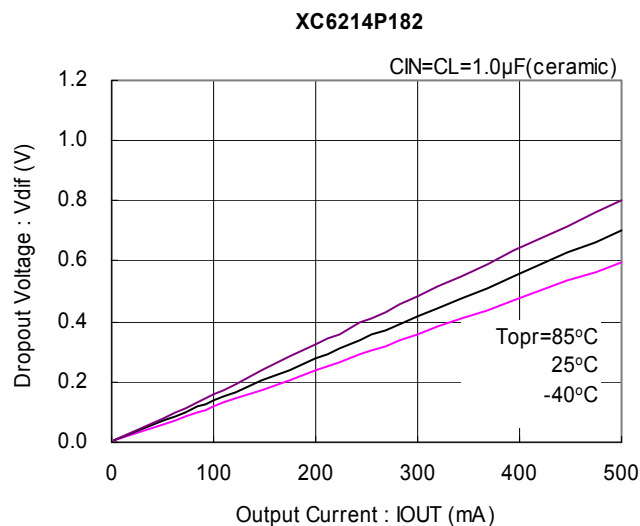
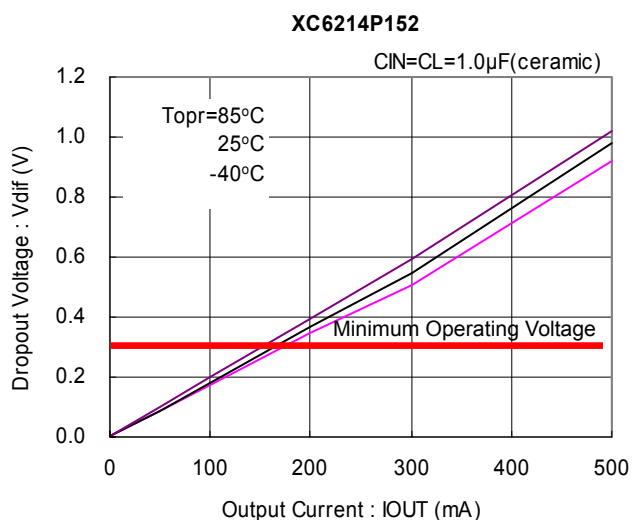

## TYPICAL PERFORMANCE CHARACTERISTICS (Continued)

(3) Dropout Voltage vs. Output Current (Continued)

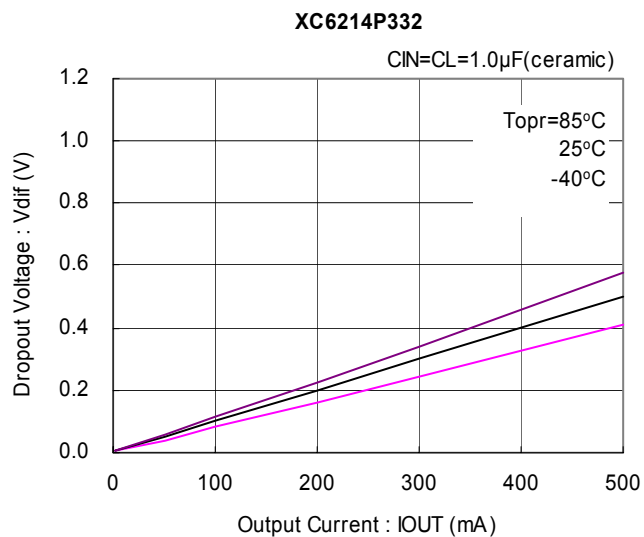
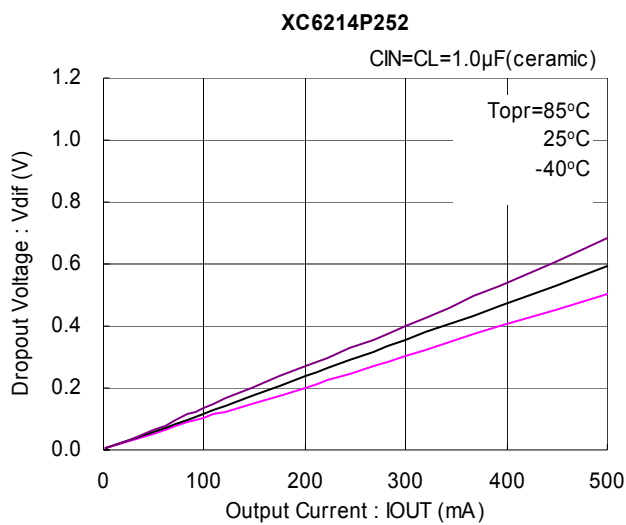

(4) Supply Current vs. Input Voltage

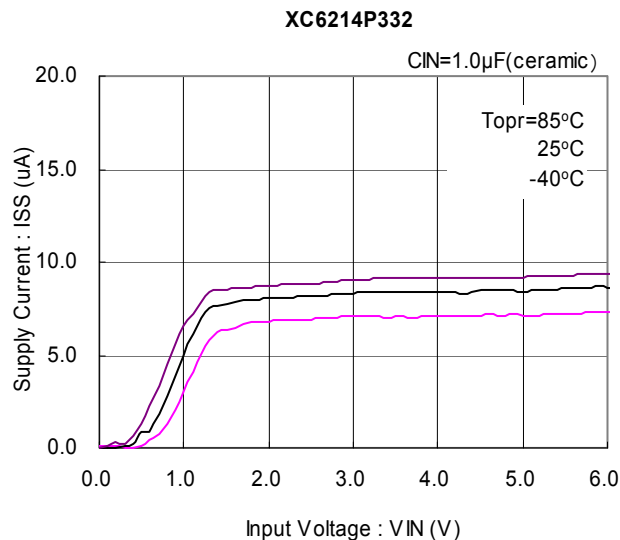
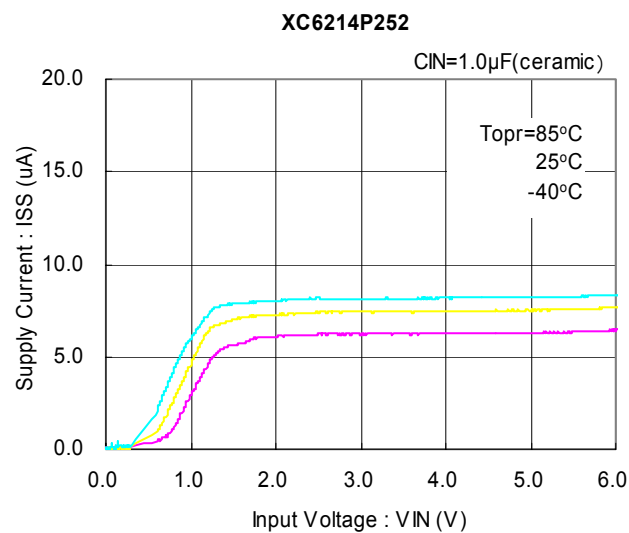
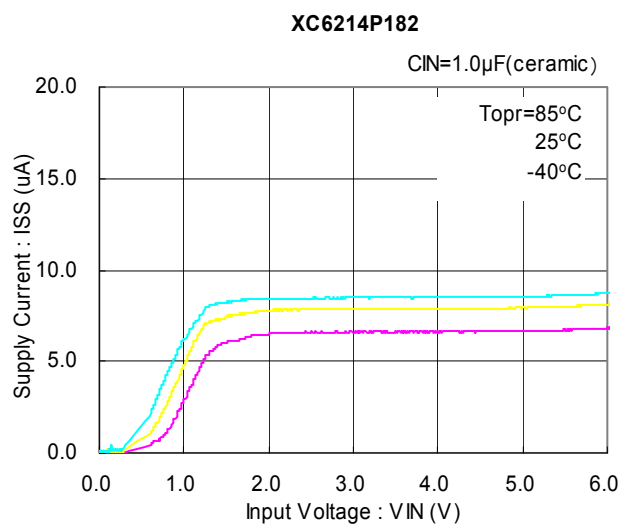
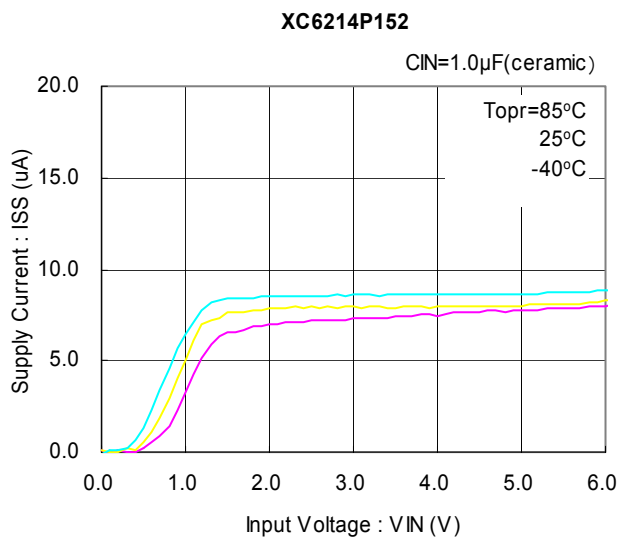



## TYPICAL PERFORMANCE CHARACTERISTICS (Continued)

(5) Output Voltage vs. Ambient Temperature

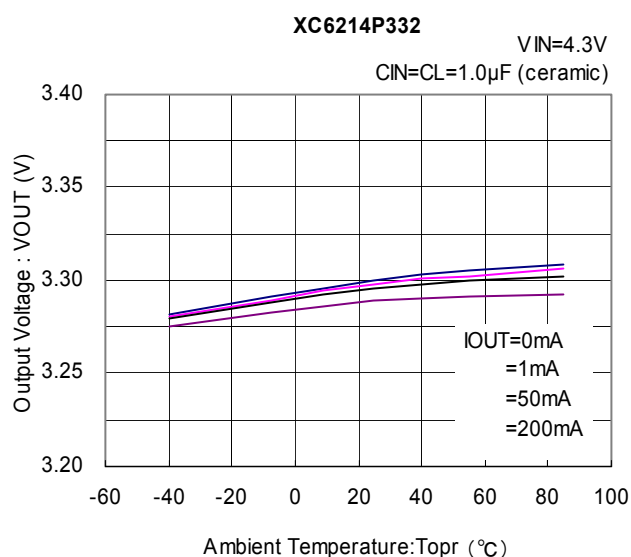
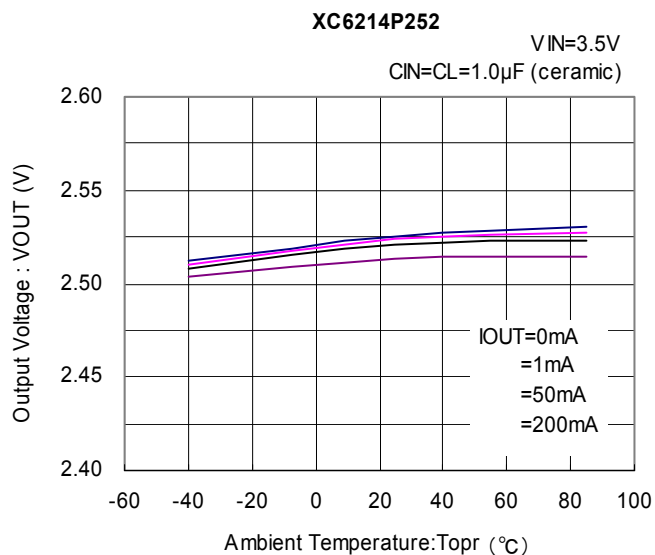
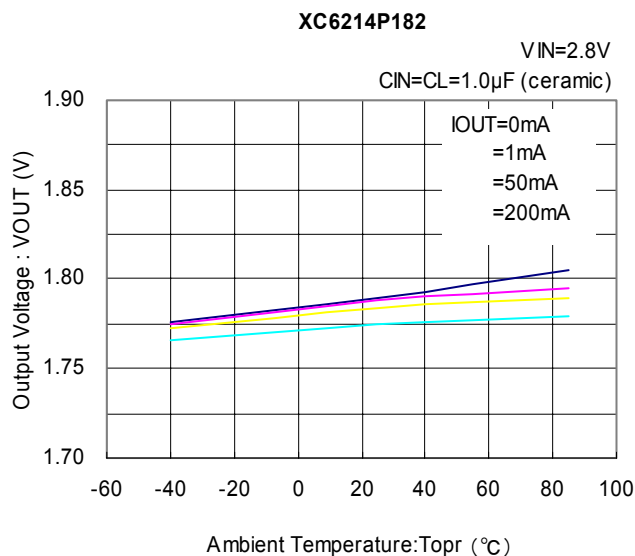
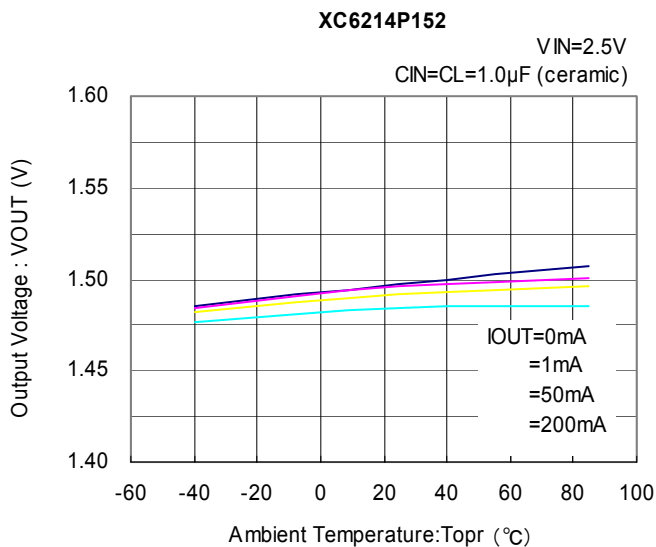

(6) Supply Current vs. Ambient Temperature

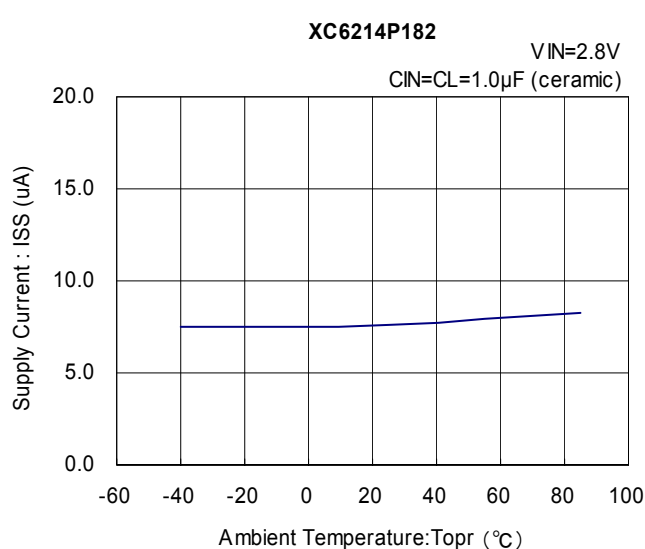
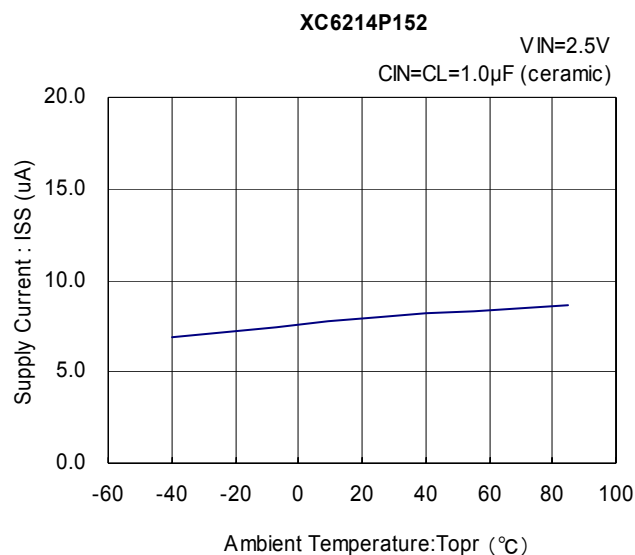

## ■ TYPICAL PERFORMANCE CHARACTERISTICS (Continued)

(6) Supply Current vs. Ambient Temperature (Continued)

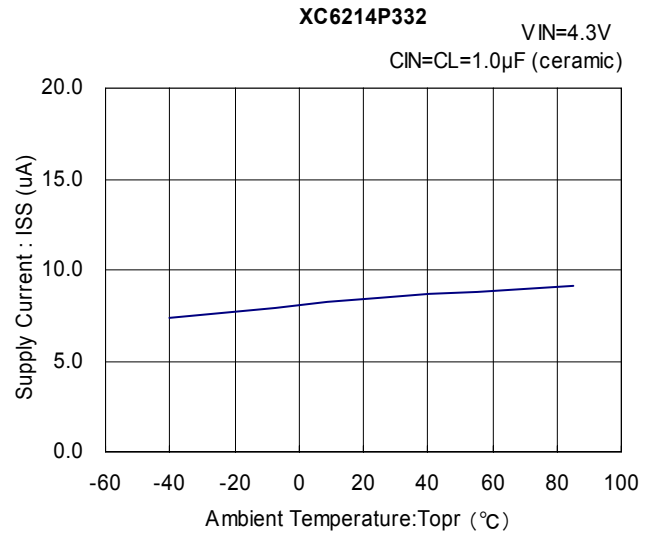
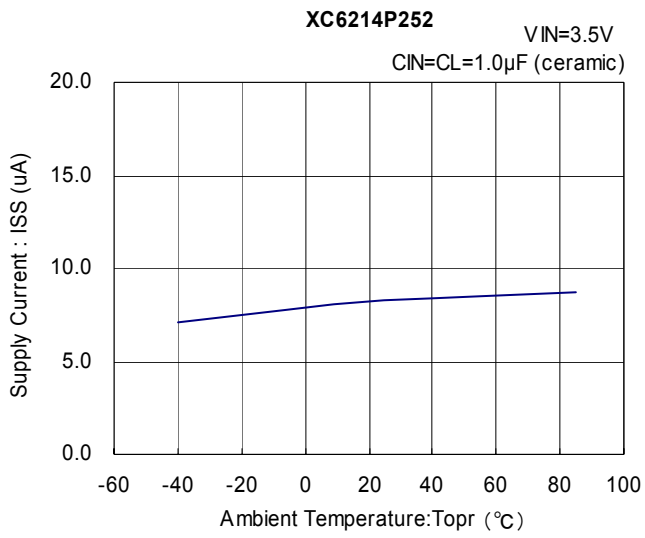

## ■ TYPICAL PERFORMANCE CHARACTERISTICS (Continued)

### (7) Input Transient Response

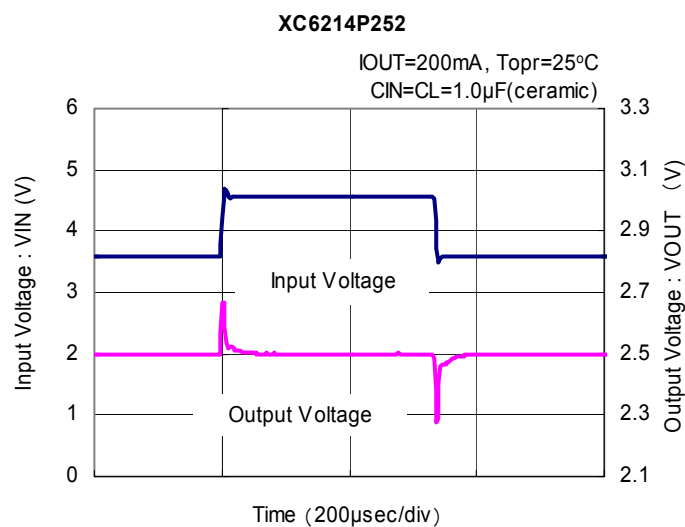
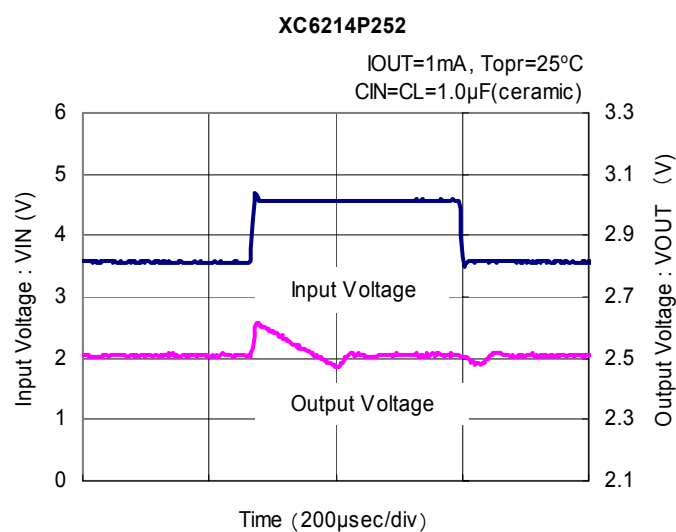
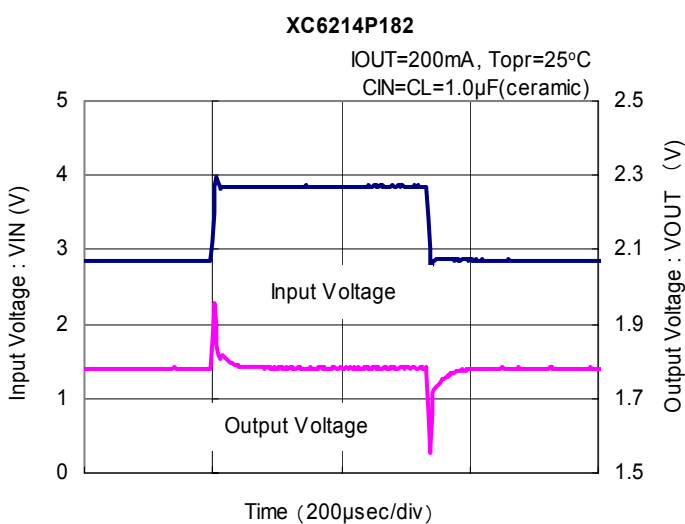
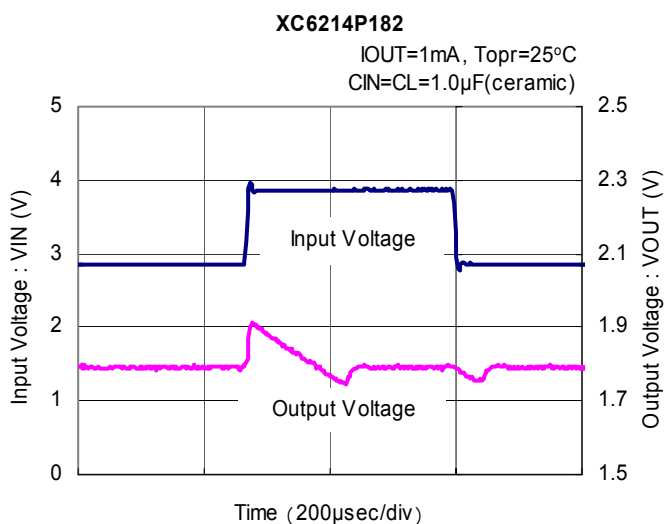
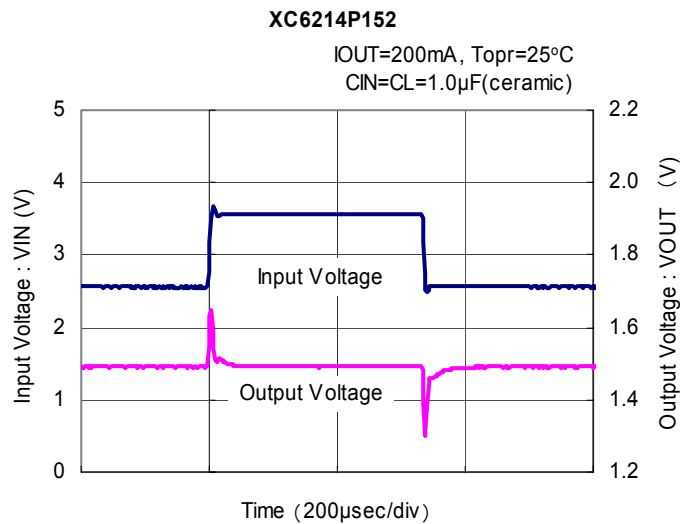
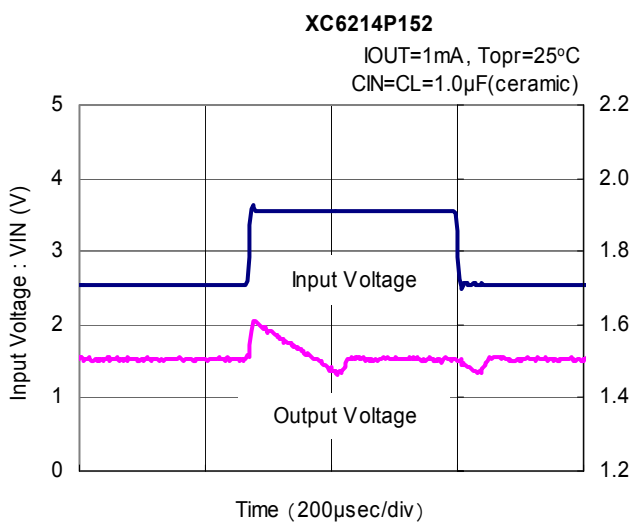

## TYPICAL PERFORMANCE CHARACTERISTICS (Continued)

(7) Input Transient Response (Continued)

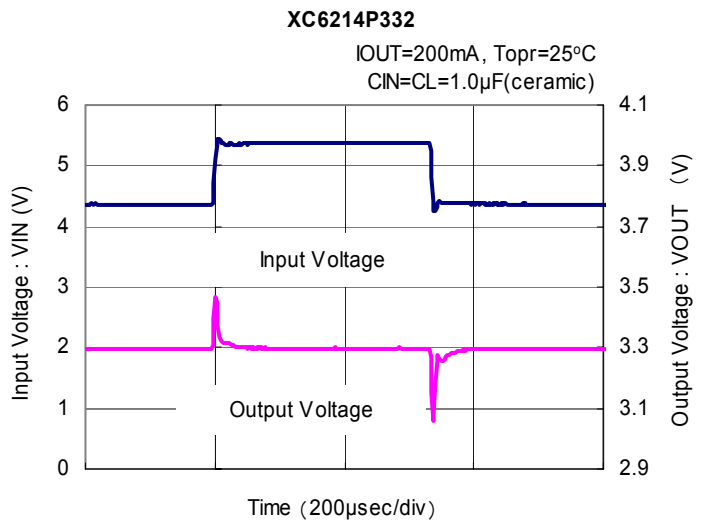
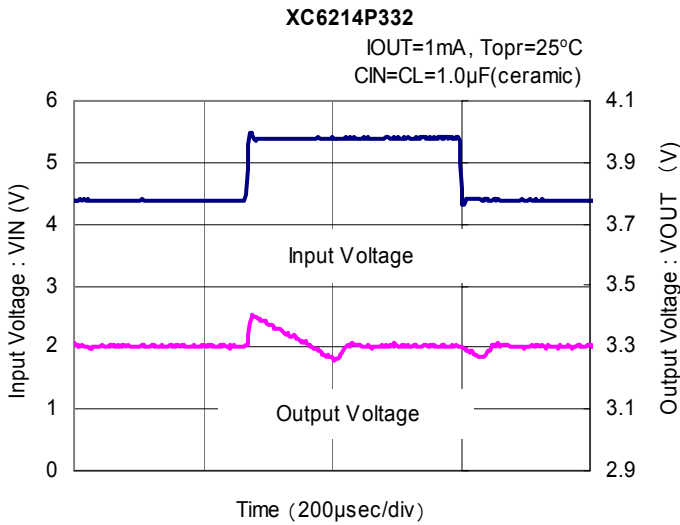

(8) Load Transient Response

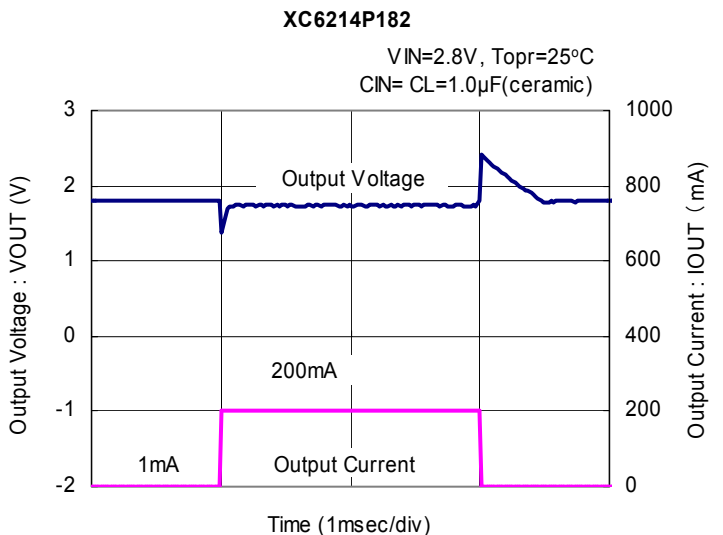
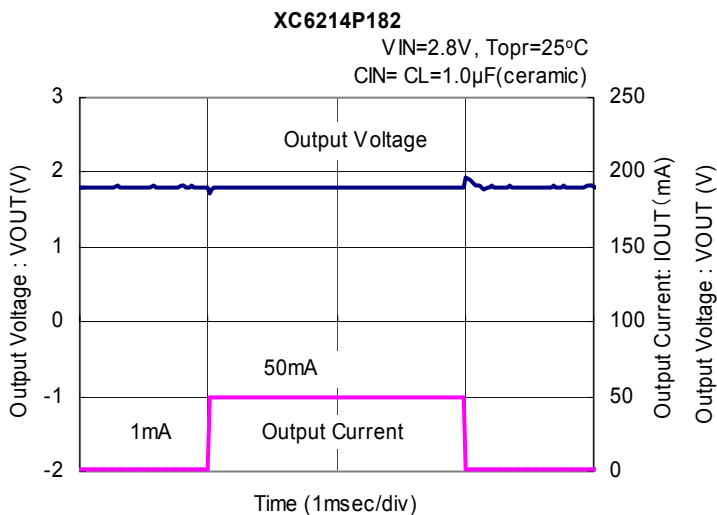
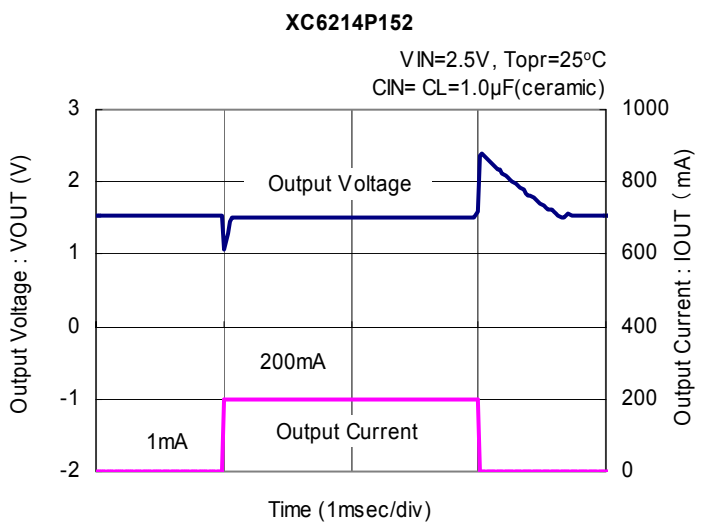
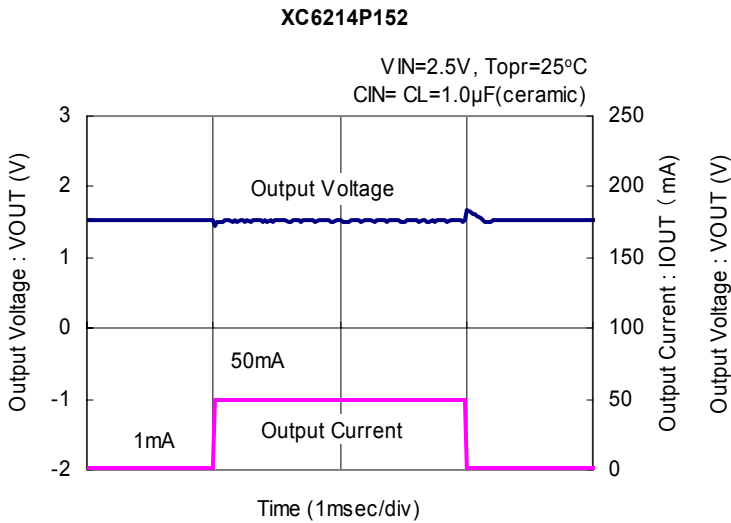

## ■ TYPICAL PERFORMANCE CHARACTERISTICS (Continued)

### (8) Load Transient Response (Continued)

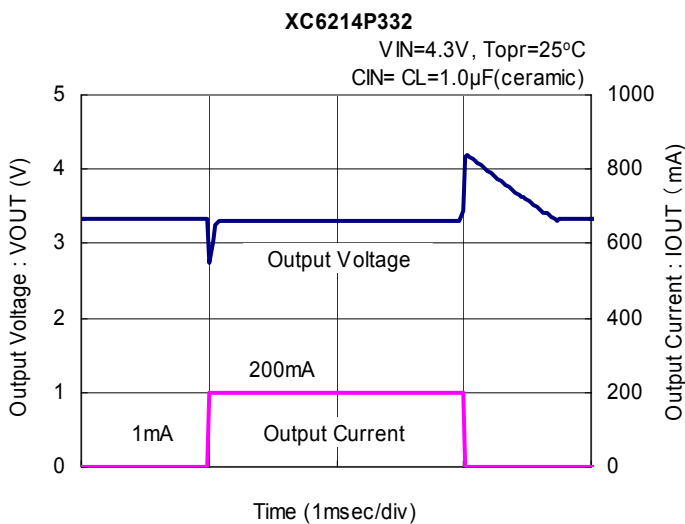
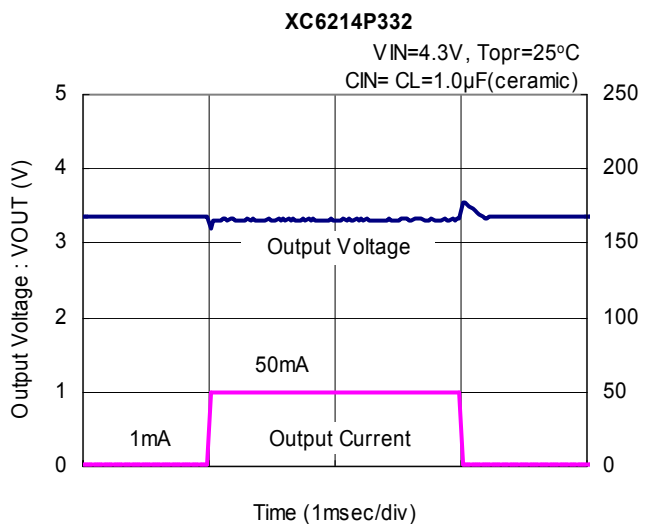
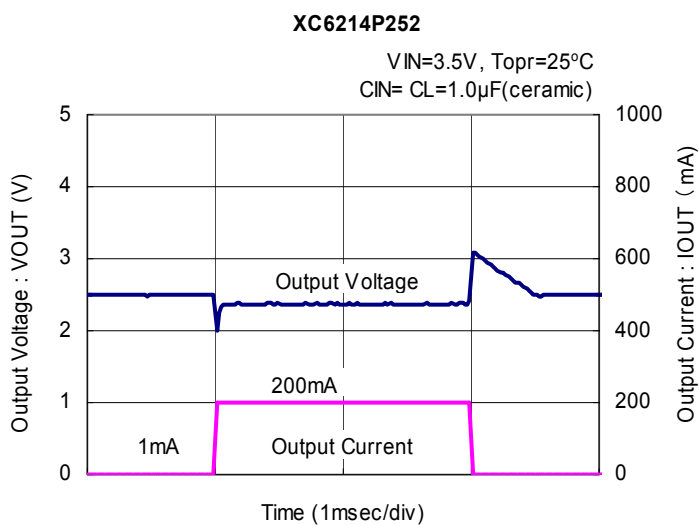
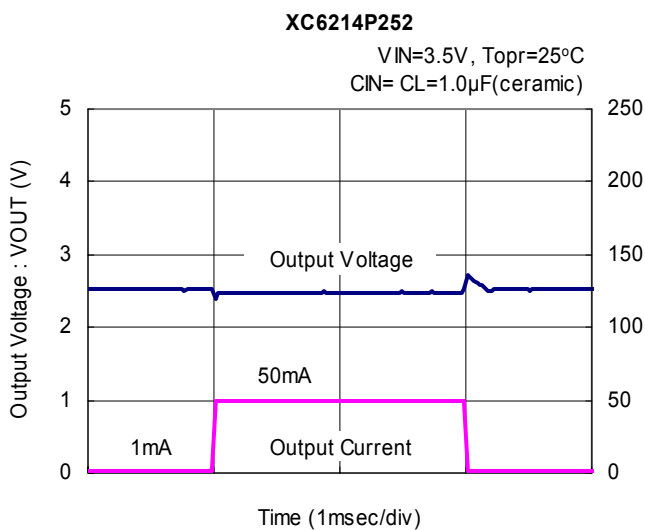

### (9) Ripple Rejection Rate

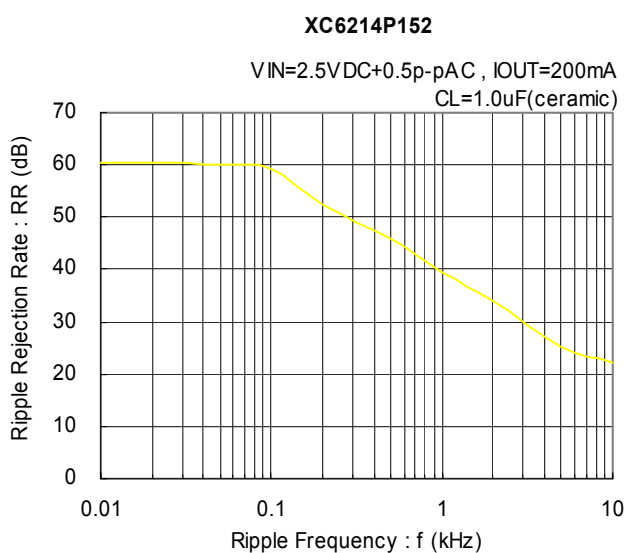
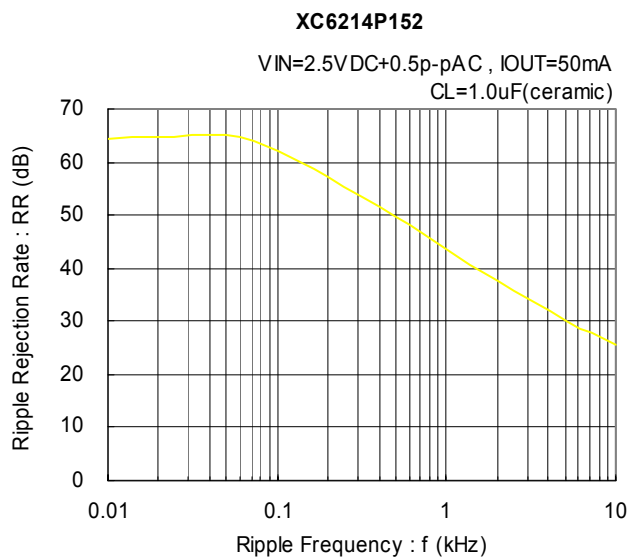

## TYPICAL PERFORMANCE CHARACTERISTICS (Continued)

### (9) Ripple Rejection Rate (Continued)

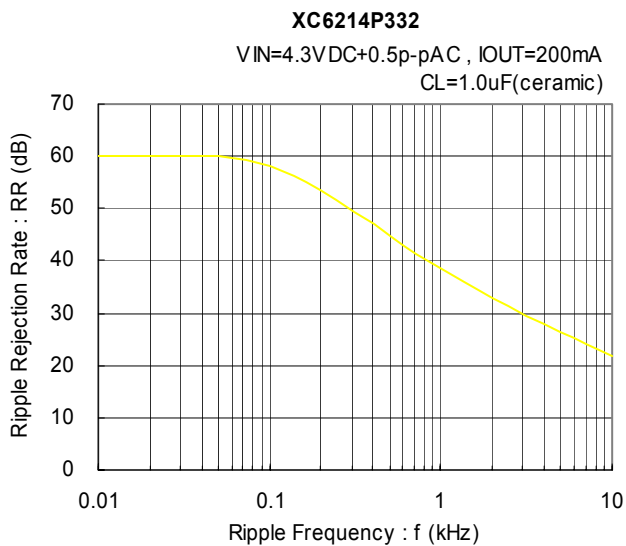
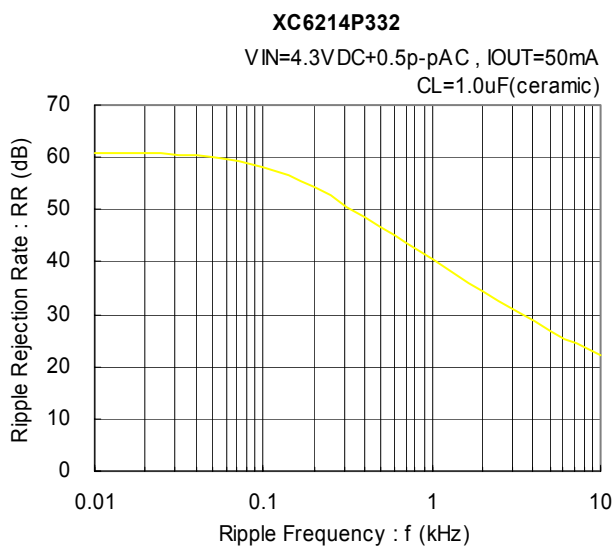
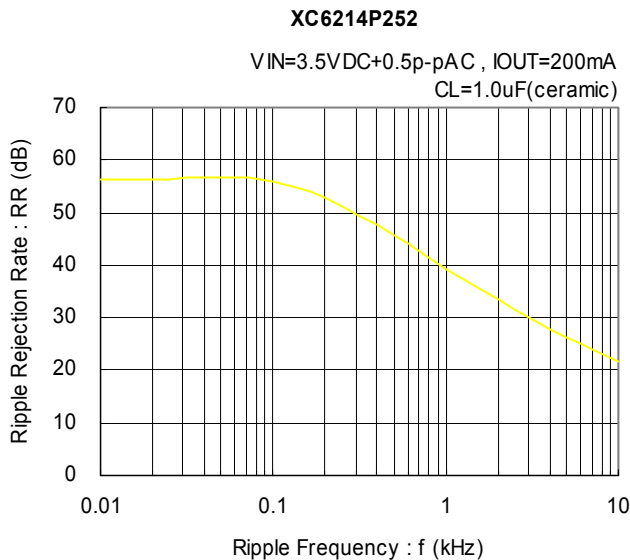
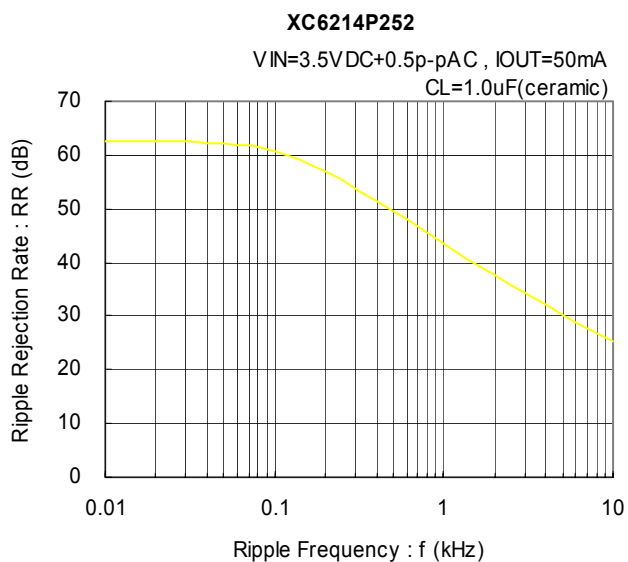
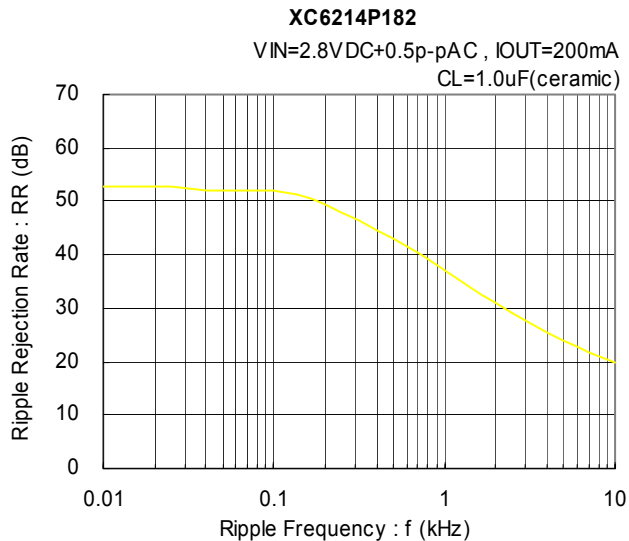
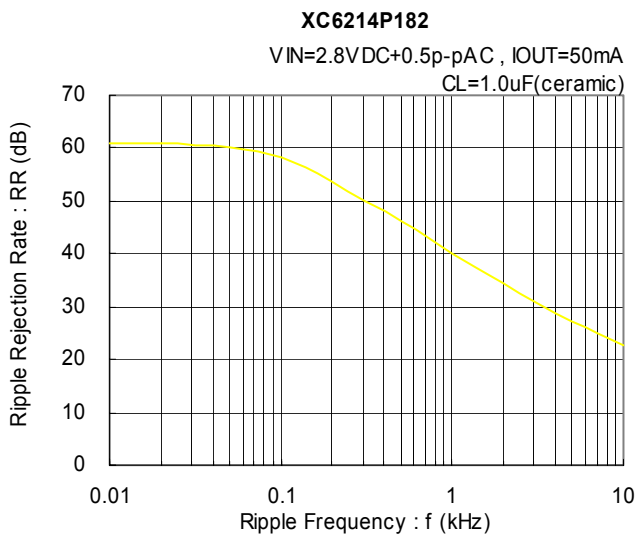

1. The products and product specifications contained herein are subject to change without notice to improve performance characteristics. Consult us, or our representatives before use, to confirm that the information in this catalog is up to date.
2. We assume no responsibility for any infringement of patents, patent rights, or other rights arising from the use of any information and circuitry in this catalog.
3. Please ensure suitable shipping controls (including fail-safe designs and aging protection) are in force for equipment employing products listed in this catalog.
4. The products in this catalog are not developed, designed, or approved for use with such equipment whose failure of malfunction can be reasonably expected to directly endanger the life of, or cause significant injury to, the user.  
(e.g. Atomic energy; aerospace; transport; combustion and associated safety equipment thereof.)
5. Please use the products listed in this catalog within the specified ranges.  
Should you wish to use the products under conditions exceeding the specifications, please consult us or our representatives.
6. We assume no responsibility for damage or loss due to abnormal use.
7. All rights reserved. No part of this catalog may be copied or reproduced without the prior permission of Torex Semiconductor Ltd.

**TOREX SEMICONDUCTOR LTD.**