

## Step-Down Switching Regulator with Current-Mode Control

### Features and Benefits

- Current-mode control system employed
- Excellent line regulation (60 mV maximum)
- 165 mΩ maximum on-resistance of built-in MOSFET
- Output current 3.5 A
- Wide range of input voltages (4.75 to 28 V), supports 24 V direct drive
- Output voltage 0.5 to 24 V, compatible with various IC power supply voltages, through low  $V_{REF}$  of 0.5 V.
- High efficiency, 94% maximum at  $V_{IN} = 8 V$ ,  $V_O = 5 V$ , and  $I_O = 0.5 A$
- Operating frequency 500 kHz, supports downsizing of smoothing choke coil
- Soft start and output on/off functions built-in
- Built-in protection:
  - Drooping overcurrent protection
  - Overtemperature protection
  - Undervoltage lockout (UVLO)

**Package: HSOP8 surface mount with exposed thermal pad**

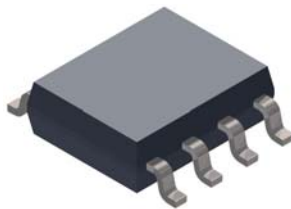

Not to scale

### Description

The SI-8005Q is a step-down switching regulator IC, designed as an output voltage regulator at the secondary stage of switch mode power supplies. The current-mode control system permits small ceramic capacitors to be used as output capacitors. Together with the compact HSOP8 package, this allows reduction of regulator circuitry area on the PCB by approximately 50% in comparison with conventional topologies.

Designed to save power, losses in the SI-8005Q are reduced by controlling the maximum on-resistance of a built-in output MOSFET to as low as 165 mΩ. Furthermore, die miniaturization has been accomplished through a proprietary BCD process.

The SI-8005Q supplies an output current of 3.5 A and an output voltage that is variable from 0.5 to 24 V, which is easily set to a voltage compatible with the diverse reduced power supply voltages required by signal processing ICs. Accepting a wide input voltage range, from 4.75 to 28 V, the SI-8005Q can be driven directly by a 24 V power supply.

Applications include power supplies for signal processing ICs for memories and microcomputers used in plasma display panel (PDP) TVs, liquid crystal display (LCD) TVs, computer hard drives, and DVD recorders.

### Functional Block Diagram

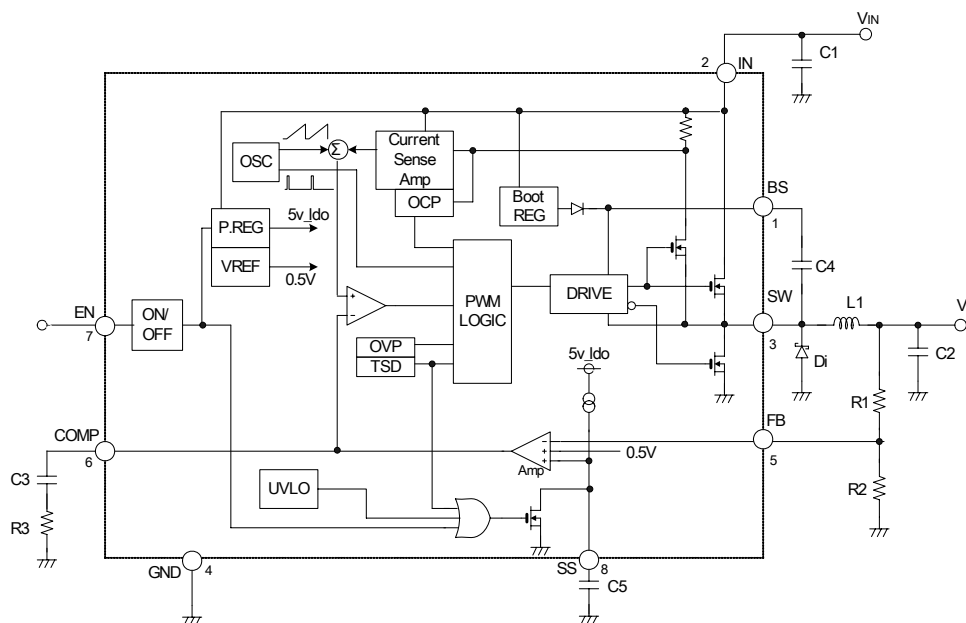

## Selection Guide

Part Number	Packing
SI8005Q-TL	1000 pieces per reel

## Absolute Maximum Ratings

Characteristic	Symbol	Remarks	Rating	Unit
DC Input Voltage	$V_{IN}$		30	V
DC Input Voltage	$V_{EN}$		6	V
Allowable Power Dissipation	$P_D$	Limited by internal thermal shutdown, mounted on a 30 mm × 30 mm glass epoxy PCB with 25 mm × 25 mm exposed copper area, $T_J(\text{max}) = 125^\circ\text{C}$	1.35	W
Junction Temperature	$T_J$	Internal thermal shutdown activates at approximately $140^\circ\text{C}$	-30 to 150	$^\circ\text{C}$
Storage Temperature	$T_{stg}$		-40 to 150	$^\circ\text{C}$
Thermal Resistance (Junction to Ambient)	$R_{\theta JA}$	Mounted on a 30 mm × 30 mm glass epoxy PCB with 25 mm × 25 mm exposed copper area	74	$^\circ\text{C/W}$
Thermal Resistance (Junction to Case)	$R_{\theta JC}$		40	$^\circ\text{C/W}$

## Recommended Operating Conditions\*

Characteristic	Symbol	Remarks	Min.	Typ.	Max.	Units
DC Input Voltage Range	$V_{IN}$	$V_{IN}(\text{min})$ is the greater of either 4.75 V or $V_O + 1$ V; except if $V_O + 0.5 \leq V_{IN} \leq V_O + 1$ V, then $V_{IN}(\text{min})$ is set such that $I_O \leq 2$ A	See remarks	-	28	V
DC Output Current Range	$I_O$	Using the circuit defined in the Typical Application diagram and within $P_D$ limits	0	-	3.5	A
Operating Junction Temperature Range	$T_{JOP}$		-30	-	125	$^\circ\text{C}$
Operating Temperature Range	$T_{OP}$	Operation within $P_D$ limits	-30	-	85	$^\circ\text{C}$

\*Recommended operating range indicates conditions which are required for maintaining normal circuit functions shown in the Electrical Characteristics table.

## Maximum Allowable Package Power Dissipation

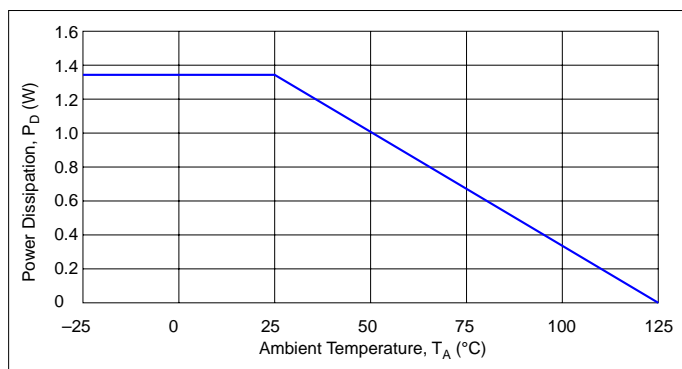

Results calculated as:

$$P_D = V_O \times I_O \left( \frac{100}{\eta x} - 1 \right) - V_F \times I_O \left( 1 - \frac{V_O}{V_{IN}} \right)$$

where:

$V_O$  is the output voltage,

$V_{IN}$  is the Input voltage (0.4 V for these results),

$I_O$  is the Output current (0.3 A for these results),

$\eta x$  is the efficiency (%), which varies with  $V_{IN}$  and  $I_O$  (derived from the Efficiency curves in the Characteristic Performance section), and

$V_F$  is the diode forward voltage for D1, determination of the value for D1 should be made based on testing with the actual application (Sanken diode SJPB-D4 was used for these results).

All performance characteristics given are typical values for circuit or system baseline design only and are at the nominal operating voltage and an ambient temperature,  $T_A$ , of  $25^\circ\text{C}$ , unless otherwise stated.

### ELECTRICAL CHARACTERISTICS<sup>1</sup>, valid at T<sub>A</sub>=25°C, unless otherwise noted

Characteristics	Symbol	Conditions	Min	Typ	Max	Units
Reference Voltage	V <sub>REF</sub>	V <sub>IN</sub> = 12 V, I <sub>O</sub> = 1.0 A	0.485	0.500	0.515	V
Output Voltage Temperature Coefficient	ΔV <sub>REF</sub> /ΔT	V <sub>IN</sub> = 12 V, I <sub>O</sub> = 1.0 A, T <sub>A</sub> = -40°C to 85°C	-	±0.05	-	mV/°C
Efficiency <sup>2</sup>	η	V <sub>IN</sub> = 12 V, V <sub>O</sub> = 5 V, I <sub>O</sub> = 1 A	-	90	-	%
Operating Frequency	f <sub>O</sub>	V <sub>IN</sub> = 16 V, V <sub>O</sub> = 5 V, I <sub>O</sub> = 1 A	450	500	550	kHz
Line Regulation	V <sub>LINE</sub>	V <sub>IN</sub> = 8 to 28 V, V <sub>O</sub> = 5 V, I <sub>O</sub> = 1 A	-	10	60	mV
Load Regulation	V <sub>LOAD</sub>	V <sub>IN</sub> = 12 V, V <sub>O</sub> = 5 V, I <sub>O</sub> = 0.1 to 3.5 A	-	10	60	mV
Overcurrent Protection Threshold	I <sub>S</sub>	V <sub>IN</sub> = 12 V, V <sub>O</sub> = 5 V	3.6	-	6.0	A
Quiescent Current 1	I <sub>IN</sub>	V <sub>IN</sub> = 12 V, V <sub>O</sub> = 5 V, I <sub>O</sub> = 0 A, V <sub>EN</sub> = open	-	18	-	mA
Quiescent Current 2	I <sub>IN(off)</sub>	V <sub>IN</sub> = 12 V, V <sub>O</sub> = 5 V, I <sub>O</sub> = 0 A, V <sub>EN</sub> = 0 V	-	-	20	μA
SS Terminal Leakage Current <sup>3</sup>	I <sub>SSL</sub>	V <sub>SSL</sub> = 0 V, V <sub>IN</sub> = 16 V	-	5	-	μA
EN Terminal High Level Voltage	V <sub>CEH</sub>	V <sub>IN</sub> = 12 V	2.8	-	-	V
EN Terminal Low Level Voltage	V <sub>CEL</sub>	V <sub>IN</sub> = 12 V	-	-	2.0	V
EN Terminal Leakage Current	I <sub>CEH</sub>	V <sub>EN</sub> = 0 V	-	1	-	μA
Error Amplifier Voltage Gain	A <sub>EA</sub>		-	1000	-	V/V
Error Amplifier Transconductance	G <sub>EA</sub>		-	800	-	μA/V
Current Sense To COMP Transimpedance	1/G <sub>CS</sub>		-	0.35	-	V/A
Maximum Duty Cycle (On)	DC <sub>MAX</sub>		-	92	-	%
Minimum On-Time	t <sub>MIN</sub>		-	100	-	ns

<sup>1</sup>Using circuit shown in Measurement Circuit diagram.

<sup>2</sup>Efficiency is calculated as:  $\eta(\%) = ([V_O \times I_O] \div [V_{IN} \times I_{IN}]) \times 100$ .

<sup>3</sup>SS terminal enables soft start when a an external capacitor is connected to it. Because a pull-up resistor is provided inside the IC, no external voltage can be applied to this terminal.

Measurement Circuit Diagram

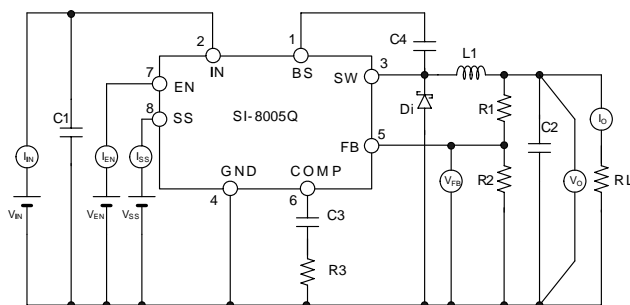

Component	Rating
C1	22 μF / 50 V
C2	47 μF / 25 V
C3	220 pF / 10 V
C4	10 nF / 25 V
Di	SPB-G56S
L1	10 μH
R1	46 kΩ
R2	5.1 kΩ
R3	62 kΩ

Performance Characteristics

at  $T_A = 25^\circ\text{C}$

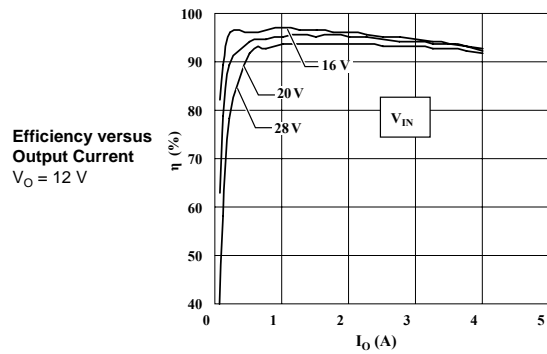
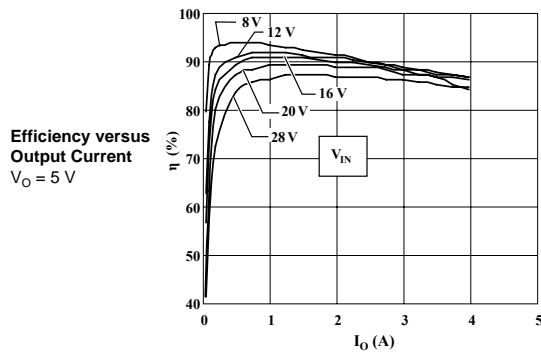
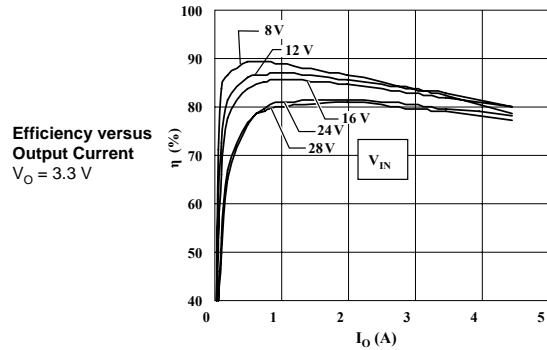
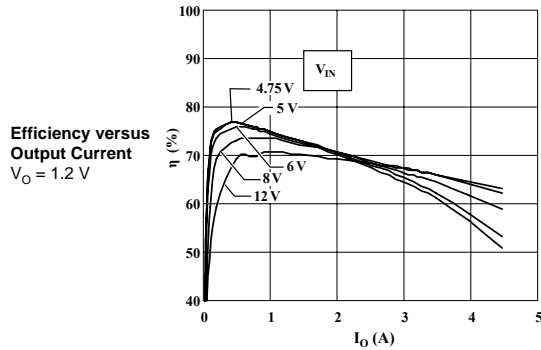

Performance Characteristics  
at  $T_A = 25^\circ\text{C}$

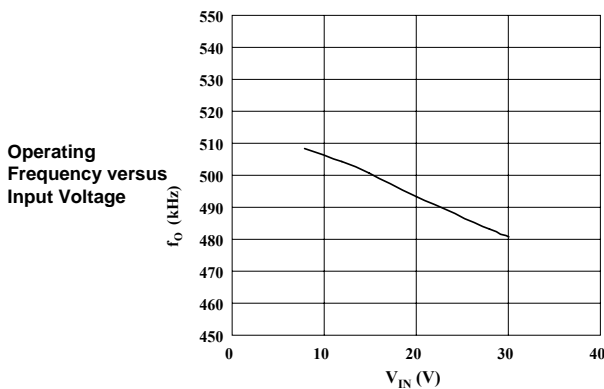
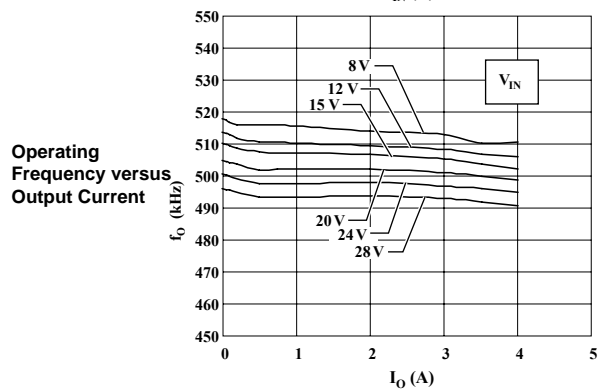
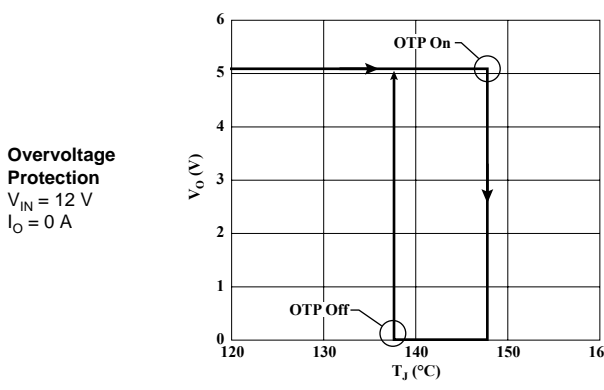
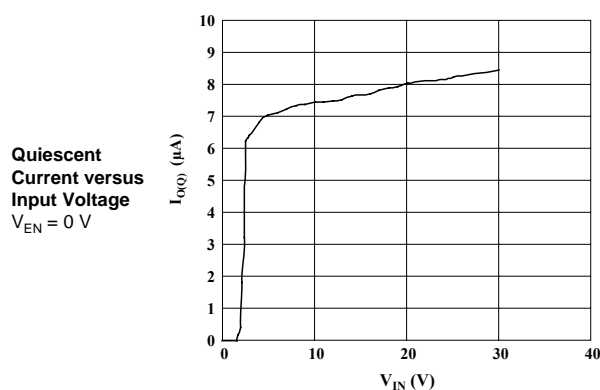
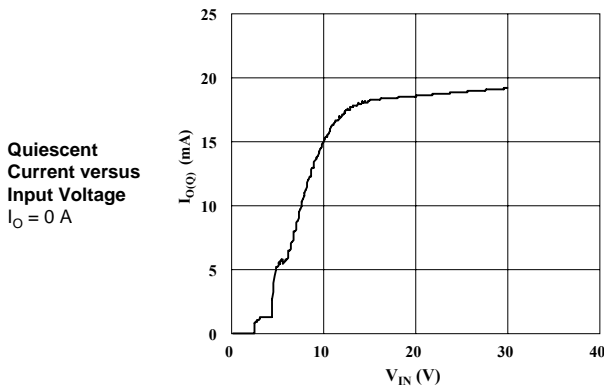
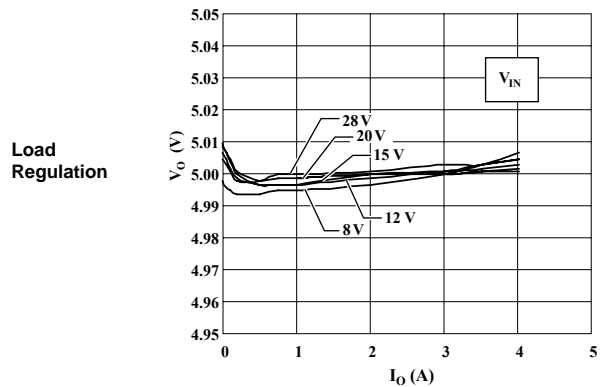
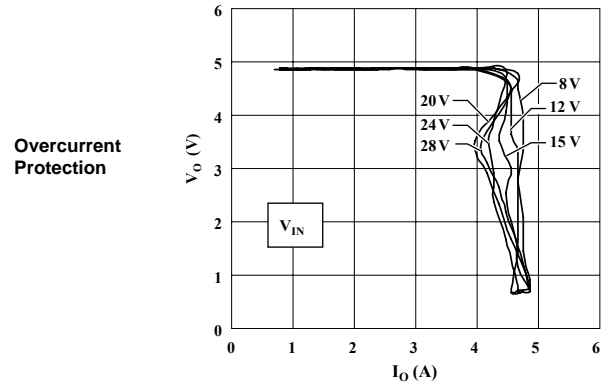
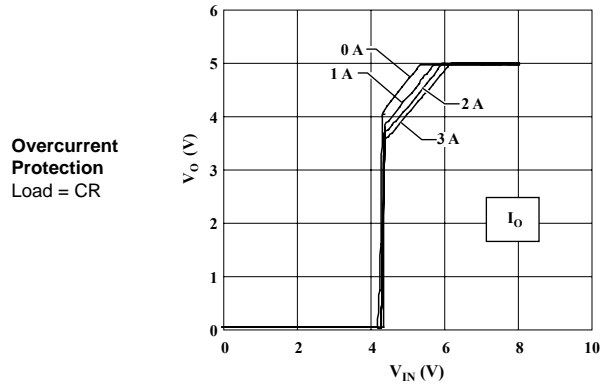

## Component Selection

**Diode Di** A Schottky-barrier diode must be used for Di. If other diode types, such as like fast recovery diodes, are used, the IC may be destroyed because of reverse voltages applied by the recovery voltage or turn-on voltage.

**Choke Coil L1** If the winding resistance of the choke coil is too high, IC efficiency may go down to the extent that the resistance is beyond the rating. Because the overcurrent protection threshold current is approximately 4 A, attention must be paid to the heating of the choke coil by magnetic saturation due to overload or short-circulated load.

**Capacitors C1, C2, and C5** Because large ripple currents for SMPS flow across C1 and C2, capacitors with high frequency and low impedance must be used. Especially when the impedance of C2 is high, the switching waveform may not be normal at low temperatures.

C5 is used to enable soft start. If the soft start function is not used, leave the SS terminal open.

**Resistors R1 and R2** R1 and R2 set the output voltage,  $V_O$ . Select the resistor values to set  $I_{ADJ}$  to 0.1 mA. R1 and R2 are calculated by the following expression:

$$R1 = \frac{(V_O - V_{FB})}{I_{ADJ}} = \frac{(V_O - 0.5)}{0.1 \times 10^{-3}} (\Omega) \quad R2 = \frac{V_{FB}}{I_{ADJ}} = \frac{0.5}{0.1 \times 10^{-3}} \approx 5k (\Omega)$$

For optimum performance, minimize the distance between components.

**Phase Compensation Components C3, C6, and R3** The stability and response of the loop is controlled through the COMP pin. The COMP pin is the output of the internal transconductance

Typical Application Diagram

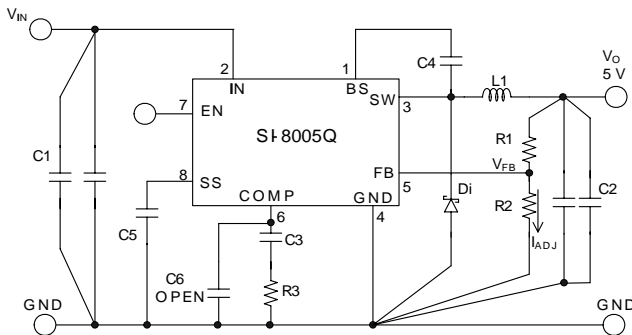

Component	Rating	Manufacturer
C1 (2 ea)	10 $\mu$ F / 50 V	Murata, P/N GRM55DB31H106KA87
C2 (2 ea)	22 $\mu$ F / 16 V	Murata, P/N GRM32ER71A226KE20
C3	220 pF	Murata, P/N GRM18 series
C4, C5	10 nF	Murata, P/N GRM18 series
Di		Sanken, P/N SPB-G56S or SJPB-L4
L1	10 $\mu$ H	
R1	46 k $\Omega$	
R2	5.1 k $\Omega$	
R3	62 k $\Omega$	

Recommended PCB Layout

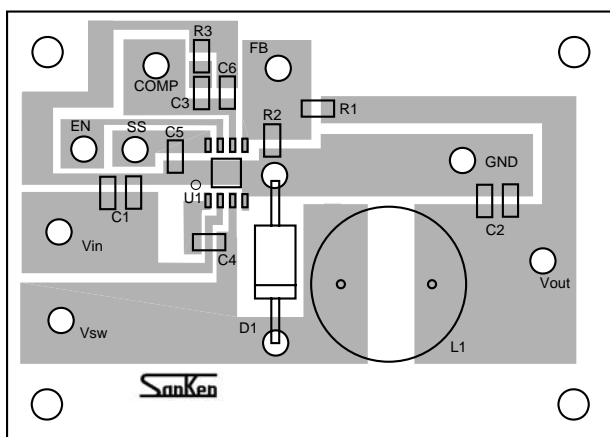

Recommended Solder Pad Layout

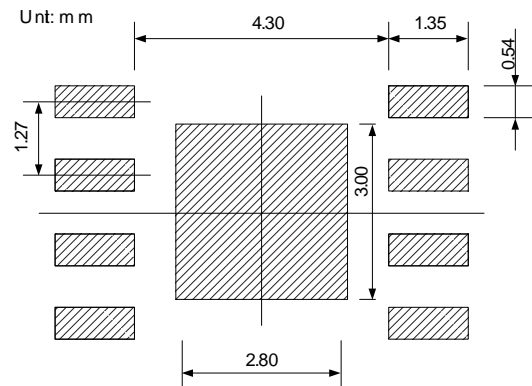

All external components should be mounted as closely as possible to the SI-8005Q. The ground of all components should be connected at one point. The exposed copper area on the PCB that is connected to the heat sink on the reverse side of package is ground. Enlarging the PCB copper area enhances thermal dissipation from the package.

amplifier. The combination of a series-connected capacitor and resistor sets the combination of a pole and zero frequency point that decide the characteristics of the control system. The DC gain of the voltage feedback loop is calculated by the following equation:

$$A_{dc} = R_l \times G_{CS} \times A_{EA} \times \frac{V_{FB}}{V_{out}}, \quad (1)$$

where

$V_{FB}$  is the feedback voltage (0.5 V),

$A_{EA}$  is the error amplifier voltage gain,

$G_{CS}$  is the current sense transconductance, and

$R_l$  is the load resistor value.

The system has two important poles. One is set by the phase compensation capacitor (C3) and the output resistor of the error amplifier. The other is set by the output capacitor and load resistor. These poles are calculated by the following equations:

$$fp1 = \frac{G_{EA}}{2\pi \times C3 \times A_{EA}}, \quad (2)$$

$$fp2 = \frac{1}{2\pi \times C2 \times R_l}, \quad (3)$$

where  $G_{EA}$  is the error amplifier transconductance.

The system has one important zero point. This is set by the phase compensation capacitor (C3) and phase compensation resistor (R3). The zero point is shown by the following equation:

$$fz1 = \frac{1}{2\pi \times C3 \times R3}. \quad (4)$$

If the value of the output capacitor is the large or if it has a high ESR, the system may have another important zero point. This zero point would be set by the ESR and capacitance of the output capacitor. The zero point is shown by the following equation:

$$f_{ESR} = \frac{1}{2\pi \times C2 \times RESR}. \quad (5)$$

In this case a third pole, which is set by the phase compensation capacitor (C6) and phase compensation resistor (R3), is used to compensate the effect of the ESR zero point on the loop gain. The pole is shown by the following equation:

$$fp3 = \frac{1}{2\pi \times C6 \times R3}. \quad (6)$$

The goal of phase compensation design is to shape the converter transfer function to get the required loop gain. The system crossover frequency, where the feedback loop has unity gain, is important. Lower crossover frequencies result in slower line and load transient responses. On the other hand, higher crossover frequencies cause system instability. A good standard is to adjust the crossover frequency to approximately one-tenth of the switching frequency.

The optimal selection of phase compensation components can be determined using the following procedure:

1. Choose the phase compensation resistor (R3) to adjust the required crossover frequency. R3 value is calculated by the following equation:

$$R3 = \frac{2\pi \times C2 \times f_c \times V_{out}}{G_{EA} \times G_{CS}} < \frac{2\pi \times C2 \times 0.1 \times f_s \times V_{out}}{G_{EA} \times G_{CS} \times V_{FB}}, \quad (7)$$

where  $f_c$  is the required crossover frequency. This is usually adjusted to less than one-tenth of the switching frequency.

2. Choose the phase compensation capacitor (C3) to get the required phase margin. For applications that have typical inductor values, adjusting the compensation zero point to less than one-quarter of crossover frequency provides sufficient phase margin.

The value of C3 is calculated by the following equation:

$$C3 > \frac{4}{2\pi \times R3 \times f_c}, \quad (8)$$

where R3 is the phase compensation resistor.

3. It is necessary to determine whether a second compensation capacitor (C6) is required. It is required if the ESR zero point of the output capacitor is less than half of the switching frequency, expressed as follows:

$$\frac{1}{2\pi \times C2 \times RESR} < \frac{f_s}{2}. \quad (9)$$

If this is the case, add the second compensation capacitor (C6) and adjust ESR zero frequency ( $f_{p3}$ ). C6 value is calculated by the following equation:

$$C6 = \frac{C2 \times RESR}{R3}. \quad (10)$$

Package Outline Drawing

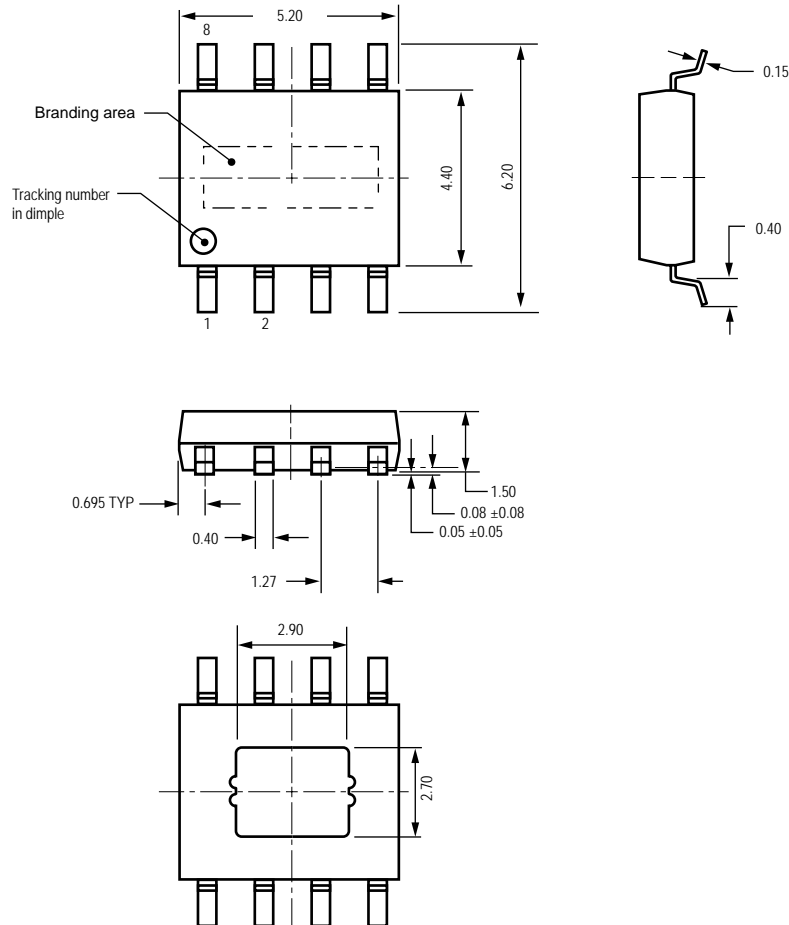

Dimensions in millimeters

Branding codes (exact appearance at manufacturer discretion):

1st line, type: 8005Q

2nd line, lot: SK YMDD

Where: Y is the last digit of the year of manufacture

M is the month (1 to 9, O, N, D)

DD is the date

3rd line, control: NNNN



Leadframe plating Pb-free. Device composition complies with the RoHS directive.





### Cautions

In general, the junction temperature level of surface mount package ICs is dependent upon the area and material of the PC board and its copper area. Therefore, please design the PCB to allow sufficient margin for heat dissipation.

**Parallel Operation** Parallel operation of multiple products to increase the current is not allowed.

**Thermal Shutdown** The SI-8000Q series has a thermal protection circuit. This circuit keeps the IC from the damage by overload. But this circuit cannot guarantee the long-term reliability against the continuous overload conditions.

**ESD Susceptibility** Take precautions against damage by static electricity.

---

*The products described herein are manufactured in Japan by Sanken Electric Co., Ltd. for sale by Allegro MicroSystems, Inc.*

*Sanken and Allegro reserve the right to make, from time to time, such departures from the detail specifications as may be required to permit improvements in the performance, reliability, or manufacturability of its products. Therefore, the user is cautioned to verify that the information in this publication is current before placing any order.*

*When using the products described herein, the applicability and suitability of such products for the intended purpose shall be reviewed at the users responsibility.*

*Although Sanken undertakes to enhance the quality and reliability of its products, the occurrence of failure and defect of semiconductor products at a certain rate is inevitable.*

*Users of Sanken products are requested to take, at their own risk, preventative measures including safety design of the equipment or systems against any possible injury, death, fires or damages to society due to device failure or malfunction.*

*Sanken products listed in this publication are designed and intended for use as components in general-purpose electronic equipment or apparatus (home appliances, office equipment, telecommunication equipment, measuring equipment, etc.). Their use in any application requiring radiation hardness assurance (e.g., aerospace equipment) is not supported.*

*When considering the use of Sanken products in applications where higher reliability is required (transportation equipment and its control systems or equipment, fire- or burglar-alarm systems, various safety devices, etc.), contact a company sales representative to discuss and obtain written confirmation of your specifications.*

*The use of Sanken products without the written consent of Sanken in applications where extremely high reliability is required (aerospace equipment, nuclear power-control stations, life-support systems, etc.) is strictly prohibited.*

*The information included herein is believed to be accurate and reliable. Application and operation examples described in this publication are given for reference only and Sanken and Allegro assume no responsibility for any infringement of industrial property rights, intellectual property rights, or any other rights of Sanken or Allegro or any third party that may result from its use.*

Copyright © 2007 Allegro MicroSystems, Inc.

# SI-8005Q

January, 2008

---

## <Worldwide Contacts>

### Asia Pacific

#### China

##### **Sanken Electric Hong Kong Co., Ltd.**

Suite 1026 Ocean Centre, Canton Road, Tsimshatsui, Kowloon, Hong Kong

Tel: 852-2735-5262

Fax: 852-2735-5494

##### **Sanken Electric (Shanghai) Co., Ltd.**

Room3202, Maxdo Centre, Xingyi Road 8, Changning district, Shanghai, China

Tel: 86-21-5208-1177

Fax: 86-21-5208-1757

##### **Taiwan Sanken Electric Co., Ltd.**

Room 1801, 18th Floor, 88 Jung Shiau East Road, Sec. 2, Taipei 100, Taiwan R.O.C.

Tel: 886-2-2356-8161

Fax: 886-2-2356-8261

#### India

##### **Saket Devices Pvt. Ltd.**

Office No.13, First Floor, Bandal - Dhankude Plaza, Near PMT Depot, Paud Road, Kothrud, Pune - 411 038, India

Tel: 91-20-5621-2340

91-20-2528-5449

Fax: 91-20-2528-5459

#### Japan

##### **Sanken Electric Co., Ltd. Overseas Sales Headquarters**

Metropolitan Plaza Bldg. 1-11-1 Nishi-Ikebukuro, Toshima-ku, Tokyo 171-0021, Japan

Tel: 81-3-3986-6164

Fax: 81-3-3986-8637

#### Korea

##### **Sanken Electric Korea Co., Ltd.**

Mirae Asset Life Bldg. 6F, 168 Kongduk-dong, Mapo-ku, Seoul, 121-705, Korea

Tel: 82-2-714-3700

Fax: 82-2-3272-2145

#### Singapore

##### **Sanken Electric Singapore Pte. Ltd.**

150 Beach Road, #14-03 The Gateway West, Singapore 189720

Tel: 65-6291-4755

Fax: 65-6297-1744

# SI-8005Q

January, 2008

---

## Europe

### United Kingdom

**Sanken Power Systems (UK) Limited**

Pencoed Technology Park Pencoed, Bridgend CF35 5HY. UK

Tel: 44-1656-869-100

Fax: 44-1656-869-162

## North America

### United States

**Allegro MicroSystems, Inc.**

115 Northeast Cutoff, Worcester, Massachusetts 01606, U.S.A.

Tel: 1-508-853-5000

Fax: 1-508-853-3353

**Allegro MicroSystems, Inc. (Southern California)**

14 Hughes Street, Suite B105, Irvine, CA 92618

Tel: 1-949-460-2003

Fax: 1-949-460-7837