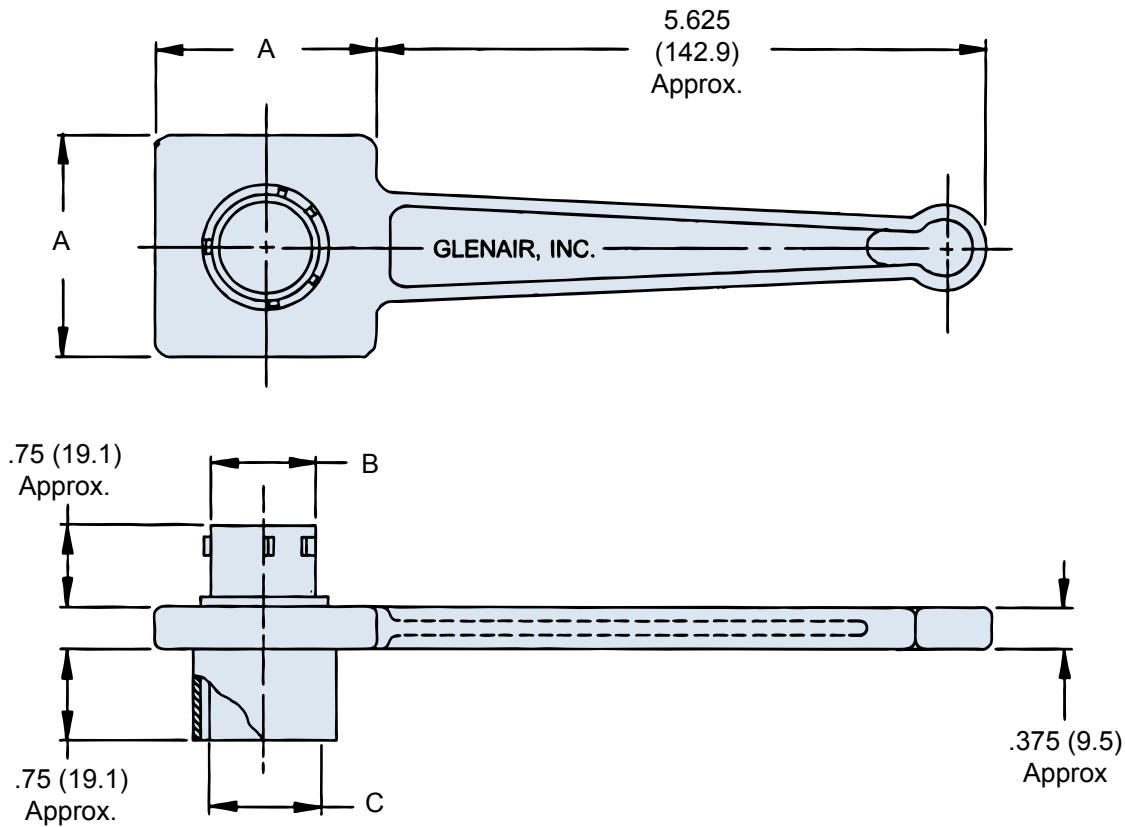

TG52

- 14

1

Basic Part  
NumberShell  
SizePolarization  
1, 2, 3, 4, 5, 6  
(Omit for Normal)

Shell Size	A Dim. ± .062 (1.6)	B Dia. Ref.	C Dia. Ref.
8	1.250 (31.8)	.382 (9.7)	.386 (9.8)
10	1.250 (31.8)	.507 (12.9)	.511 (13.0)
14	2.000 (50.8)	.757 (19.2)	.761 (19.3)
16	2.000 (50.8)	.883 (22.4)	.887 (22.5)
18	2.000 (50.8)	1.007 (25.6)	1.011 (25.7)

## APPLICATION NOTES

1. Metric dimensions (mm) are indicated in parentheses.
2. Material: Aluminum alloy with electroless nickel finish.