

# IPT 06 GSE Straight Plug Connector with Shrinkboot Backshell

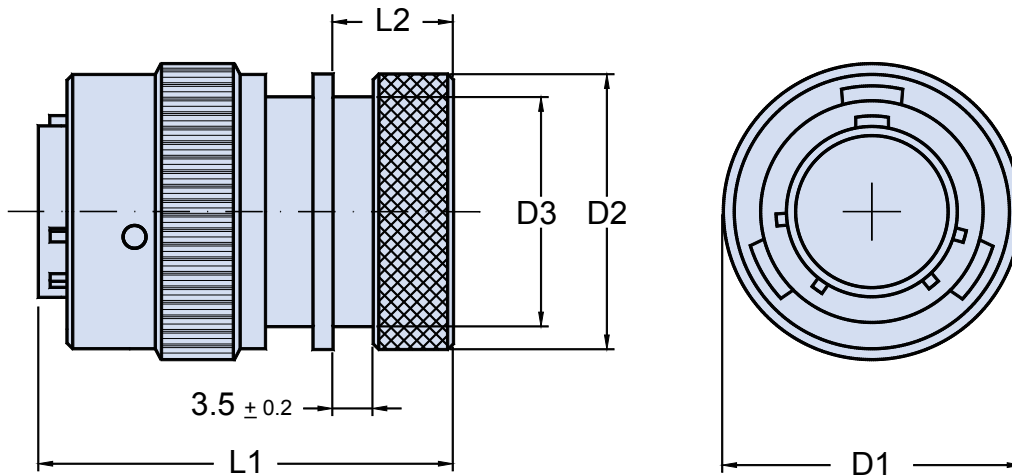
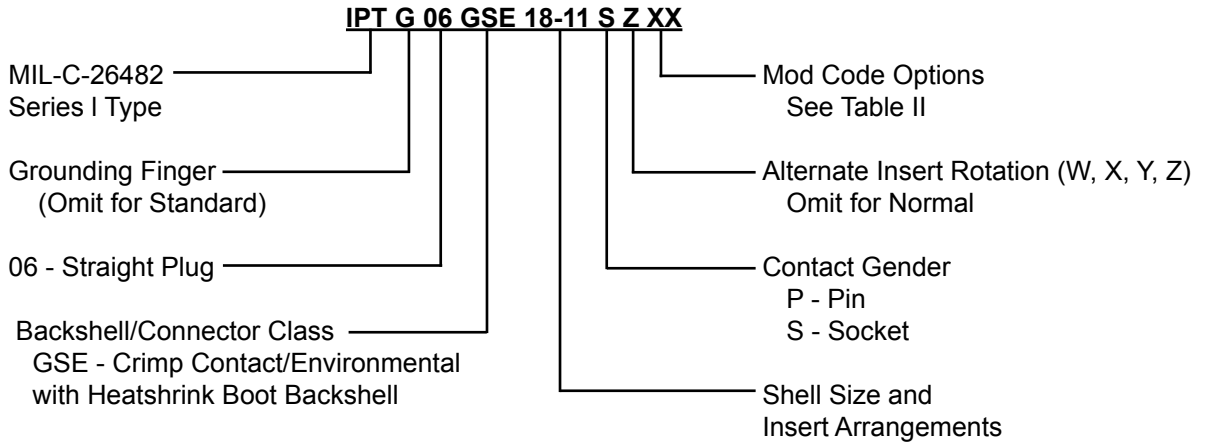

### APPLICATION NOTES

1. Straight plug with backshell suitable for heat shrink boot; Environmental, connector includes wire sealing grommet.
2. Connector Class "GSE" (crimp contact/environmental).
3. Standard materials configuration consists of aluminum alloy with stainless steel coupling pins.
4. Standard contact material consists of copper alloy with gold plating over nickel.
5. A broad range of other front and rear connector accessories are available. See our website and/or contact factory for complete information.
6. Standard insert is high insulation synthetic rubber.

# IPT 06 GSE Straight Plug Connector with Shrinkboot Backshell



IPT SE Series  
Bayonet Lock  
Connectors

**TABLE I: DIMENSIONS**

Shell size	D1 Max.	D2 + 0 - 0.5	D3 + 0 - 0.5	L1 Max.	L2 ± 0.5	Maximum Weight in Grams
8	19.8	15.6	13.3	39	12.2	14
10	23.5	18.4	16.1	39	12.2	16
12	26.5	23.7	21.4	39	12.2	23
14	30.0	24.5	22.2	39	12.2	30
16	33.1	29.8	26.2	39	14.5	43
18	35.3	32.0	28.5	39	14.5	46
20	38.8	36.1	32.5	44	15.8	63
22	42.0	38.5	34.8	44	15.8	78
24	45.1	41.6	37.9	44	14.9	84

**TABLE II: MODIFICATION CODES**

Shell Finish (Omit for Standard Cad/Olive Drab Finish)	Assembly with Accessories (Omit for Standard Version)
<b>F2</b> - Bright Nickel Plating (RoHs)	Key Polarization (Omit for <b>N</b> version) <b>W, X, Y, Z</b> = Alternates
<b>F6</b> - Black Electrodeposited Paint (RoHs)	<b>N0</b> - Connector Less Backshell
<b>F7</b> - Black Zn-Co Plating (RoHs)	<b>GXXX</b> - Custom Designed Connector
<b>F8</b> - Olive Drab Zn-Co Plating	

**STANDARD FINISHES (For QQ-A-591 Aluminum Shells)**

Requirements	IAW RoHS			Not IAW RoHS	
	F2 Electrolytic Nickel	F6 Black Non Conductive	F7 Black Conductive	G3 Cadmium with Olive Drab Passivation	F8 Zinc Cobalt with Olive Drab Passivation
Thermal Shock	-40°C + 100°C	-55°C + 125°C	-55°C + 125°C	-55°C + 125°C	-40°C + 100°C
Salt Spray After Thermal Shock	24 hour	500 hour	500 hour	500 hour	200 hour
Electical Conductivity	Very Good	NO	Very Good	Very Good	Good
Abrasion Resistance	Very Good	Very Good	Good	Very Good	Good