

**Silicon NPN Power Transistors**

**2SC2371**

**DESCRIPTION**

- With TO-126 package
- High Voltage
- High frequency

**APPLICATIONS**

- For TV chroma output and vertical output applications

**PINNING**

PIN	DESCRIPTION
1	Emitter
2	Collector
3	Base

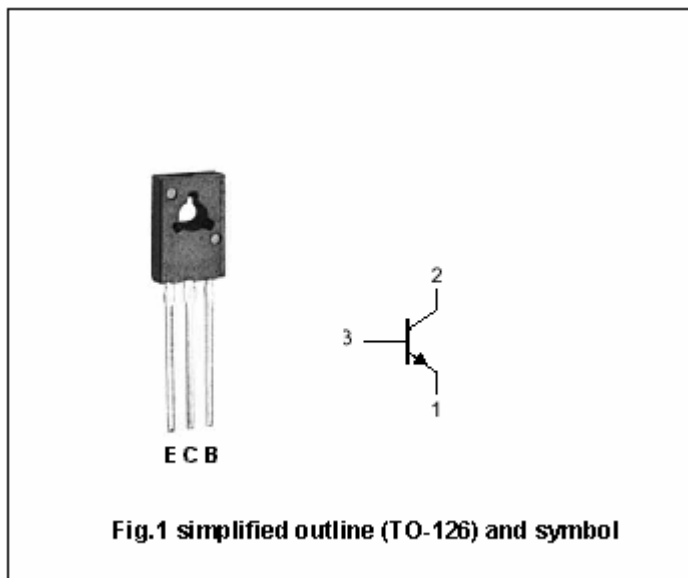

**Absolute maximum ratings (Ta=25 )**

SYMBOL	PARAMETER	CONDITIONS	VALUE	UNIT
V <sub>CBO</sub>	Collector-base voltage	Open emitter	300	V
V <sub>CEO</sub>	Collector-emitter voltage	Open base	300	V
V <sub>EBO</sub>	Emitter-base voltage	Open collector	6	V
I <sub>C</sub>	Collector current		0.1	A
I <sub>CM</sub>	Collector current-peak		0.2	A
P <sub>C</sub>	Collector power dissipation	T <sub>a</sub> =25	1.25	W
		T <sub>C</sub> =25	10	
T <sub>j</sub>	Junction temperature		150	
T <sub>stg</sub>	Storage temperature		-40~150	

## Silicon NPN Power Transistors

## 2SC2371

## CHARACTERISTICS

T<sub>j</sub>=25 unless otherwise specified

SYMBOL	PARAMETER	CONDITIONS	MIN	TYP.	MAX	UNIT
V <sub>CEsat</sub>	Collector-emitter saturation voltage	I <sub>C</sub> =30mA ; I <sub>B</sub> =3mA			1.5	V
V <sub>BE</sub>	Base-emitter on voltage	I <sub>C</sub> =10mA ; V <sub>CE</sub> =10V			1.2	V
V <sub>(BR)CBO</sub>	Collector-base breakdown voltage	I <sub>C</sub> =100 μ A ; I <sub>E</sub> =0	300			V
V <sub>(BR)CEO</sub>	Collector-emitter breakdown voltage	I <sub>C</sub> =1mA ; I <sub>B</sub> =0	300			V
V <sub>(BR)EBO</sub>	Emitter-base breakdown voltage	I <sub>E</sub> =100 μ A ; I <sub>C</sub> =0	6			V
h <sub>FE</sub>	DC current gain	I <sub>C</sub> =10mA ; V <sub>CE</sub> =10V	40		250	
I <sub>CBO</sub>	Collector cut-off current	V <sub>CB</sub> =200V ; I <sub>E</sub> =0			0.1	μ A
I <sub>EBO</sub>	Emitter cut-off current	V <sub>EB</sub> =4V ; I <sub>C</sub> =0			0.1	μ A
C <sub>OB</sub>	Output capacitance	I <sub>E</sub> =0 ; V <sub>CB</sub> =30V ; f=1MHz		3		pF
f <sub>T</sub>	Transition frequency	I <sub>E</sub> =10mA ; V <sub>CB</sub> =30V	50			MHz

Silicon NPN Power Transistors

2SC2371

PACKAGE OUTLINE

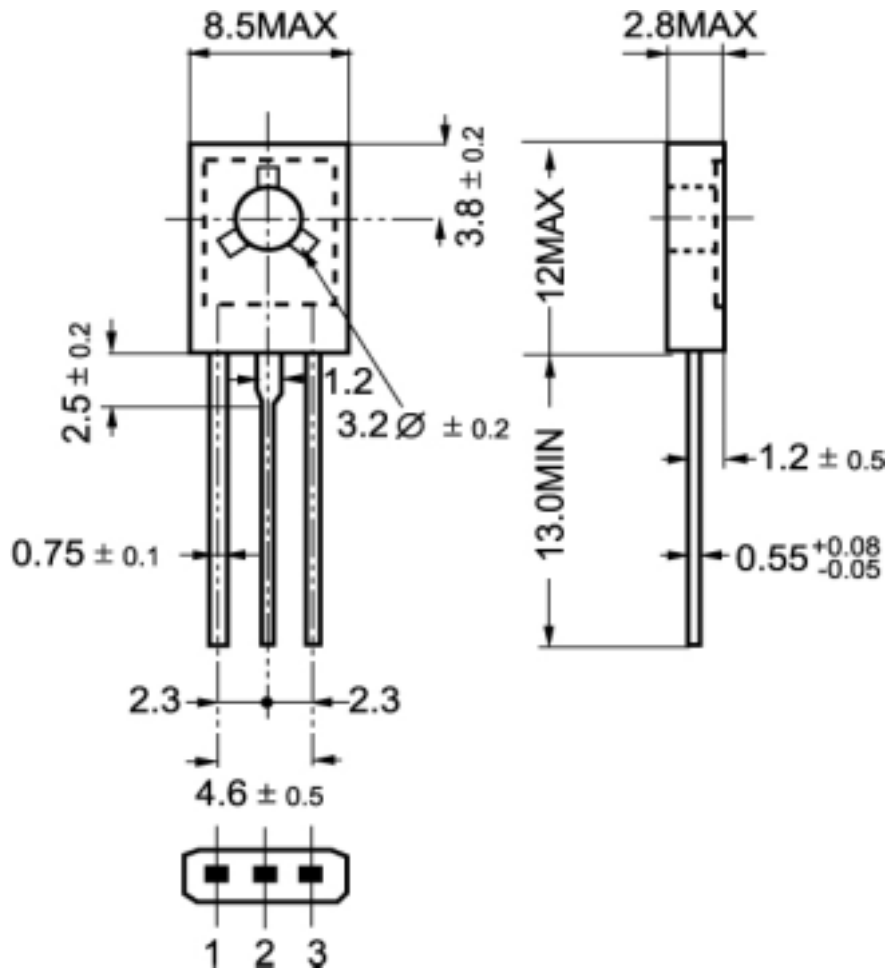

Fig.2 outline dimensions