

Silicon NPN Power Transistors

2SC2371

DESCRIPTION

- With TO-126 package
- High Voltage
- High frequency

APPLICATIONS

- For TV chroma output and vertical output applications

PINNING

PIN	DESCRIPTION
1	Emitter
2	Collector
3	Base

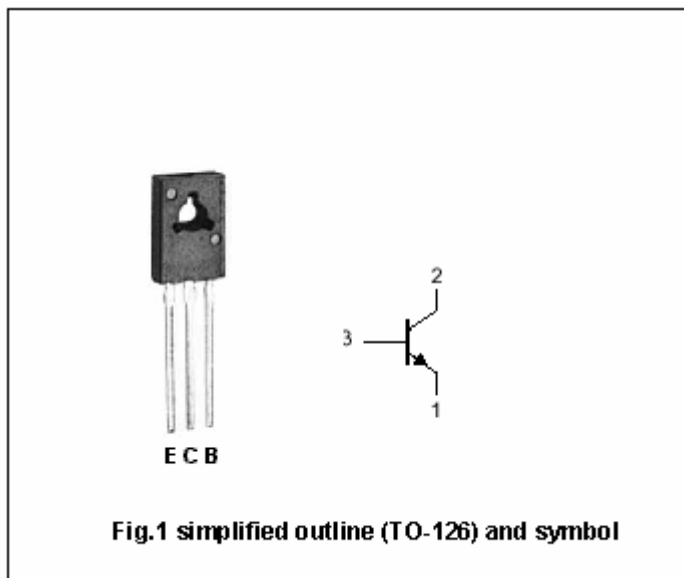

Absolute maximum ratings (Ta=25°C)

SYMBOL	PARAMETER	CONDITIONS	VALUE	UNIT
V _{CBO}	Collector-base voltage	Open emitter	300	V
V _{CEO}	Collector-emitter voltage	Open base	300	V
V _{EBO}	Emitter-base voltage	Open collector	6	V
I _C	Collector current		0.1	A
I _{CM}	Collector current-peak		0.2	A
P _C	Collector power dissipation	T _a =25°C	1.25	W
		T _C =25°C	10	
T _j	Junction temperature		150	°C
T _{stg}	Storage temperature		-40~150	°C

Silicon NPN Power Transistors

2SC2371

CHARACTERISTICS

T_j=25°C unless otherwise specified

SYMBOL	PARAMETER	CONDITIONS	MIN	TYP.	MAX	UNIT
V _{CEsat}	Collector-emitter saturation voltage	I _C =30mA ; I _B =3mA			1.5	V
V _{BE}	Base-emitter on voltage	I _C =10mA ; V _{CE} =10V			1.2	V
V _{(BR)CBO}	Collector-base breakdown voltage	I _C =100μA; I _E =0	300			V
V _{(BR)CEO}	Collector-emitter breakdown voltage	I _C =1mA; I _B =0	300			V
V _{(BR)EBO}	Emitter-base breakdown voltage	I _E =100μA; I _C =0	6			V
h _{FE}	DC current gain	I _C =10mA ; V _{CE} =10V	40		250	
I _{CBO}	Collector cut-off current	V _{CB} =200V; I _E =0			0.1	μA
I _{EBO}	Emitter cut-off current	V _{EB} =4V; I _C =0			0.1	μA
C _{OB}	Output capacitance	I _E =0; V _{CB} =30V; f=1MHz		3		pF
f _T	Transition frequency	I _E =10mA ; V _{CB} =30V	50			MHz

Silicon NPN Power Transistors

2SC2371

PACKAGE OUTLINE

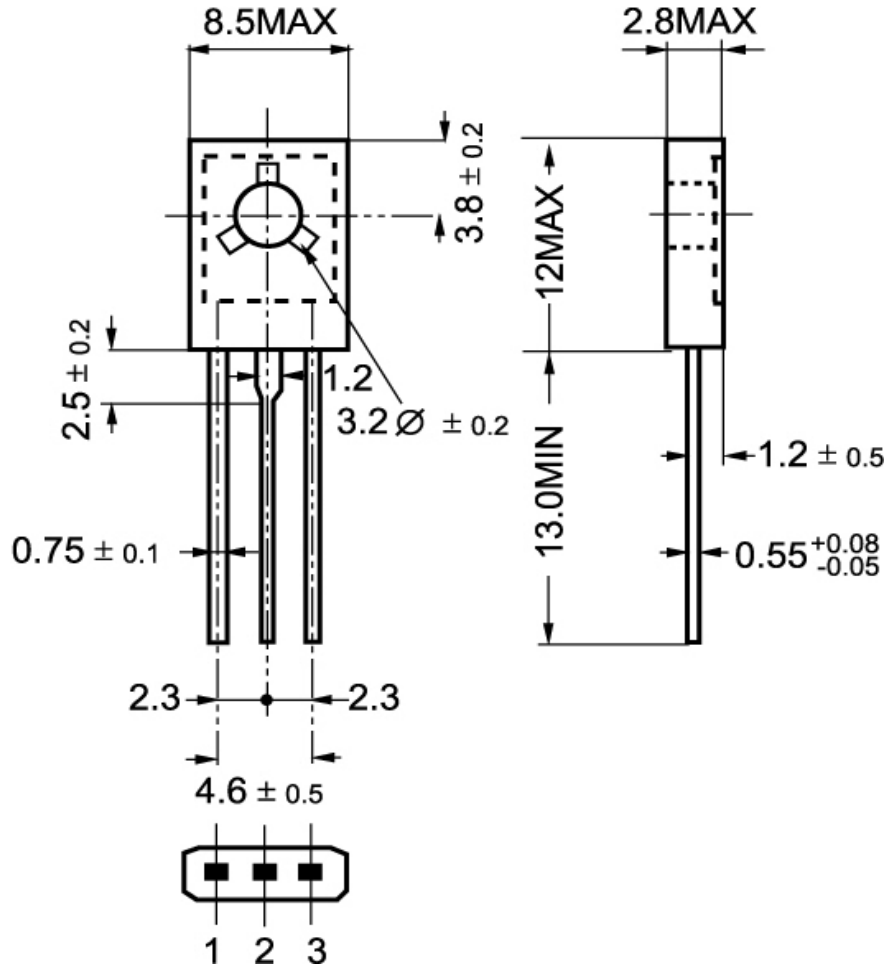

Fig.2 outline dimensions