



EMS101-P1

DC – 6 GHz GaAs MMIC SPDT SWITCH

ISSUED DATE: 10-21-03

FEATURES

- BROADBAND PERFORMANCE
- HIGH ISOLATION
- LOW INSERTION LOSS
- LOW DC POWER CONSUMPTION
- FAST SWITCHING SPEED
- SI3N4 PASSIVATION
- ADVANCED EPITAXIAL HETEROJUNCTION PROFILE PROVIDES HIGH RELIABILITY

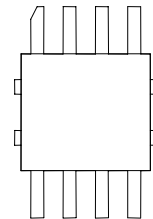

Description

The EMA101-P is a GaAs IC single pole double throw broadband RF switch. It can be used for broadband communications and instrument application. This device is packaged in a SO-8 surface mount package and internally it can be terminated with 50ohm load or short circuit based on requirement .The switch is controlled by the application of 0V/-5V signals to the control lines in accordance with the truth table below.

ELECTRICAL CHARACTERISTICS (T_a = 25 °C)

SYMBOL	PARAMETERS/TEST CONDITIONS		MIN	TYP	MAX	UNIT
F	Operating frequency Range		DC		6	GHz
P1dB	Input Power at 1dB Gain compression	0/-5V Control; 50MHz		20		dBm
		0/-5V Control; 2GHz		26		dBm
Ls	Insertion Loss	(DC-3GHz)		1	1.5	dB
		(3-6GHz)		1.5	2	dB
ISO	Isolation	(DC-3GHz)		30	32	dB
		(3-6GHz)		25	28	dB
VSWR in	Input VSWR			1.8		
VSWR out	Output VSWR			1.8		
T	Switching Speed (50% control to 10%/90%RF)			3	8	nS

Note:

1. VSWR measured in low loss switch state
2. P1dB measured input power at which insertion loss compressed by 1dB
3. All measurement made in a 50Ohm system



EMS101-P1

DC – 6 GHz GaAs MMIC SPDT SWITCH

Package Outline

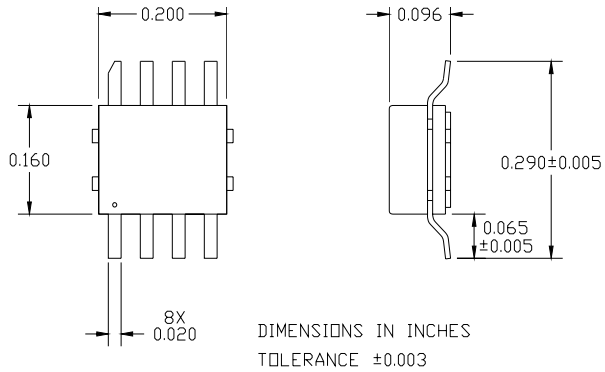

Electrical Schematic

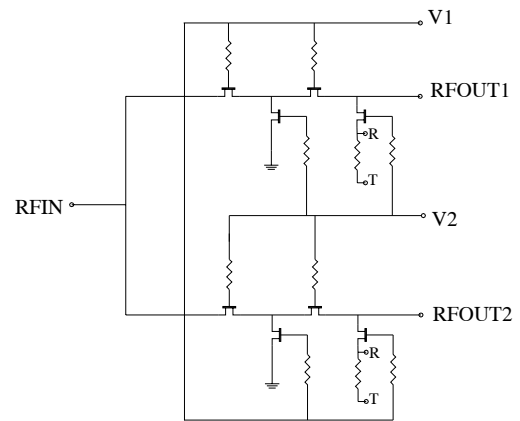

Ground R: Reflective
Ground T: Terminated

Pin Description

Pin	Function
1	Ground
2	RF IN
3	Ground
4	Ground
5	RF OUT1
6	Control V2
7	Control V1
8	RF OUT2

Switch Diagram

V1	V2	RFIN-RFOUT1	RFIN-RFOUT2
0V	-5V	Low Loss	Isolated
-5V	0V	Isolated	Low Loss

Absolute maximum Rating

RF input power	31dBm
Operating temperature	-40°C to +85°C
Storage temperature	-65°C to 150°C