



DTR-1250-SM-GB-H8-HS-CWDM-MR

Multi-rate 5V Very Long Haul CWDM GBIC Transceivers



Features

- ☑ Up to 120km with Single Mode Fiber
- ☑ APD Receiver
- ☑ Eight (8) Wavelength CWDM Transceivers
- ☑ Compliant with GBIC Specification, Rev. 5.5
- ☑ Compatible with IEEE 802.3z 1000BASE-LX Specifications for Gigabit Ethernet
- ☑ Compatible with 1.062GBd Fibre Channel 100-SM-LC-L FC-PI Standards
- ☑ Compatible with Optical Interface Requirements in Annex F of GBIC Specification, Rev. 5.5
- ☑ Compliant with GBIC Serial Module Definition Protocol (Module Definition 4 in Annex D)
- ☑ Hot-pluggable
- ☑ Excellent EMI & ESD Protection
- ☑ Eye Safe (Class I and 1M Laser Safety)
- ☑ Duplex SC Optical Interface

Description

The DTR-1250-SM-GB-H8-HS-CWDM-MR product family of multi-rate GBICs provides a very long haul, single mode solutions for 1000BASE-LX Gigabit Ethernet and 1.062GBd Fibre Channel ports in a networking switch. The transceivers are designed to support data rates ranging from 1250Mb/s down to 125Mb/s and are available in eight (8) wavelengths: 1470nm, 1490nm, 1510nm, 1530nm, 1550nm, 1570nm, 1590nm and 1610nm. The transceivers use a 1550nm DFB laser and an ultra high sensitivity Avalanche Photodiode (APD) receiver to provide a minimum optical link power budget of 33dB which corresponds to a transmission distance of 120km, assuming a total connector/splice/CWDM mux and demux loss of

4.6dB, allocated system penalty of 2dB and fiber loss of 0.22dB/km. All transceivers are Class I Laser products per U.S. FDA/CDRH and Class 1M Laser products per international IEC-60825 standards.

The DTR-1250-SM-GB-H8-HS-CWDM-MR transceivers connect to standard 20-pad GBIC connectors for hot plug capability. This allows the system designer to make configuration changes or maintenance by simply plugging in different types of GBICs without removing the power supply from the host system.

The transceivers operate from a single +5V power supply over an operating case temperature range of -5°C to +70°C.

Absolute Maximum Ratings

Parameter	Symbol	Minimum	Maximum	Units
Storage Temperature	T_{st}	- 40	+ 85	°C
Operating Case Temperature	T_{op}	- 5	+ 70	°C
Supply Voltage	V_{DD}	0	+ 7.0	V
Maximum Input Optical Power (30 seconds max.)	$P_{in, max}$	-	+ 3.0	dBm

DTR-1250-SM-GB-H8-HS-CWDM-MR

Transmitter Performance Characteristics (over Operating Case Temperature, $V_{cc} = 4.75$ to $5.25V$)

Parameter	Symbol	Minimum	Typical	Maximum	Units
Operating Data Rate	B	125	-	1250	Mb/s
Optical Output Power ¹	P_o	+ 0.5	-	+ 5.0	dBm
Center Wavelength	1470	1464	1470	1477.5	nm
	1490	1484	1490	1497.5	
	1510	1504	1510	1517.5	
	1530	1524	1530	1537.5	
	1550	1544	1550	1557.5	
	1570	1564	1570	1577.5	
	1590	1584	1590	1597.5	
	1610	1604	1610	1617.5	
Spectral Width (-20dB)	$\Delta\lambda_{20}$	-	-	1.0	nm
Extinction Ratio	P_{hi}/P_{lo}	9.0^2	-	-	dB
Transmitter Disabled Optical Output Power ¹	P_{dis}	-	-	- 35.0	dBm
Deterministic Jitter	DJ	-	-	80	ps
Total Jitter	TJ	-	-	227	ps
Relative Intensity Noise	RIN	-	-	- 120	dB/Hz
Dispersion Penalty ³	-	-	-	2.0	dB
Transmitter Output Eye	Compliant with IEEE 802.3z & FC-PI Eye Mask				

¹Measured average power coupled into single mode fiber with 2^7-1 PRBS at 1250Mb/s.
²Except for Fast Ethernet (125Mb/s) which is 8.2dB minimum.
³Specified at 2400ps/nm dispersion, which corresponds to the approximate worst-case dispersion for 120km G.652 fiber over the wavelength range of 1464 to 1617.5nm.

Receiver Performance Characteristics (over Operating Case Temperature, $V_{cc} = 4.75$ to $5.25V$)

Parameter	Symbol	Minimum	Typical	Maximum	Units
Operating Data Rate	B	125	-	1250	Mb/s
Minimum Input Optical Power (10 ⁻¹² BER) ¹	1250, 1062 & 125Mb/s	P_{min}	- 32.5	-	dBm
Maximum Input Optical Power (10 ⁻¹² BER)	P_{max}	- 10.0	-	-	dBm
RX_LOS Thresholds	Increasing Light Input	P_{los+}	-	-	dBm
	Decreasing Light Input	P_{los-}	- 45.0	-	
RX_LOS Timing Delay	Increasing Light Input	t_{loss_off}	-	100	μs
	Decreasing Light Input	t_{loss_on}	2.3	100	
RX_LOS Hysteresis	-	0.5	-	-	dB
Deterministic Jitter	DJ	-	-	170	ps
Total Jitter	TJ	-	-	266	ps
Wavelength of Operation	λ	1260	-	1620	nm
Optical Return Loss	ORL	12	-	-	dB
Electrical 3dB Upper Cutoff Frequency	-	-	-	1500	MHz

¹Measured with 2^7-1 PRBS.

Laser Safety: All transceivers are Class I Laser products per FDA/CDRH and Class 1M Laser products per IEC-60825 standards. They must be operated under specified operating conditions.



Optical Communication Products, Inc.

DATE OF MANUFACTURE:

MANUFACTURED IN THE USA
 This product complies with
 21 CFR 1040.10 and 1040.11

Meets Class I Laser Safety Requirements

DTR-1250-SM-GB-H8-HS-CWDM-MR

Transmitter Electrical Interface (over Operating Case Temperature, $V_{CC} = 4.75$ to $5.25V$)

Parameter	Symbol	Minimum	Typical	Maximum	Units
Input Voltage Swing (+TX_DAT & -TX_DAT) ¹	V_{PP-DIF}	0.65	-	2.0	V
Input HIGH Voltage (TX_DISABLE) ²	V_{IH}	2	-	$V_{DD} + 0.3$	V
Input LOW Voltage (TX_DISABLE) ²	V_{IL}	0	-	0.5	V
Output HIGH Voltage (TX_FAULT) ³	V_{OH}	$V_{CC} - 0.5$	-	$V_{CC} + 0.3$	V
Output LOW Voltage (TX_FAULT) ³	V_{OL}	0	-	0.5	V

¹Differential peak-to-peak voltage.

²There is an internal $5.1k\Omega$ pull-up resistor to V_{DDT} .

³Open collector compatible, 4.7 to $10k\Omega$ pull-up resistor to V_{CC} (Host Supply Voltage).

Receiver Electrical Interface (over Operating Case Temperature, $V_{CC} = 4.75$ to $5.25V$)

Parameter	Symbol	Minimum	Typical	Maximum	Units
Output Voltage Swing (+RX_DAT & -RX_DAT) ¹	V_{PP-DIF}	0.60	-	2.0	V
Output HIGH Voltage (RX_LOS) ²	V_{OH}	$V_{CC} - 0.5$	-	$V_{CC} + 0.3$	V
Output LOW Voltage (RX_LOS) ²	V_{OL}	0	-	0.5	V

¹Differential peak-to-peak voltage across external 150Ω load.

²Open collector compatible, 4.7 to $10k\Omega$ pull-up resistor to V_{CC} (Host Supply Voltage).

Electrical Power Supply Characteristics (over Operating Case Temperature, $V_{CC} = 4.75$ to $5.25V$)

Parameter	Symbol	Minimum	Typical	Maximum	Units
Supply Voltage	V_{DD}	4.75	5.0	5.25	V
Supply Current	I_{DD}	-	230	300	mA

Module Definition

Module Definition	MOD_DEF(0) pin 4	MOD_DEF(1) pin 5	MOD_DEF(2) pin 6	Interpretation by Host
4	TTL LOW	SCL	SDA	Serial module definition protocol

Pin Assignments

PIN	FUNCTION	PIN	FUNCTION
1	RX_LOS (RX LOSS OF SIGNAL)	11	RGND (RX GROUND)
2	RGND (RX GROUND)	12	-RX_DAT (RX DATA OUT-)
3	RGND (RX GROUND)	13	+RX_DAT (RX DATA OUT+)
4	MOD_DEF(0)	14	RGND (RX GROUND)
5	MOD_DEF(1)	15	VDDR (RX SUPPLY VOLTAGE)
6	MOD_DEF(2)	16	VDDT (TX SUPPLY VOLTAGE)
7	TX_DISABLE	17	TGND (TX GROUND)
8	TGND (TX GROUND)	18	+TX_DAT (TX DATA IN+)
9	TGND (TX GROUND)	19	-TX_DAT (TX DATA IN-)
10	TX_FAULT	20	TGND (TX GROUND)

DTR-1250-SM-GB-H8-HS-CWDM-MR

Example of host board schematic

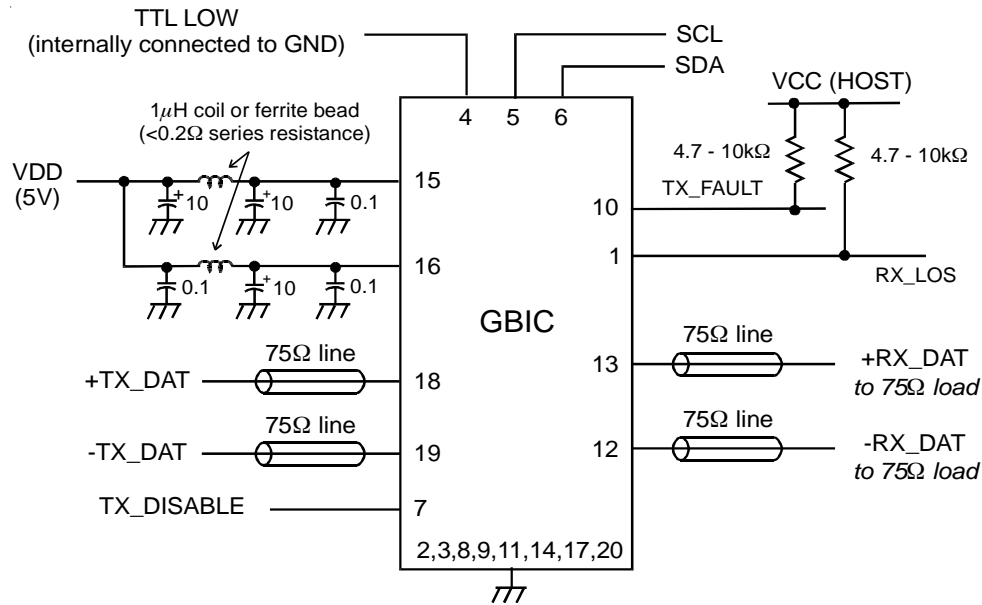

Application Notes

Connection of the GBIC transceiver to the host system: The GBIC's 20-pad connector and two guide tabs connected to the transceiver's circuit ground connect the GBIC to the host system. The two ground tabs make contact to the host circuit ground before the connector pad and discharge any possible component-damaging static electricity. Additionally, surge currents are eliminated by using a special slow start circuit and two-stage contact sequence where operational signals and grounds make contact prior to the power supply (as specified in the GBIC specification, Rev. 5.5).

Electrical interface: All signal interfaces are compliant with the GBIC specification, Rev. 5.5. The high speed DATA interface is differential AC-coupled and can be directly connected to either a 5V or 3.3V SERDES IC. All low speed control and sense input/output signals are open collector TTL compatible and should be pulled up with a 4.7 - 10kΩ resistor on the host board.

RX_LOS: The RX LOSS OF SIGNAL circuit monitors the level of the incoming optical signal and generates a logic HIGH when an insufficient photocurrent is produced.

TX_FAULT: The output indicates LOW when the transmitter is operating normally, and HIGH when the transmitter or laser current is excessive. TX_FAULT is an open collector/drain output and should be pulled up with a 4.7 - 10kΩ resistor on the host board.

TX_DISABLE: When the TX_DISABLE pin is at logic HIGH, the transmitter optical output is disabled (less than -35dBm).

Serial Identification: The DTR-1250-SM-GB-H8-HS-CWDM-MR transceivers are compliant with Annex D (Module Definition 4) of the GBIC specification, Rev. 5.5, which defines the Serial Identification Protocol.

The module definition of GBIC is indicated by the three module definition pins, MOD_DEF(0), MOD_DEF(1) and MOD_DEF(2). Module Definition 4 specifies a serial definition protocol with a two-wire I²C serial interface; upon power up, MOD_DEF(1:2) appear as NC (no connection), and MOD_DEF(0) is TTL LOW. When the host system detects this condition, it activates the serial protocol and generates the serial clock signal (SCL). The negative edge clocks data from the GBIC EEPROM.

The serial data signal (SDA) is for serial data transfer. The host uses SDA in conjunction with SCL to mark the start and end of serial protocol activation.

The data transfer protocol and the details of the mandatory and vendor specific data structures are defined in Annex D of the GBIC specification, Rev. 5.5.

Power supply and grounding: The power supply line should be well-filtered. All 0.1µF power supply bypass capacitors should be as close to the GBIC transceiver module as possible.

DTR-1250-SM-GB-H8-HS-CWDM-MR

Package Outline

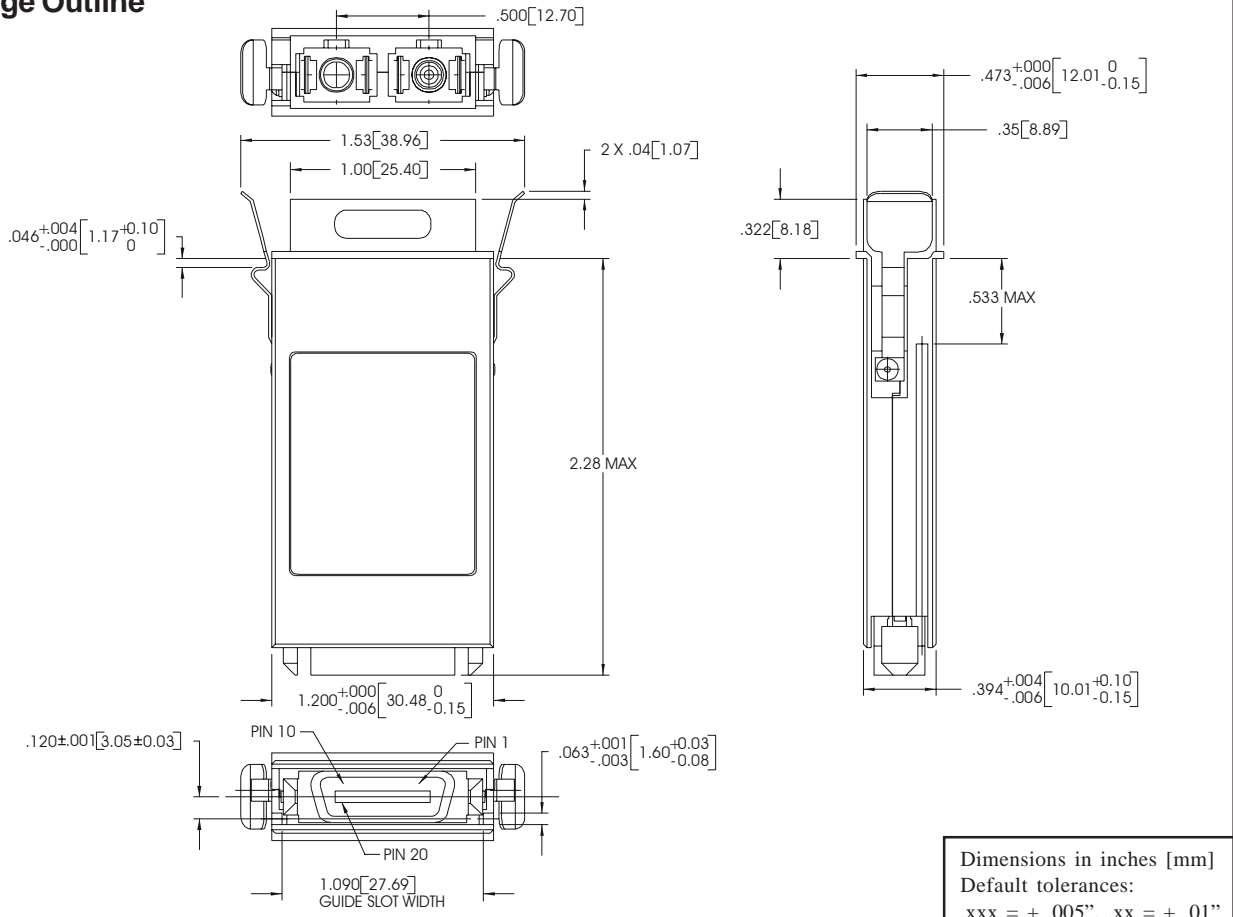

Ordering Information

Model Name	Operating Temperature	Nominal Wavelength	Optical Link Power Budget	Distance ^{1, 2}
DTR-1250-SM-GB-H8-HS-C470-MR	- 5°C to +70°C	1470nm	33dB	120km
DTR-1250-SM-GB-H8-HS-C490-MR	- 5°C to +70°C	1490nm	33dB	120km
DTR-1250-SM-GB-H8-HS-C510-MR	- 5°C to +70°C	1510nm	33dB	120km
DTR-1250-SM-GB-H8-HS-C530-MR	- 5°C to +70°C	1530nm	33dB	120km
DTR-1250-SM-GB-H8-HS-C550-MR	- 5°C to +70°C	1550nm	33dB	120km
DTR-1250-SM-GB-H8-HS-C570-MR	- 5°C to +70°C	1570nm	33dB	120km
DTR-1250-SM-GB-H8-HS-C590-MR	- 5°C to +70°C	1590nm	33dB	120km
DTR-1250-SM-GB-H8-HS-C610-MR	- 5°C to +70°C	1610nm	33dB	120km

¹The indicated transmission distance is for guidelines only, not guaranteed. The exact distance is dependent on the fiber loss, connector/splice/CWDM mux and demux loss and allocated system penalty. Longer distances can be supported if the optical link power budget is satisfied.

²Assuming a total connector/splice/CWDM mux and demux loss of 4.6dB, allocated system penalty of 2dB and fiber loss of 0.22dB/km.

Optical Communication Products, Inc.

6101 Variel Avenue, Woodland Hills, CA 91367, Tel.: 818-251-7100, FAX: 818-251-7111, www.ocp-inc.com

Optical Communication Products, Inc. reserves the right to make changes in equipment design or specifications without notice. Information supplied by Optical Communication Products, Inc. is believed to be accurate and reliable. However, no responsibility is assumed by Optical Communication Products, Inc. for its use nor for any infringements of third parties which may result from its use. No license is granted by implication or otherwise under any patent right of Optical Communication Products, Inc.

© 2006, Optical Communication Products, Inc.