

isc Silicon NPN Power Transistor

BUL128

DESCRIPTION

- Collector–Emitter Sustaining Voltage
: $V_{CEO(SUS)} = 400V(\text{Min.})$
- Low Collector Saturation Voltage
: $V_{CE(sat)} = 0.7V(\text{Max}) @ I_C = 0.5A$
- Very High Switching Speed

APPLICATIONS

- Designed for use in lighting applications and low cost switch-mode power supplies.

ABSOLUTE MAXIMUM RATINGS($T_a=25^\circ\text{C}$)

SYMBOL	PARAMETER	VALUE	UNIT
V_{CES}	Collector-Emitter Voltage	700	V
V_{CEO}	Collector-Emitter Voltage	400	V
V_{EBO}	Emitter-Base Voltage	9	V
I_C	Collector Current-Continuous	4	A
I_{CM}	Collector Current-peak $t_p < 5\text{ms}$	8	A
I_B	Base Current-Continuous	2	A
I_{BM}	Base Current-peak $t_p < 5\text{ms}$	4	A
P_C	Collector Power Dissipation $T_C=25^\circ\text{C}$	70	W
T_j	Junction Temperature	150	$^\circ\text{C}$
T_{stg}	Storage Temperature Range	-65~150	$^\circ\text{C}$

THERMAL CHARACTERISTICS

SYMBOL	PARAMETER	MAX	UNIT
$R_{th\ j-c}$	Thermal Resistance, Junction to Case	1.78	$^\circ\text{C/W}$
$R_{th\ j-a}$	Thermal Resistance, Junction to Ambient	62.5	$^\circ\text{C/W}$

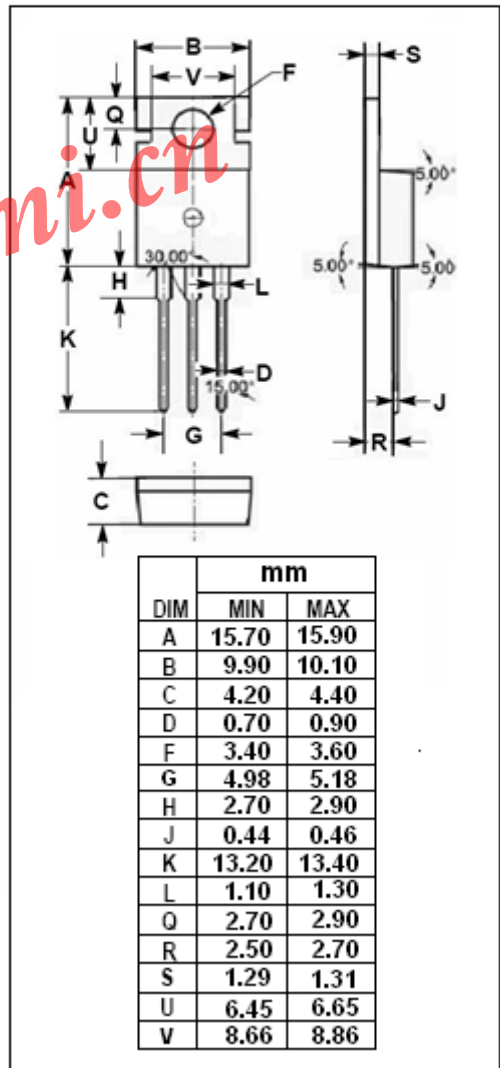
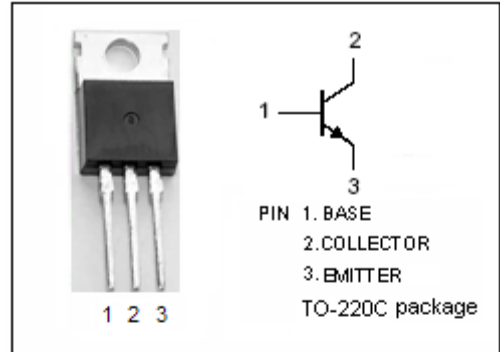

isc Silicon NPN Power Transistor

BUL128

ELECTRICAL CHARACTERISTICS

 $T_C = 25^\circ\text{C}$ unless otherwise specified

SYMBOL	PARAMETER	CONDITIONS	MIN	TYP.	MAX	UNIT
$V_{CEO(SUS)}$	Collector-Emitter Sustaining Voltage	$I_C = 100\text{mA}$; $L = 25\text{mH}$	400			V
$V_{(BR)EBO}$	Emitter-Base Breakdown Voltage	$I_E = 10\text{mA}$; $I_C = 0$	9			V
$V_{CE(sat)-1}$	Collector-Emitter Saturation Voltage	$I_C = 0.5\text{A}$; $I_B = 0.1\text{A}$			0.7	V
$V_{CE(sat)-2}$	Collector-Emitter Saturation Voltage	$I_C = 1\text{A}$; $I_B = 0.2\text{A}$			1.0	V
$V_{CE(sat)-3}$	Collector-Emitter Saturation Voltage	$I_C = 2.5\text{A}$; $I_B = 0.5\text{A}$			1.5	V
$V_{CE(sat)-4}$	Collector-Emitter Saturation Voltage	$I_C = 4\text{A}$; $I_B = 1\text{A}$		0.5		V
$V_{BE(sat)-1}$	Base-Emitter Saturation Voltage	$I_C = 0.5\text{A}$; $I_B = 0.1\text{A}$			1.1	V
$V_{BE(sat)-2}$	Base-Emitter Saturation Voltage	$I_C = 1\text{A}$; $I_B = 0.2\text{A}$			1.2	V
$V_{BE(sat)-3}$	Base-Emitter Saturation Voltage	$I_C = 2.5\text{A}$; $I_B = 0.5\text{A}$			1.3	V
I_{CES}	Collector Cutoff Current	$V_{CE} = 700\text{V}$; $V_{BE} = -1.5\text{V}$ $V_{CE} = 700\text{V}$; $V_{BE} = -1.5\text{V}$, $T_C = 125^\circ\text{C}$			0.1 0.5	mA
I_{CEO}	Collector Cutoff Current	$V_{CE} = 400\text{V}$; $I_B = 0$			0.25	mA
h_{FE-1}	DC Current Gain	$I_C = 10\text{mA}$; $V_{CE} = 5\text{V}$	10			
h_{FE-2}	DC Current Gain	$I_C = 2\text{A}$; $V_{CE} = 5\text{V}$	14		40	

Switching Times, Resistive Load

t_s	Storage Time	$I_C = 2\text{A}$; $V_{CC} = 125\text{V}$; $I_{B1} = -I_{B2} = 0.4\text{A}$; $t_p = 30\ \mu\text{s}$			3.0	μs
t_f	Fall Time				0.4	μs

◆ h_{FE-2} Classifications

A	B
14-28	25-40