

SPECIFICATION FOR APPROVAL

REF :20080804-A

PAGE: 1

PROD. NAME	SHIELDED SMD POWER INDUCTOR	ABC'S DWG NO.	SU4018□□□□L□-□□□
		ABC'S ITEM NO.	

I . CONFIGURATION & DIMENSIONS :

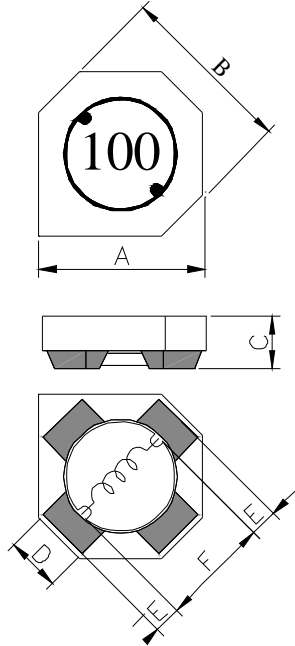

- A : 4.30±0.20 m/m
- B : 4.50±0.20 m/m
- C : 1.80±0.30 m/m
- D : 1.50 typ m/m
- E : 0.50 typ m/m
- F : 3.30 typ m/m
- G : 1.70 ref m/m
- H : 5.30 ref m/m
- I : 1.00 ref m/m
- J : 3.30 ref m/m

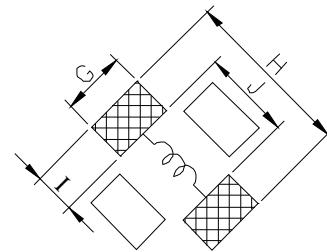

(PCB Pattern suggestion)

II . SCHEMATIC DIAGRAM :

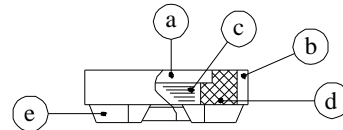

III . MATERIALS :

- a . Core : Ferrite DR core
- b . Core : Ferrite RI core
- c . Wire : Enamelled copper wire (class F & H)
- d . Adhesive : Epoxy resin
- e . Terminal : Ag/Ni/Sn
- f . Remark : Products comply with RoHS' requirements

IV . GENERAL SPECIFICATION :

- a . Temp. rise : 30°C typ.
- b . Rated current :
Base on temp. rise & $\Delta L / L0A=35\%$ typ.
- c . Storage temp. : -40°C ---+125°C
- d . Operating temp. : -40°C ---+105°C
- e . Resistance to solder heat : 260°C .10 secs.

Peak Temp : 260°C max.
Max time above 230°C : 50sec max.
Max time above 200°C : 70sec max.

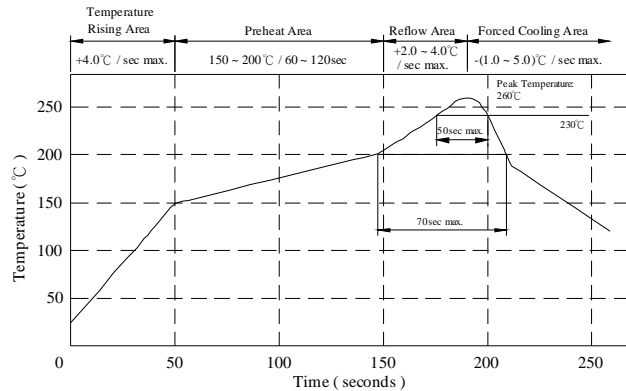

AR-001A

SPECIFICATION FOR APPROVAL

REF : 20080804-A

PAGE: 2

PROD. NAME	SHIELDED SMD POWER INDUCTOR	ABC'S DWG NO.	SU4018□□□□L□-□□□
		ABC'S ITEM NO.	

V . ELECTRICAL CHARACTERISTICS :

DWG No.	Inductance (μ H)	Q ref.	Test Freq. (Hz)		RDC (m Ω)		SRF (MHz)	Irms (mA)	Isat (mA)
			L	Q	typ.	max.	typ.	typ.	typ.
SU40181R2YL□-□□□	1.20 \pm 30%	10	100 K	7.96 M	30	40	120	2700	2200
SU40183R0YL□-□□□	3.00 \pm 30%	10	100 K	7.96 M	45	60	80	2050	1500
SU40184R7YL□-□□□	4.70 \pm 30%	10	100 K	7.96 M	58	78	60	1800	1300
SU40186R8YL□-□□□	6.80 \pm 30%	10	100 K	7.96 M	80	105	45	1500	1050
SU4018100YL□-□□□	10.00 \pm 30%	20	100 K	2.52 M	117	160	30	1200	800
SU4018150YL□-□□□	15.00 \pm 30%	24	100 K	2.52 M	175	240	26	900	600
SU4018220YL□-□□□	22.00 \pm 30%	26	100 K	2.52 M	255	350	20	800	500
SU4018330YL□-□□□	33.00 \pm 30%	22	100 K	2.52 M	310	400	18	650	450
SU4018470YL□-□□□	47.00 \pm 30%	24	100 K	2.52 M	510	660	14	550	400
SU4018680YL□-□□□	68.00 \pm 30%	22	100 K	2.52 M	750	980	10	480	330
SU4018101YL□-□□□	100.0 \pm 30%	60	100 K	796 K	1170	1500	6	320	255

- 1) . □ : Packaging Information... **A** : Bulk **B** : Taping Reel
- 2) . "- □□□" : Reference code
- 3) . Inductance Test Freq. : 100KHz / 0.1V
- 4) . Isat base on $\Delta L / L0A=35\%$ typ.
- 5) . Irms base on Temp. rise 30°C typ.

@ Inductance VS. DC Current Curve

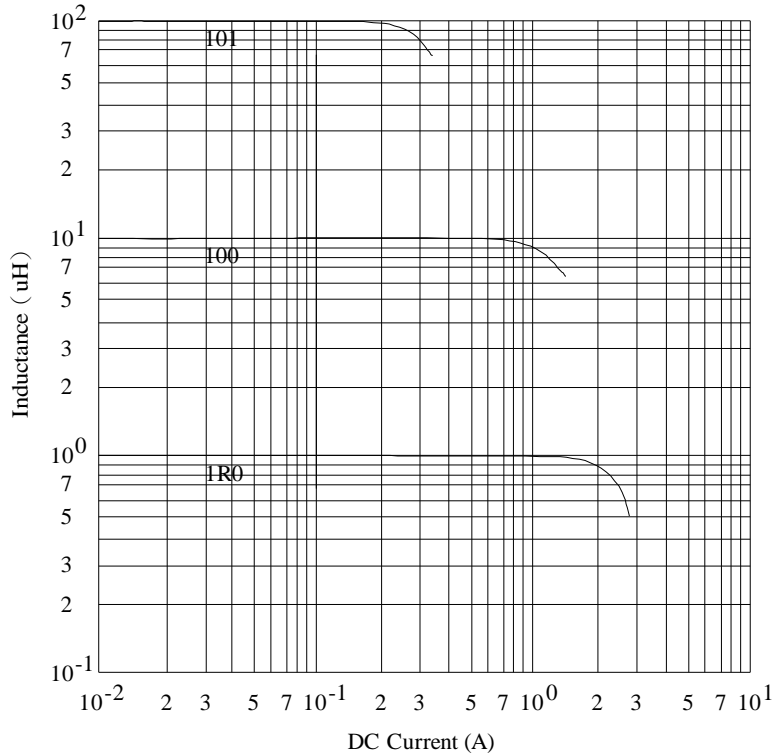

AR-001A



SPECIFICATION FOR APPROVAL

REF: 20080804-A

PAGE: 3

PROD. NAME	SHIELDED SMD POWER INDUCTOR	ABC'S DWG NO.	SU4018□□□□L□-□□□
		ABC'S ITEM NO.	

VI . PACKAGING INFORMATION :

(1) Configuration

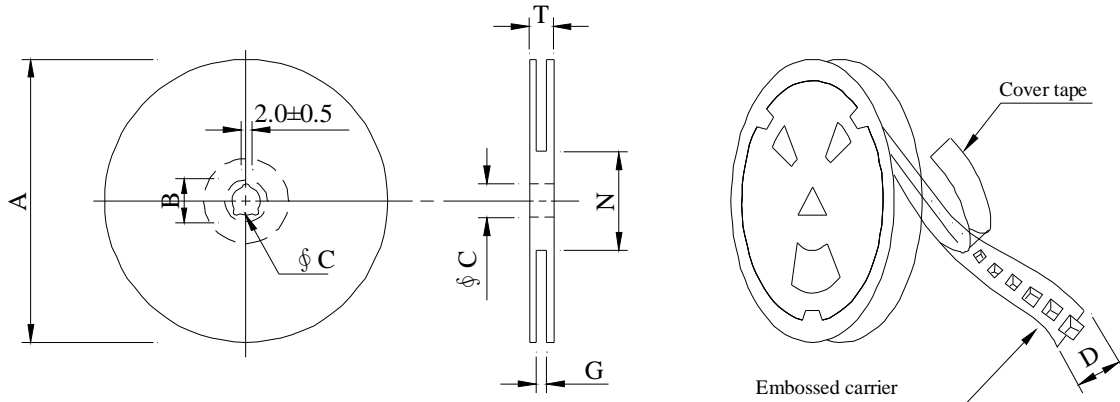

※Carrier tape width : D

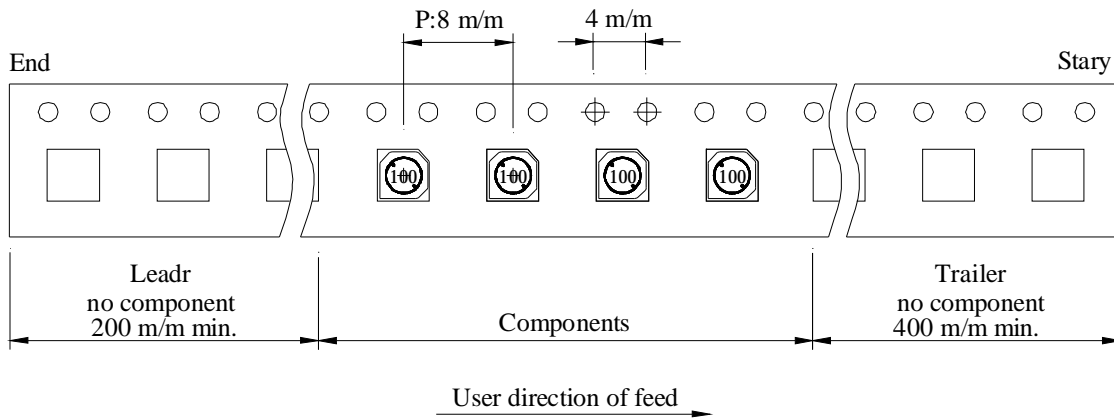

(2) Dimensions

Unit:m/m

Style	A	B	C	D	G	N	T
07 - 12	178	21±0.8	13	12	14 +0	50 -0	16.5

(3) QTY & G.W. Per package

Series	Inner : Reel			Outer : Carton		
	QTY (pcs)	G.W. (gw)	Style	QTY (pcs)	G.W. (Kg)	Size (cm)
SU4018	1,000	180	07 - 12	40,000	8.00	42 x 41 x 24

AR-001A

SPECIFICATION FOR APPROVAL

REF : 20080804-A

PAGE: 5

PROD. NAME	SHIELDED SMD POWER INDUCTOR	ABC'S DWG NO.	SU4018□□□□L□-□□□
		ABC'S ITEM NO.	

VIII . RELIABILITY TEST :

Test item	Specification	Test condition						
Solderability	More than 95% of the terminal electrode shall be covered With fresh solder.	Preheat : 155°C / 4 hours. Solder : Sn96.5 / Ag3 / Cu0.5 or equivalent Solder temp. : 235±5°C Flux : Rosin Dip time : 5±0.5 seconds						
Thermal shock test (Temp. cycle)	Electrical oharacteristics shall not change more than ±20%	<table style="width: 100%; border-collapse: collapse;"> <tr> <td style="text-align: center; border-bottom: 1px solid black;">Room temp. 15 minutes</td> <td style="text-align: center; vertical-align: middle;">→</td> <td style="text-align: center; border-bottom: 1px solid black;">-40 °C 30 minutes</td> </tr> <tr> <td style="text-align: center; border-bottom: 1px solid black;">Room temp. 15 minutes</td> <td style="text-align: center; vertical-align: middle;">→</td> <td style="text-align: center; border-bottom: 1px solid black;">+105 °C 30 minutes</td> </tr> </table> <p>Total : 50 cycles</p>	Room temp. 15 minutes	→	-40 °C 30 minutes	Room temp. 15 minutes	→	+105 °C 30 minutes
Room temp. 15 minutes	→	-40 °C 30 minutes						
Room temp. 15 minutes	→	+105 °C 30 minutes						
Humidity test		Temperature : 40±2°C Humidity : 90±5% Time : 1000 hours						
High temp. Resistance test		Temperature : 105±5°C Applied current : Per spec. Time : 96 hours						

AR-001A

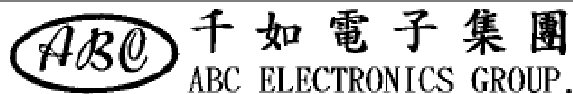

SPECIFICATION FOR APPROVAL

REF : 20080804-A

PAGE: 6

PROD. NAME	SHIELDED SMD POWER INDUCTOR	ABC'S DWG NO.	SU4018□□□□L□-□□□
		ABC'S ITEM NO.	

IX . UL CARD :

OBMW2 September 8, 2000

Magnet Wire-Component

JUNG SHING WIRE CO LTD E174837

231 CHUNG CHENG RD, SEC 3 JEN-TEH HSIANG, TAINAN
HSIEN TAIWAN

Mtl Dsg	Mark Dsg	BC	Coat Typ	OC	ANSI Type	Temp Class
AIW	---	Polyamideimide		---	MW81-C	220
CFUEWB	---	Polyurethane		---	MW75C	130
EIAIW	---	Polyesterimide		Polyamideimide	MW35C	200
EILOCKY	---	Polyesterimide		Polyamide	---	180
EILOCKW	---	Polyesterimide		Modified Epoxy	---	200
EIW	---	Polyesterimide		---	---	220
EIW-2	---	Polyesterimide		---	MW74-C	200
FL.EILOCKY	---	Modified Polyester		Polyamide	---	155
LSFFW	---	Polyurethane		---	MW79-C	155
LSUEW	---	Polyurethane		---	---	130
PEW	---	Polyester		---	---	155
PEY	---	Polyester		Nylon	MW24-C	155
SF.FLW	---	Modified Polyester		---	MW26C	155
SF.EIW	---	Polyesterimide		---	MW77C	180
SF.BY@	---	Modified Polyester		Nylon	MW27-C	155
SF.FLY@	---	Modified Polyester		Nylon	MW27-C	155
SF.BLOCKBS	---	Modified Polyester		Modified Polyamide	---	155
SF.EILOCKY#	---	Polyesterimide		Polyamide	---	180
SF.EILOCKBS	---	Polyesterimide		Modified Polyamide	---	180
SF.BW@	---	Modified Polyester		---	MW26C	155
SFFW	---	Polyurethane		---	MW79	155

287806002 Page 1 of 2

A not-for-profit organization dedicated to public safety and committed to quality service

Mtl Dsg	Mark Dsg	BC	Coat Typ	OC	ANSI Type	Temp Class
SFFY	---	Polyurethane		Polyamide	MW80C	155
UEW-1	---	Polyurethane		---	MW2-C	105
UEW-2	---	Polyurethane		---	---	130
UEW-4	---	Polyurethane		---	MW75C	130
UEY	---	Polyurethane		Nylon	MW28-C	130
UEY-2	---	Polyurethane		Polyamide	MW28-C	130

@ - May be suffixed by LZ; # - May be suffixed by LZ, EL or LZI.
LZ - Signifies magened wires twisted together; EL - signifies base coated magnet wire laid parallel with top coat applied overall; LZL - signifies base coated magnet wire twisted together and covered with top coat overall.

Marking: Company name or trademarks **JSW** or 榮星電線 , material designation or marked designation on packaed or reel, and Recognized Component Mark.

See General Information Preceding These Recognitions
For use only in equipment where the acceptability of the combination is determined by Underwriters Laboratories Inc.

287806002 Page 2 of 2

OBMW2E174837
September 8, 2000

AR-001A



SPECIFICATION FOR APPROVAL

REF :20080804-A

PAGE: 7

PROD. NAME	SHIELDED SMD POWER INDUCTOR	ABC'S DWG NO. ABC'S ITEM NO.	SU4018□□□□L□-□□□
---------------	--------------------------------	---------------------------------	------------------

OBMW2 August 27, 1999
 Magnet Wire-Component

ELEKTRISOLA (MALAYSIA) SDN BHD E143312
 IALAN DAMN SATU IANDA BAIK 28750 BENTONG, PAHANG
 DARUL MAKMUR MALAYSIA

Mtl Dsg	Mark Dsg	Coating Type		ANSI Typ	Temp Class
		BC	OC		
Estersol 160	E180	Polyesterimide (solderable)	—	MW-77	180
Amldester 200	A200	Polyesterimide	—	MW-74	200
Polysol-N 155	PN155	Polyurethane	Nylon	MW-80, MW-28	155, 100
Polysol 155	P155	Polyurethane	—	MW-79, MW-79	155, 130
Polysol 155g	Pg155	Polyurethane	—	MW-79	130
Polysol 155p	Pp155,Gp155	Polyurethane	—	MW-79	155
Polysol 160	P160	Polyurethane	—	MW-79	155
Polysol 180	P180	Polyurethane	—	MW-79	155
Polysol 170	P170 or G170	Polyurethane	—	MW-79	156
Polysol-N 180	PN180	Polyurethane	Nylon	—	180

Marking : Company name/material designation or marked designation and factory identification on package ok reel

See General Information preceding These Recognitions
 For use only in equipment where the acceptability of the combination is determined by Underwriters Laboratories Inc.

AR-001A

