

Speaker / Headphone Amplifier Series

1.1W to 1.5W



Monaural Speaker Amplifiers

BD7830NUV

●Description

The BD7830NUV is a monaural speaker amplifier that operates at low voltage and was developed for portable navigation and mobile audio products.

When in standby mode, its current consumption is 0 μ A, and since it switches quickly and quietly from standby to ON, it is especially well suited for applications where there is frequent switching between standby and ON.

●Features

- 1) BTL monaural audio power amplifier
- 2) High power 2.25W 4 Ω at Vcc=5V ,THD+N=10%
High power 1.55W 8 Ω at Vcc=5V ,THD+N=10%
High power 0.77W 8 Ω at Vcc=3.6V ,THD+N=10%
- 3) Wide operating supply voltage range: 2.4~5.5V
- 4) Low standby current: 0 μ A
- 5) Fast turn on/off time:46msec
- 6) Built-in Fade-in/out function
- 7) Built-in anti-pop function
- 8) Built-in thermal shutdown function
- 9) Very small package(VSON008V2030)

●Applications

Mobile phones, Mobile electronic applications

● Absolute Maximum Ratings (Ta=+25°C)

Parameter	Symbol	Ratings	Unit
Supply voltage	Vcc	6.0	V
Power dissipation	Pd	530 *1	mW
Storage temperature range	Tstg	-55~+150	°C
STBY input range	Vstby	-0.1~Vcc+0.1	V

*1 ROHM standard one layer board (70mm × 70mm × 1.6mm) mounted, deratings is done at 4.24mW/°C above Ta=+25°C.

● Operating Range

Parameter	Symbol	Range	Unit
Temperature range	Topr	-40~+85	°C
Supply voltage	Vcc	+2.4~+5.5	V

※ This product is not designed for protection against radioactive rays.

● Application Circuit Example

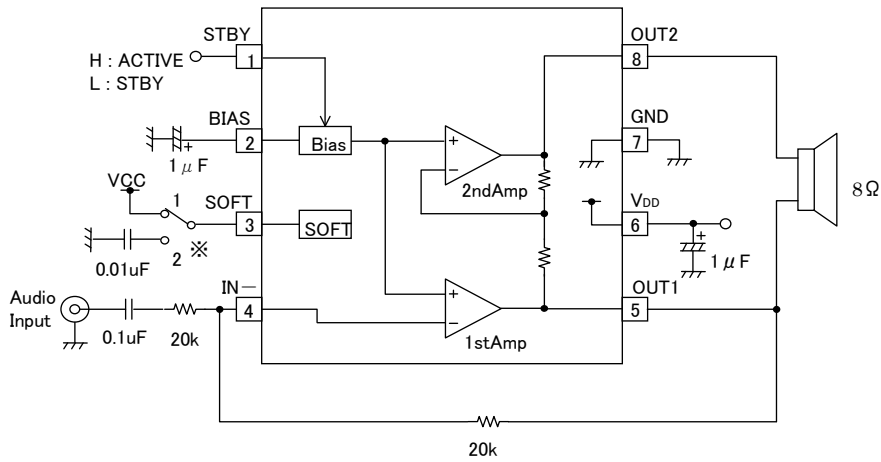

※3pin SOFT terminal

- 1 : Usually
- 2 : Enable to adjust fade in/out time by external capacitor

● Outer dimension

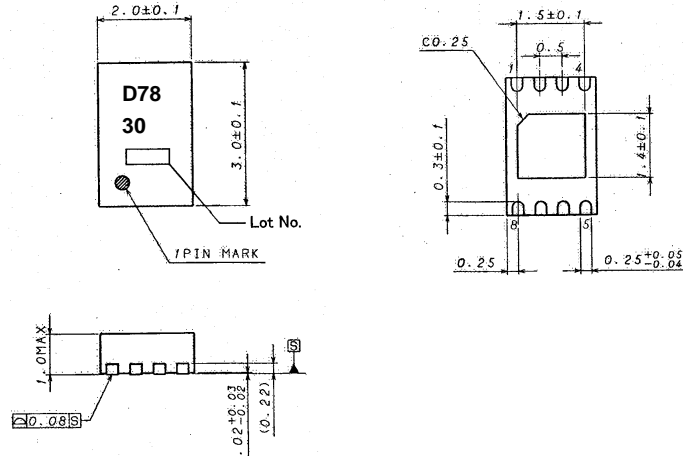

● Reference land pattern (adapt as necessary to suit conditions during actual design.)

Unit: mm

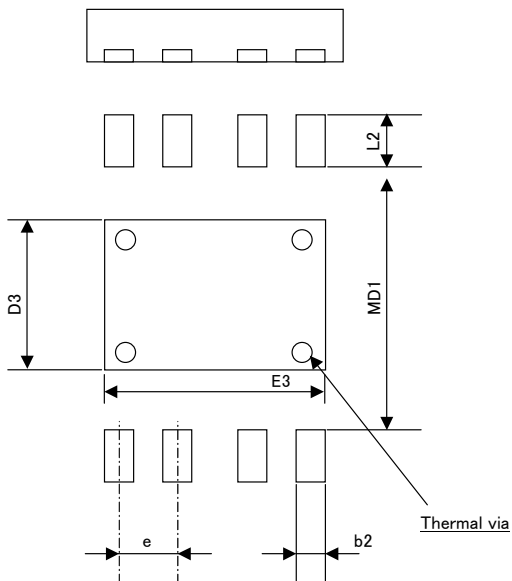

PKG type	Lead pitch e	Land		
		Gap MD1	Length L2	Width b2
VSON008V2030	0.50	2.20	0.70	0.27

PKG type	Central pad		Thermal via	
	Length D3	Width E3	Pitch	Diameter
VSON008V2030	1.20	1.60	—	φ 0.300

※ This package is a non-lead type, so solderability of the lead ends and sides is not guaranteed.

● Electrical characteristics (Unless otherwise noted, Ta=+25°C, Vcc=+3.0V, f=1kHz, RL=8Ω)

Parameter	Symbol	Limit			Unit	Monitor pin	Condition
		MIN.	TYP.	MAX.			
Supply current	I _{CC}	—	3.2	6.8	mA	6	Active mode
Standby supply current	I _{STBY}	—	0	2	uA	6	Standby mode
Output power	P _O	280	420	—	mW	5&8	BTL, THD+N=1% *1
Total harmonic distortion	T _{HD+N}	—	0.1	0.5	%	5&8	BTL, Po=150mW *1
Voltage gain1	A _{V1}	-1	0	+1	dB	5	Vin=-20dBV, 1stAmp
Voltage gain2	A _{V2}	-1	0	+1	dB	8	Vin=-20dBV, 2ndAmp
Power supply rejection ratio	P _{SRR}	40	57	—	dB	5&8	BTL, Vripple=0.2Vpp, *2
Mute attenuation	M _{UTE}	60	80	—	dB	5&8	BTL, Vin=-20dBV
Output voltage	V _O	1.35	1.5	1.65	V	5&8	Vin=0V
Output offset voltage	ΔV _O	-40	0	+40	mV	5&8	ΔV _O = Vo1-Vo2
STBY release voltage	V _{STBYH}	1.4	—	Vcc+0.1	V	1	Active mode
STBY hold voltage	V _{STBYL}	-0.1	—	0.4	V	1	Standby mode
STBY input current H	I _{STBYH}	20	30	40	uA	1	V _{STBY} =3V
STBY input current L	I _{STBYL}	-2	0	—	uA	1	V _{STBY} =0V

*1: B.W.=400~30kHz, *2: DIN AUDIO, SE: Single End, BTL: The voltage between 5pin and 8pin

● Measurement Circuit Diagram

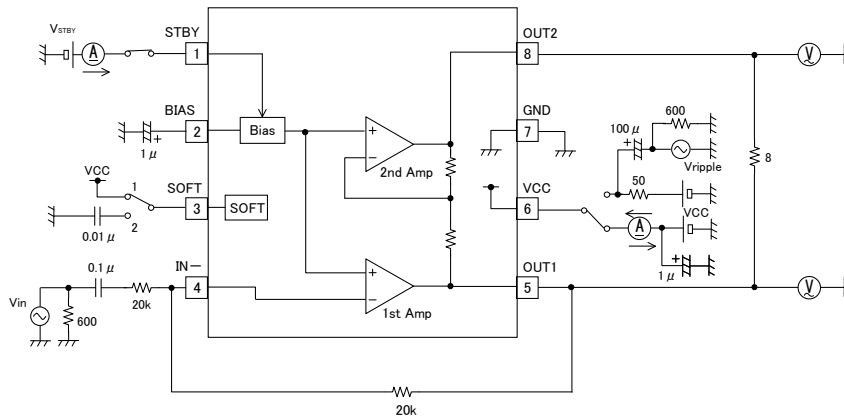

※3pin SOFT terminal

- 1 : Usually
- 2 : Enable to adjust fade in/out time by external capacitor

● Block diagram

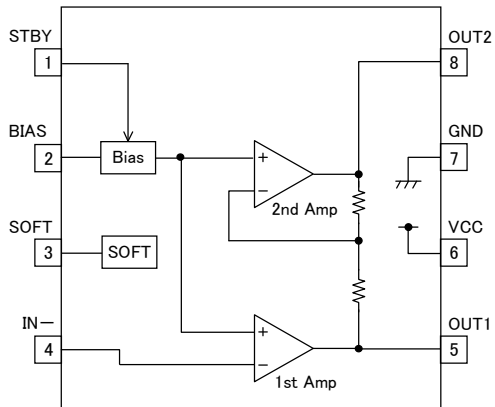

● Pin assignment

PIN No.	PIN Name
1	STBY
2	BIAS
3	SOFT
4	IN-
5	OUT1
6	VCC
7	GND
8	OUT2

● Input/output equivalent circuit

PIN No.	PIN Name	PIN description	Equivalent circuit
1	STBY	Active/Standby Control pin STBY=H → Active STBY=L → Standby	
2	BIAS	Bias capacitor Connection pin	
3	SOFT	Fade-in/out Adjustment pin	
4	IN-	Input pin	
5 8	OUT1 OUT2	Output pin	
6	VCC	Power supply pin	
7	GND	GND pin	

注) The above numerical values are typical values for the design, which are not guaranteed.

● Description of operations

① ON/OFF operation by STBY pin

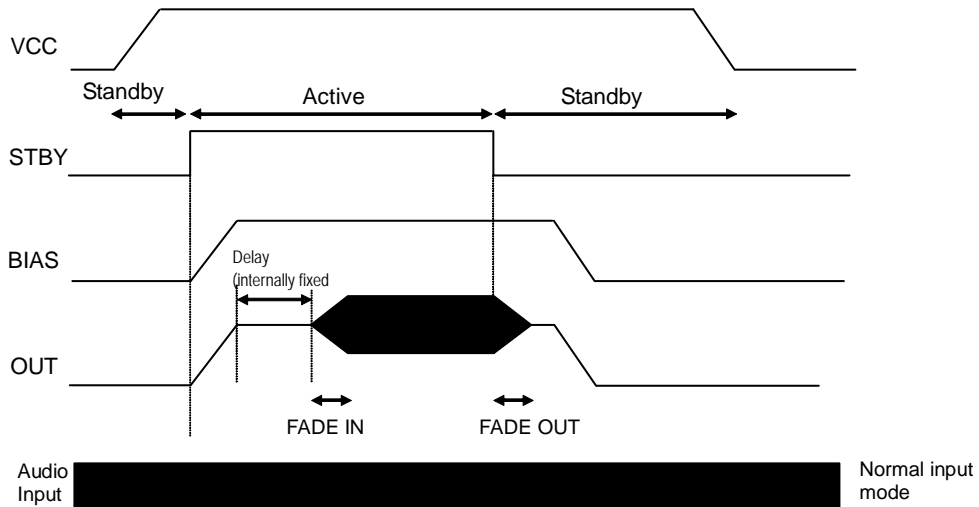

Once VCC = H, when STBY = L → H then BIAS and output (OUT) are activated.

Once BIAS has become stable (= 1/2 VCC), output (OUT) fades in (FADE IN).

Once STBY = H → L, output (OUT) starts to fade out (FADE OUT), and when fade-out ends, the BIAS falls.

② ON/OFF control by shorting of VCC and STBY pins

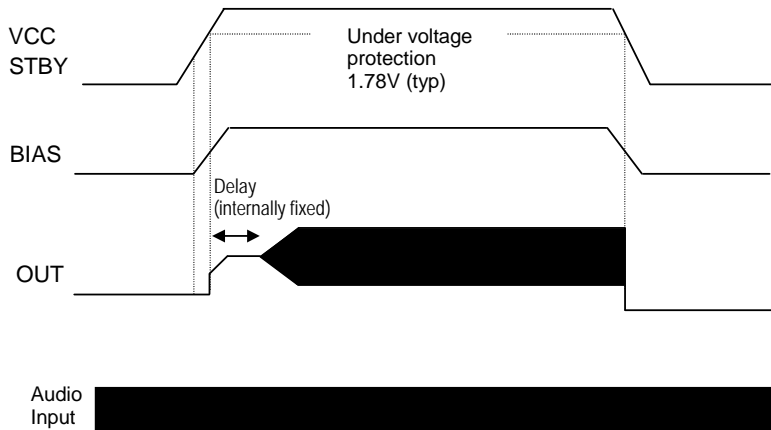

When VCC = STBY = L → H, BIAS is activated.

During low power mode (VCC < 1.78 V) protection is used to keep output (OUT) at low level, and FADE IN occurs when this protection is canceled.

When VCC = STBY = H → L, output (OUT) falls without FADE OUT.

● External components and cautions points

Setting of external components

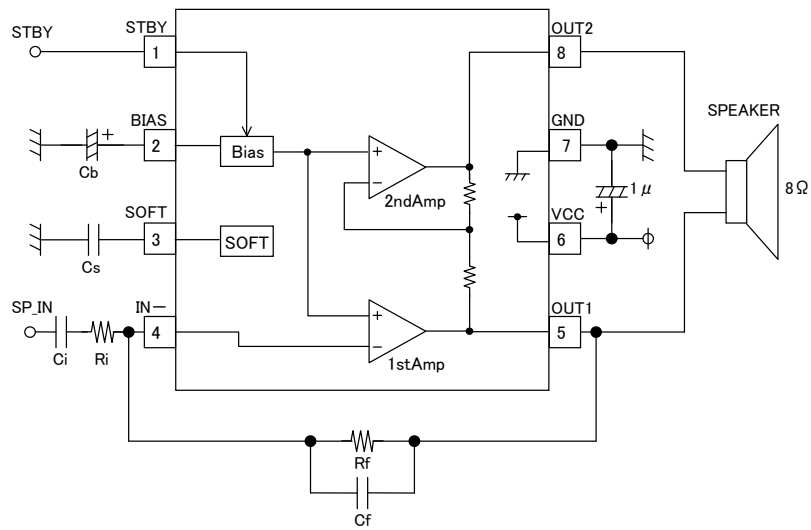

● Cb

This is a bypass capacitor, which is used for bias voltage stabilization. When a larger capacitor is used, the efficiency of voltage ripple rejection can be improved. When tuning, note with caution that Cb can affect the activation time.

Cb – Power Supply Ripple Rejection Ratio

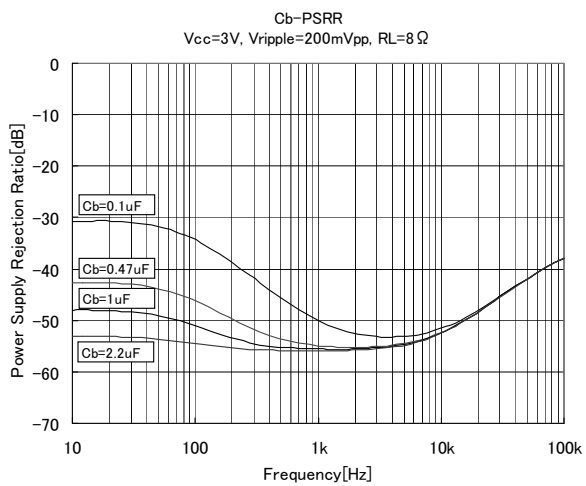

Cb – Turn-on Time

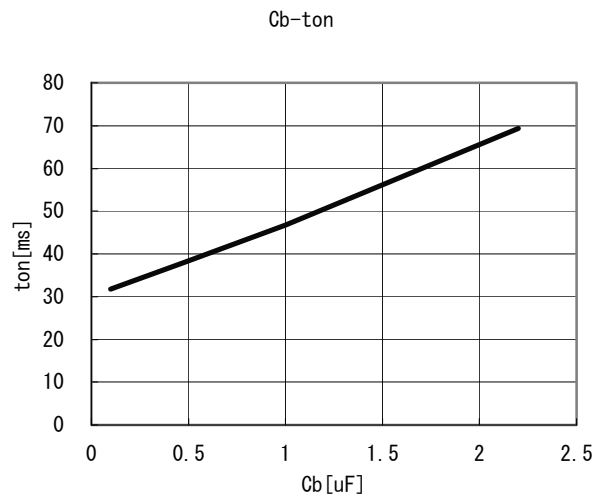

● Cs

This capacitor is for adjustment of the FADE IN/OUT times.

The FADE IN/OUT functions soften the operation (IN and OUT) of BTL output when switching between standby and active modes.

When a capacitor is connected to the SOFT pin (pin 3), the FADE IN/OUT functions are valid.

When the capacitor rating is increased, the FADE IN/OUT effect is also increased, but note with caution when setting this that it also affects the activation time.

If the FADE IN/OUT functions are not being used, connect the SOFT pin (pin 3) to VCC.

• Fade-in/out waveforms

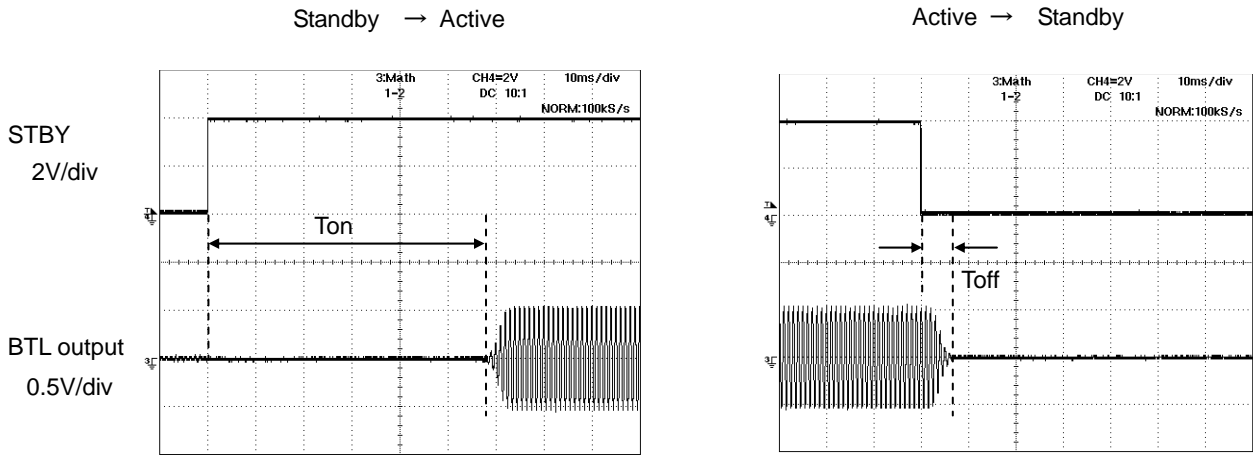

Cs - Fade-in/out Time

Cs-ton, toff

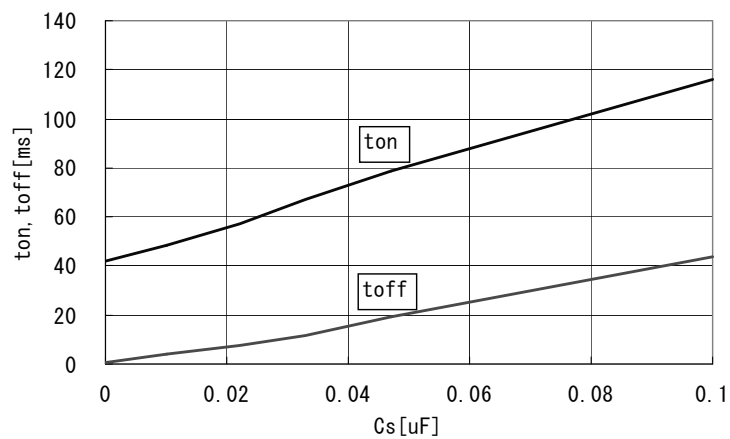

- Ci

This is a DC cut-off input coupling capacitor for the amp input pin.
This includes an Ri and a high-pass filter. The cut-off frequency is calculated as follows.

$$f_{cL} = \frac{1}{2\pi \times R_i \times C_i} \quad [\text{Hz}]$$

Ci – Low Frequency Characteristics

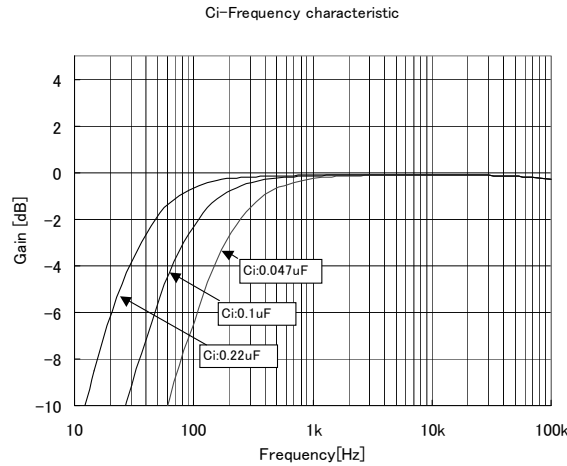

Capacitors of a certain size are required for coupling without attenuation of low frequencies, but in most cases of speakers used in portable equipment, it is nearly impossible to reproduce signals in the 100 to 200 Hz range or below.

Even when a larger capacitor is used instead, it may not improve system performance.

Also, pop sounds can affect the capacitance (Ci) of the capacitor.

A larger coupling capacitor requires a greater charge to reach the bias DC voltage (normally 1/2 VCC).

Because this charge current is supplied from the output due to routing of feedback, pop sounds occur easily at startup.

Consequently, pop sounds can be minimized by selecting the smallest capacitor that still has the required low-frequency response.

- Ri

This is inverting input resistance, which sets the closed loop gain in conjunction with Rf.

- Rf

This is feedback resistance, which sets closed loop gain in conjunction with Rf. The amp gain is set using the following formula.

$$\text{Gain} = 20 \log \left(\frac{R_f}{R_i} \right) \quad [\text{dB}]$$

- Cf

This is a feedback capacitor, which is used to cut high frequencies.

This includes Rf and a low-pass filter. The cut-off frequency is calculated as follows.

$$f_{cL} = \frac{1}{2\pi \times R_i \times C_i} \quad [\text{Hz}]$$

● Selection of external components

① Setting gain from desired output

Output P_o is determined via the following formula, from which the required gain A_v can also be obtained.

$$P_o [W] = V_o^2 [V_{rms}] / R_L [\Omega]$$

$$V_o = A_v \cdot V_{in}$$

$$A_v \geq \sqrt{P_o \cdot R_L} / V_{in}$$

② Setting input resistance and feedback resistance from gain

Gain A_v is determined via the following formula, from which input resistance R_{in} and feedback resistance R_f can be set.

$$A_v = (R_f / R_{in}) \cdot 2$$

R_{in} is set with the input side's drive capacity taken into account.

③ Setting input coupling capacitor from low-range cut-off frequency

Low-range cut-off frequency f_c is determined via the following formula, from which input coupling capacitor C_{in} can be set.

$$f_c [Hz] = 1 / (2\pi \cdot R_{in} \cdot C_{in})$$

$$C_{in} \geq 1 / (2\pi \cdot R_{in} \cdot f_c)$$

④ Setting bias capacitor and SOFT capacitor to minimize pops

It is recommended that the capacitance of the bias capacitor C_B be set to at least 10 times that of the input coupling capacitor C_{in} , in order to soften the rise of the bias voltage while improving the C_{in} following ability.

Also, when a higher gain is used, the capacitance of the SOFT capacitor C_s can be raised to control pop sounds.

$$A_v = 2 \text{ (6 dB at BTL)} \rightarrow C_s \cdot (80 / f_c) \geq 0.01 \mu F$$

$$A_v = 4 \text{ (12 dB at BTL)} \rightarrow C_s \cdot (80 / f_c) \geq 0.022 \mu F$$

$$A_v = 8 \text{ (18 dB at BTL)} \rightarrow C_s \cdot (80 / f_c) \geq 0.033 \mu F$$

$$A_v = 20 \text{ (26 dB at BTL)} \rightarrow C_s \cdot (80 / f_c) \geq 0.068 \mu F$$

● Use when $VCC = STBY$ short

Since this IC is designed on the assumption that it will be used to switch standby mode ON and OFF while the power supply remains ON, normally STBY should be switched from H to L and the SOFT voltage should be discharged before powering down.

When used while $VCC = STBY$ short, pop sounds may occur if the IC's power supply is reduced prior to discharging the SOFT voltage.

To prevent pop sounds, you must ① set STBY = H→L before setting VCC = H→L, and ② forcibly discharge the SOFT voltage.

A sample circuit in which $VCC = STBY$ short is used is shown below.

• Sample circuit configuration when $VCC = STBY$ short

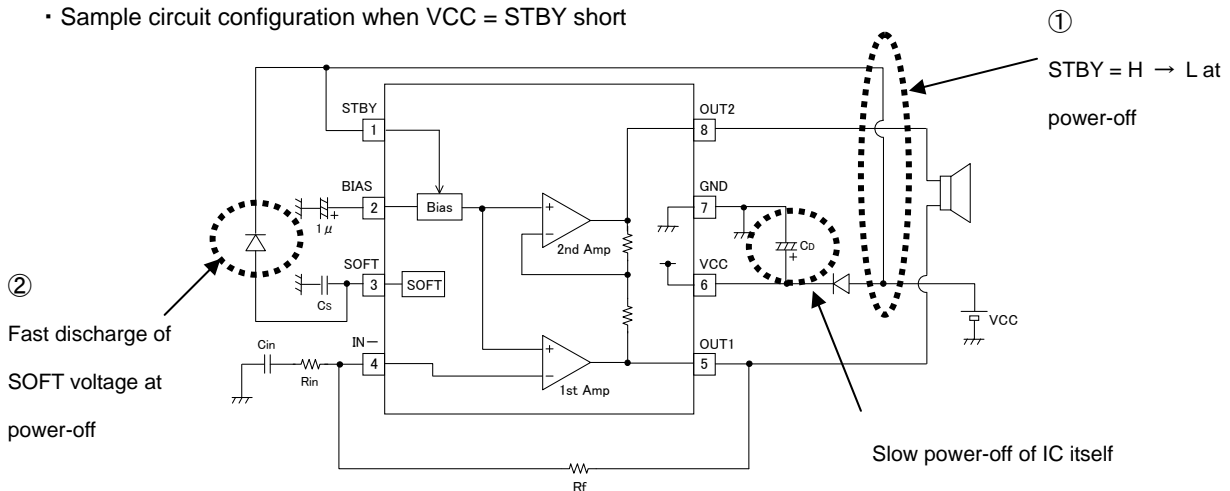

● Mechanism of pop sounds

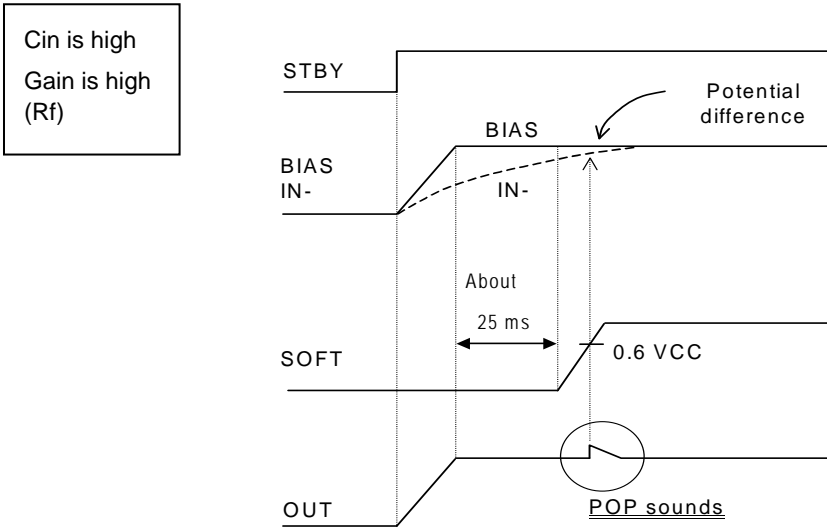
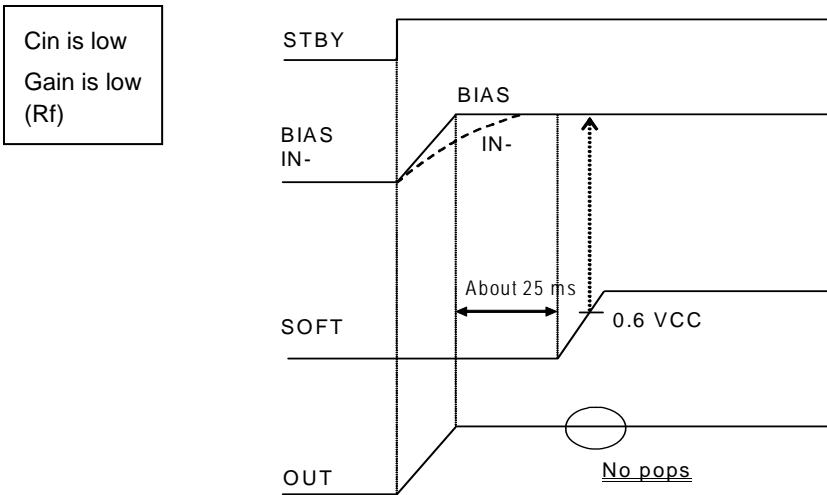

When SOFT voltage reaches 0.6 VCC, if there is a potential difference between BIAS and IN-, pop sounds will occur.

At startup, the input coupling C_{in} is charged from output OUT via the feedback resistance R_f , so when C_{in} and R_f are high, charging takes longer and pop sounds can easily occur.

The rise of the SOFT voltage is changed by C_s , so pop sounds can be reduced by setting C_s high.

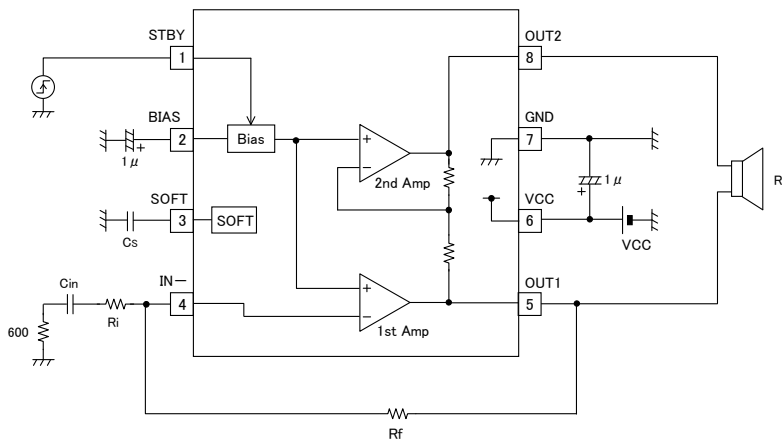

● Bass boost function

External components can be added to this chip to provide a bass boost function.

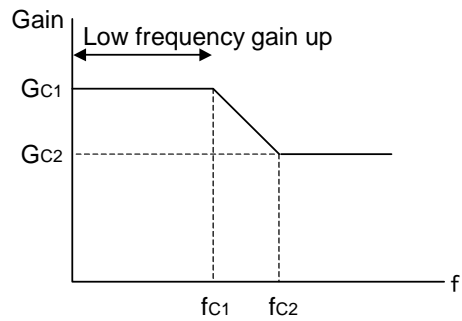
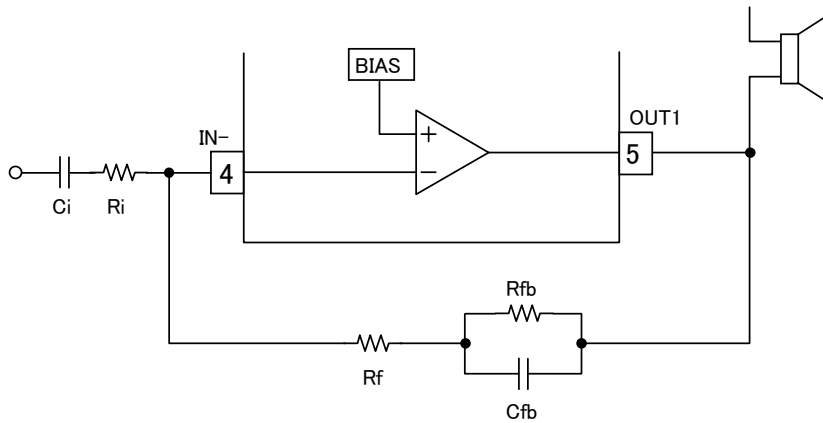

$$f_{C2} = \frac{1}{2\pi * C_{fb} * R_f} \quad [\text{Hz}]$$

$$f_{C1} = \frac{1}{2\pi * C_{fb} * (R_f // R_{fb})} \quad [\text{Hz}]$$

$$G_{C1} = 20 \log \frac{R_f + R_{fb}}{R_i} \quad [\text{dB}]$$

$$G_{C2} = 20 \log \frac{R_f}{R_i} \quad (\text{normal use}) \quad [\text{dB}]$$

● Thermal shutdown function

When the chip exceeds the T_{jmax} (150°C) temperature by reaching a temperature of 180°C or above, the protection function is activated.

High impedance is for OUT1 and OUT2 during protected mode.

Protection is canceled and normal operation is resumed when the chip's temperature falls to 120°C or below.

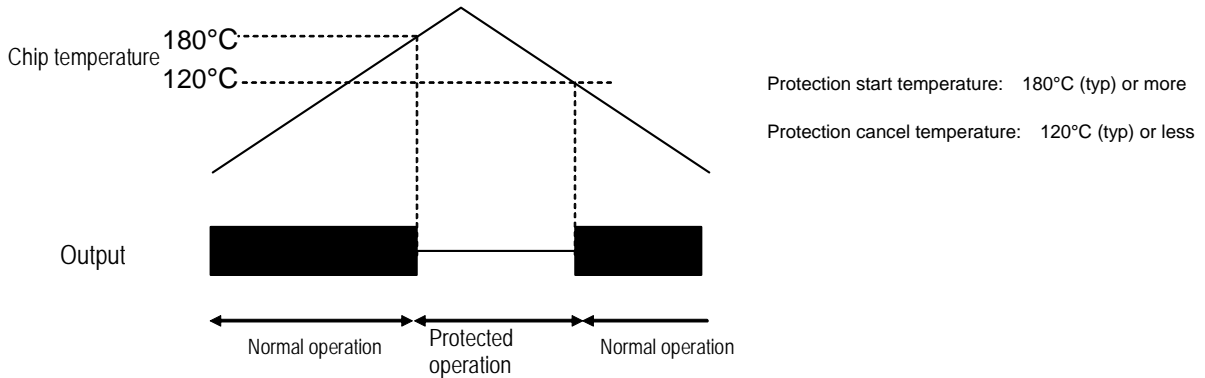

● Thermal design of chip

The characteristics of the IC vary greatly depending on the use temperature, and when the maximum allowable junction temperature is exceeded, components may deteriorate or become damaged. Thermal considerations are needed for this chip from two standpoints: preventing instantaneous damage and improving long-term reliability. Note the following points with caution.

The absolute maximum ratings for each chip include the maximum junction temperature (T_{jMAX}) and operating temperature rate (T_{opr}), and these values should be referred to when using the Pd-Ta characteristics (thermal dissipation curve).

Since the IC itself is designed with full consideration of thermal balance, there are no problems in terms of circuit operations, but even when a more-than-adequate thermal design is implemented in order to get full use of the IC's performance features, some moderation is often required for the sake of practical usage.

If there is an excessive input signal due to insufficient thermal dissipation, a TSD (thermal shutdown) operation may occur.

Thermal Dissipation Curve

Reference data

VSON008V2030

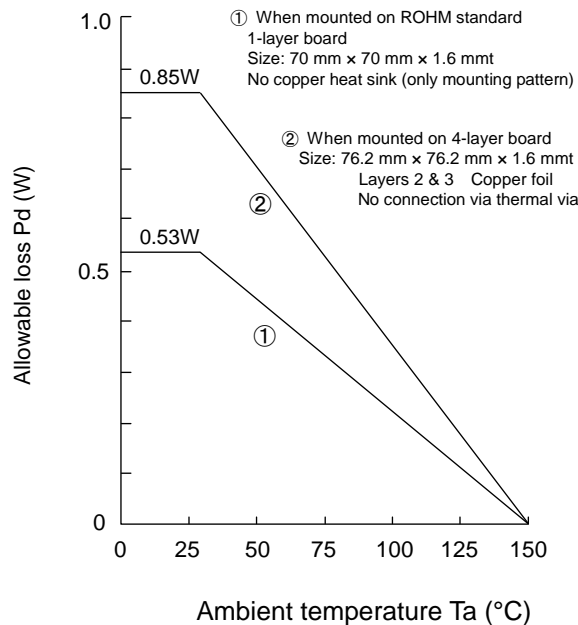

(Note) These are measured values. They are not guaranteed.

The allowable loss value varies depending on the type of board used for mounting. When this chip is mounted on a multi-layer board that is designed for thermal dissipation, the allowable loss becomes greater than shown in the above figure.

● Cautions on use

- (1) The above numerical values and data are typical values for the design, which are not guaranteed.
- (2) The application circuit examples can be reliably recommended, but their characteristics should be checked carefully before use. When using external component constants that have been modified, determine an ample margin that takes into consideration variation among the external components and Rohm's LSI IC chips, including variation in static characteristics and transient characteristics.
- (3) Absolute maximum ratings
This IC may be damaged if the absolute maximum ratings for the applied voltage, temperature range, or other parameters are exceeded. Therefore, avoid using a voltage or temperature that exceeds the absolute maximum ratings. If it is possible that absolute maximum ratings will be exceeded, use fuses or other physical safety measures and determine ways to avoid exceeding the IC's absolute maximum ratings. The above numerical values and data are typical values for the design, which are not guaranteed.
- (4) GND pin's potential
Try to set the minimum voltage for GND pin's potential, regardless of the operation mode.
Check that the voltage of each pin does not go below GND pin's voltage, including transient phenomena.
- (5) Shorting between pins and mounting errors
When mounting the IC chip on a board, be very careful to set the chip's orientation and position precisely.
When the power is turned on, the IC may be damaged if it is not mounted correctly. The IC may also be damaged if a short occurs (due to a foreign object, etc.) between two pins, between a pin and the power supply, or between a pin and the GND.
- (6) Shorting output pin
When output pin(5,8pin) is shorted to VCC or GND, the IC may be damaged by over current, so be careful in operation.
- (7) Thermal design
Ensure sufficient margins to the thermal design by taking in to account the allowable power dissipation during actual use modes, because this IC is power amp.
When excessive signal inputs which the heat dissipation is insufficient condition, it is possible that TSD(thermal shutdown circuit) is active.
TSD is protection of the heat by excessive signal inputs, it is not protection of the shorting output to VCC or GND.
- (8) Shorted pins and mounting errors
When the output pins (pins 5 and 8) are connected to VCC and GND, the thermal shutdown function repeatedly switches between shutdown (OFF) and cancel (ON). Note with caution that chip damage may occur if these connections remain for a long time.
- (9) Operating range
The rated operating power supply voltage range(VCC=+2.4~+5.5V) and the rated operation temperature range (Ta=-40~+85°C) are the range by which basic circuit functions is operated.
It is not guaranteed a specification and a rated output power about all operating power supply voltage range or operation temperature range.
- (10) Operation in strong magnetic fields
Note with caution that operation faults may occur when this IC operates in a strong magnetic field.

● Typical Characteristics (1)

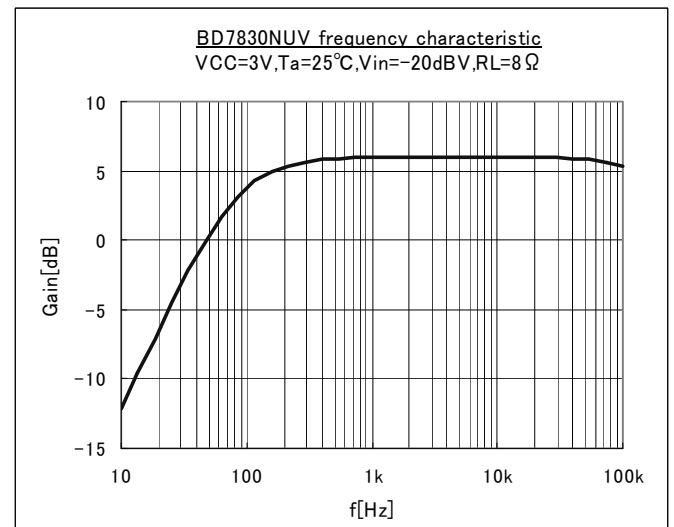
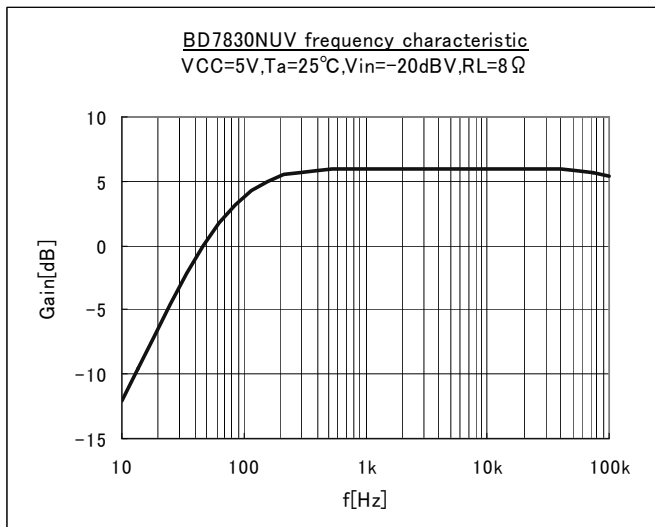
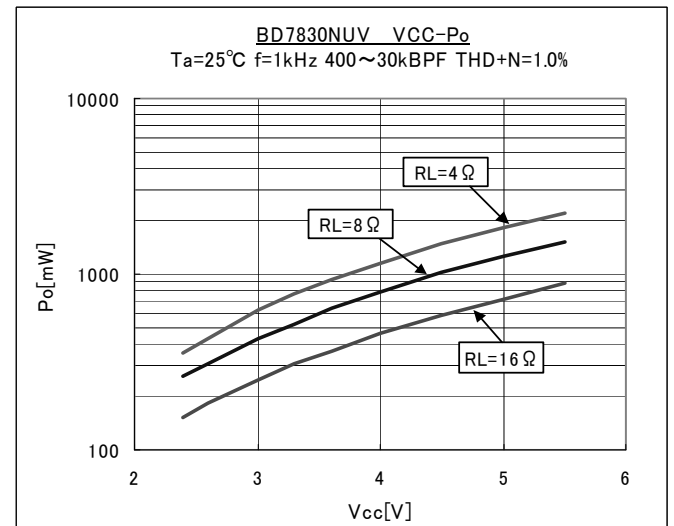
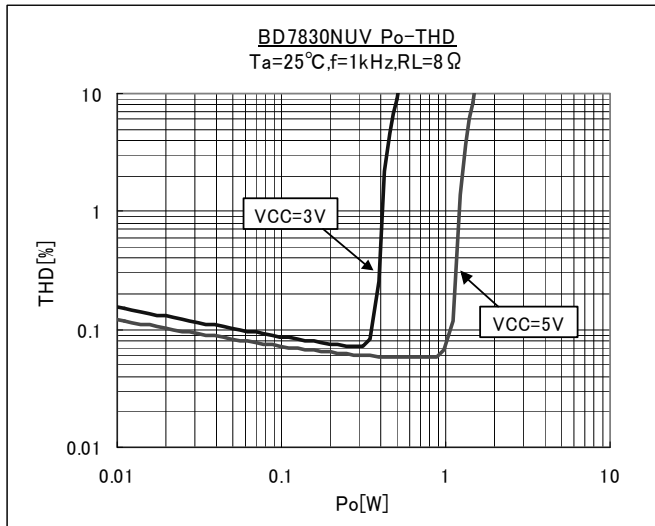
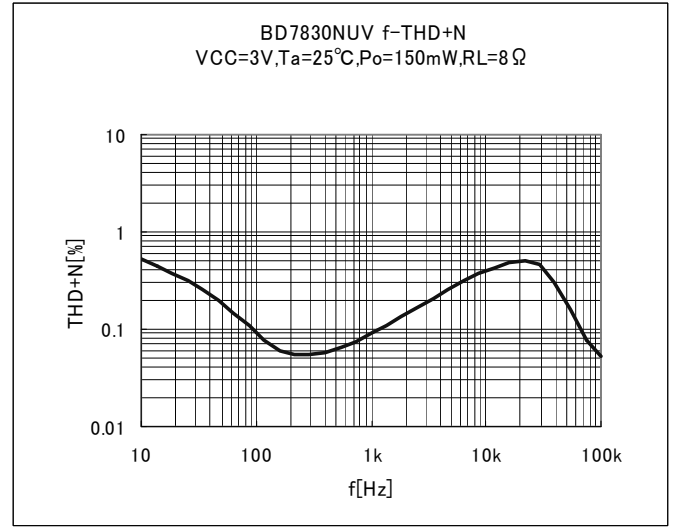
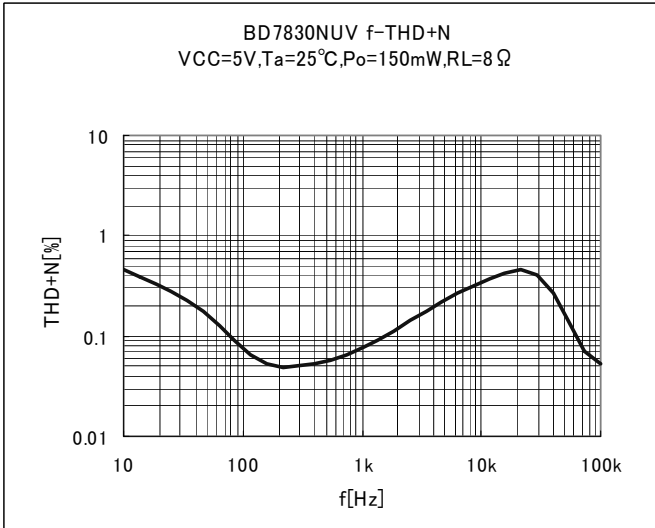

● Typical Characteristics (2)

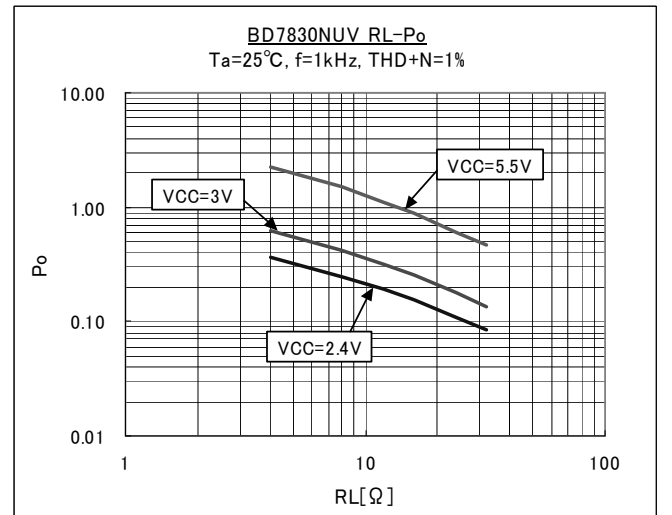
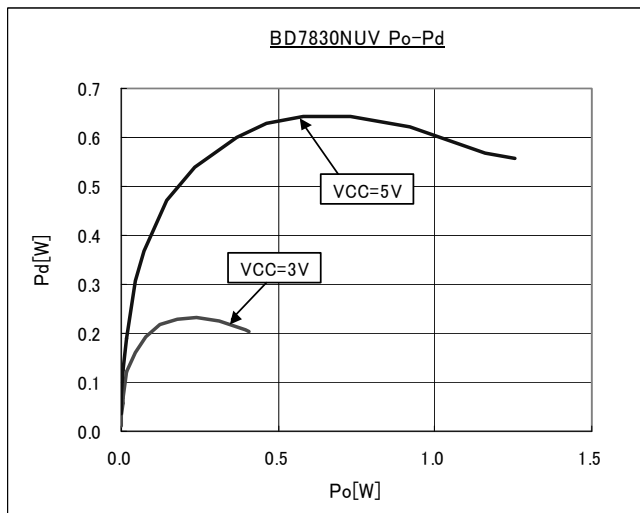
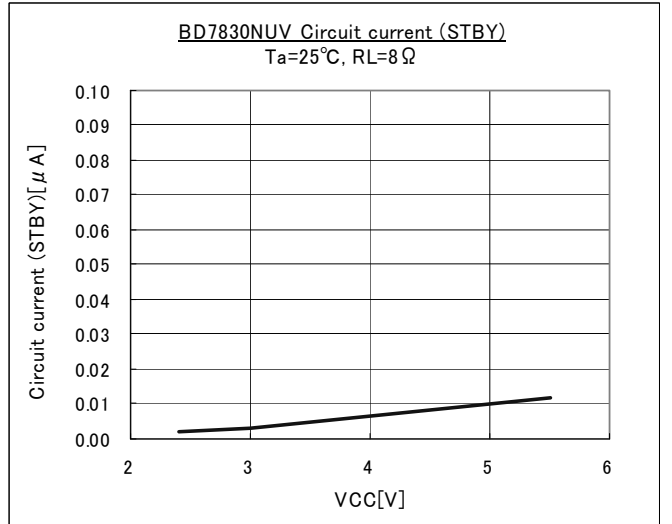
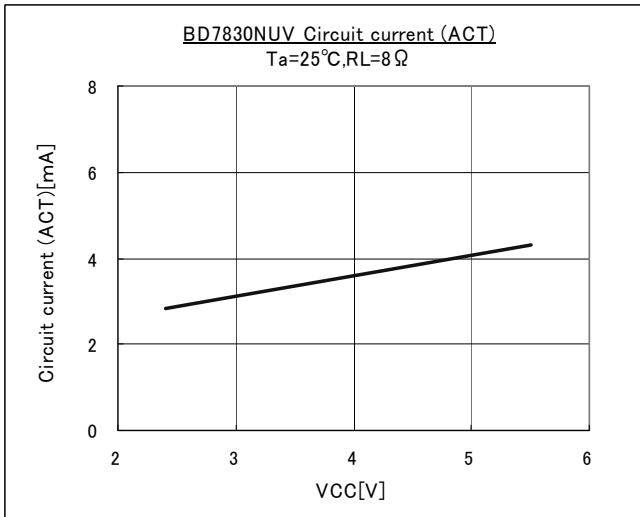
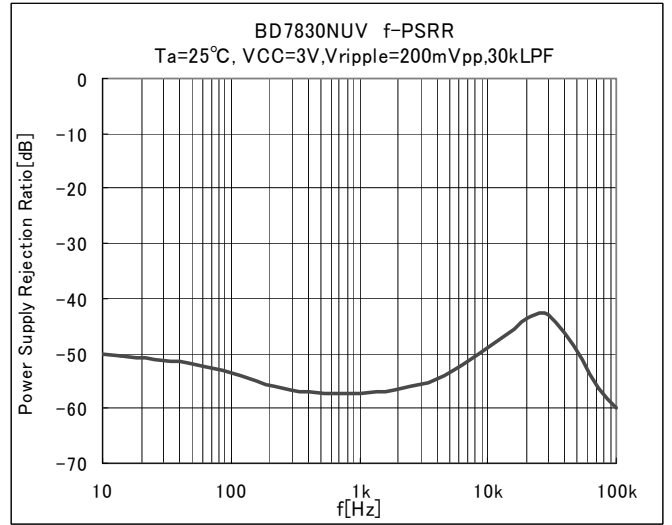
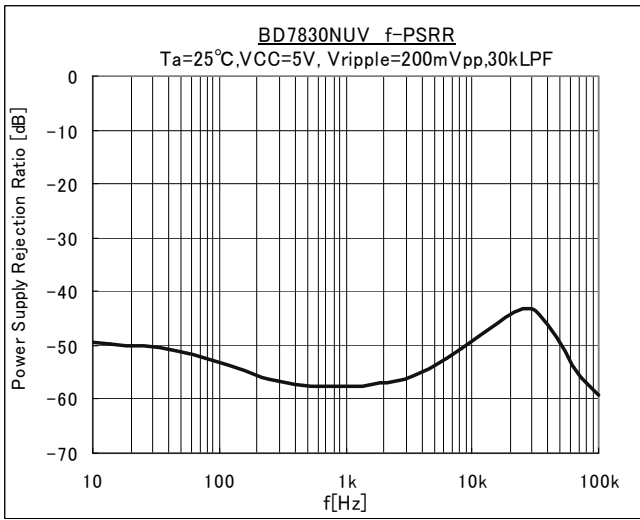

● Selection of order type



VSON008V2030

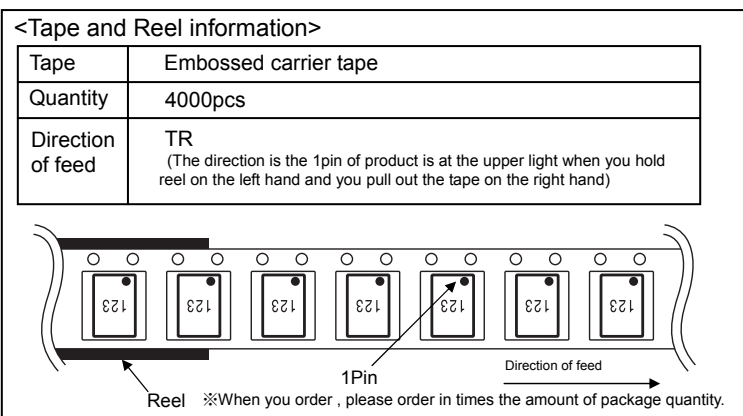
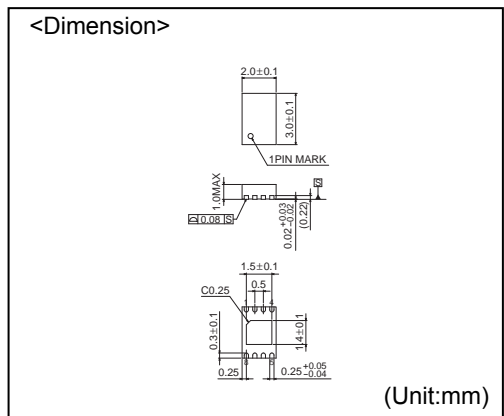

- The contents described herein are correct as of August, 2008
- The contents described herein are subject to change without notice. For updates of the latest information, please contact and confirm with ROHM CO.,LTD.
- Any part of this application note must not be duplicated or copied without our permission.
- Application circuit diagrams and circuit constants contained herein are shown as examples of standard use and operation. Please pay careful attention to the peripheral conditions when designing circuits and deciding upon circuit constants in the set.
- Any data, including, but not limited to application circuit diagrams and information, described herein are intended only as illustrations of such devices and not as the specifications for such devices. ROHM CO.,LTD. disclaims any warranty that any use of such devices shall be free from infringement of any third party's intellectual property rights or other proprietary rights, and further, assumes no liability of whatsoever nature in the event of any such infringement, or arising from or connected with or related to the use of such devices.
- Upon the sale of any such devices, other than for buyer's right to use such devices itself, resell or otherwise dispose of the same, implied right or license to practice or commercially exploit any intellectual property rights or other proprietary rights owned or controlled by ROHM CO., LTD. is granted to any such buyer.
- The products described herein utilize silicon as the main material.
- The products described herein are not designed to be X ray proof.

The products listed in this catalog are designed to be used with ordinary electronic equipment or devices (such as audio visual equipment, office-automation equipment, communications devices, electrical appliances and electronic toys). Should you intend to use these products with equipment or devices which require an extremely high level of reliability and the malfunction of which would directly endanger human life (such as medical instruments, transportation equipment, aerospace machinery, nuclear-reactor controllers, fuel controllers and other safety devices), please be sure to consult with our sales representative in advance.

Contact us for further information about the products.

San Diego	TEL: +1-858-625-3630	FAX: +1-858-625-3670	Tianjin	TEL: +86-22-23029181	FAX: +86-22-23029183
Atlanta	TEL: +1-770-754-5972	FAX: +1-770-754-0691	Shanghai	TEL: +86-21-6279-2727	FAX: +86-21-6247-2066
Boston	TEL: +1-978-371-0382	FAX: +1-928-438-7164	Hangzhou	TEL: +86-571-87658072	FAX: +86-571-87658071
Chicago	TEL: +1-847-368-1006	FAX: +1-847-368-1008	Nanjing	TEL: +86-25-8689-0015	FAX: +86-25-8689-0393
Dallas	TEL: +1-469-287-5366	FAX: +1-469-362-7973	Ningbo	TEL: +86-574-87654201	FAX: +86-574-87654208
Denver	TEL: +1-303-708-0908	FAX: +1-303-708-0858	Qingdao	TEL: +86-532-5779-312	FAX: +86-532-5779-653
Detroit	TEL: +1-248-348-9920	FAX: +1-248-348-9942	Suzhou	TEL: +86-510-82702693	FAX: +86-510-82702992
Nashville	TEL: +1-615-620-6700	FAX: +1-615-620-6702	Wuxi	TEL: +86-510-82702693	FAX: +86-510-82702992
Mexico	TEL: +52-33-3123-2001	FAX: +52-33-3123-2002	Shenzhen	TEL: +86-755-8307-3008	FAX: +86-755-8307-3003
Düsseldorf	TEL: +49-2154-9210	FAX: +49-2154-921400	Dongguan	TEL: +86-769-8393-3320	FAX: +86-769-8398-4140
Munich	TEL: +49-8999-216168	FAX: +49-8999-216176	Fuzhou	TEL: +86-591-8801-8698	FAX: +86-591-8801-8690
Stuttgart	TEL: +49-711-7272-370	FAX: +49-711-7272-3720	Guangzhou	TEL: +86-20-3878-8100	FAX: +86-20-3825-5965
France	TEL: +33-1-5697-3060	FAX: +33-1-5697-3080	Huizhou	TEL: +86-752-205-1054	FAX: +86-752-205-1059
United Kingdom	TEL: +44-1-908-306700	FAX: +44-1-908-235788	Xiamen	TEL: +86-592-238-5705	FAX: +86-592-239-8380
Denmark	TEL: +45-3694-4739	FAX: +45-3694-4789	Zhuhai	TEL: +86-756-3232-480	FAX: +86-756-3232-460
Espoo	TEL: +358-9725-54491	FAX: +358-9-7255-4499	Hong Kong	TEL: +852-2-740-6262	FAX: +852-2-375-8971
Salo	TEL: +358-2-7332234	FAX: +358-2-7332237	Taipei	TEL: +886-2-2500-6956	FAX: +886-2-2503-2869
Oulu	TEL: +358-8-5372930	FAX: +358-8-5372931	Kaohsiung	TEL: +886-7-237-0881	FAX: +886-7-238-7332
Barcelona	TEL: +34-9375-24320	FAX: +34-9375-24410	Singapore	TEL: +65-6332-2322	FAX: +65-6332-5662
Hungary	TEL: +36-1-4719338	FAX: +36-1-4719339	Philippines	TEL: +63-2-807-6872	FAX: +63-2-809-1422
Poland	TEL: +48-22-5757213	FAX: +48-22-5757001	Thailand	TEL: +66-2-254-4890	FAX: +66-2-256-6334
Russia	TEL: +7-495-739-41-74	FAX: +7-495-739-41-74	Kuala Lumpur	TEL: +60-3-7958-8355	FAX: +60-3-7958-8377
Seoul	TEL: +82-2-8182-700	FAX: +82-2-8182-715	Penang	TEL: +60-4-2286453	FAX: +60-4-2286452
Masan	TEL: +82-55-240-6234	FAX: +82-55-240-6236	Kyoto	TEL: +81-75-365-1218	FAX: +81-75-365-1228
Dalian	TEL: +86-411-8230-8549	FAX: +86-411-8230-8537	Yokohama	TEL: +81-45-476-2290	FAX: +81-45-476-2295
Beijing	TEL: +86-10-8525-2483	FAX: +86-10-8525-2489			

Excellence in Electronics



ROHM CO., LTD.

21 Saiin Mizosaki-cho, Ukyo-ku, Kyoto
615-8585, Japan
TEL: +81-75-311-2121 FAX: +81-75-315-0172
URL: <http://www.rohm.com>

Published by
KTC LSI Development Headquarters
LSI Business Promotion Group

Notes

- No technical content pages of this document may be reproduced in any form or transmitted by any means without prior permission of ROHM CO.,LTD.
- The contents described herein are subject to change without notice. The specifications for the product described in this document are for reference only. Upon actual use, therefore, please request that specifications to be separately delivered.
- Application circuit diagrams and circuit constants contained herein are shown as examples of standard use and operation. Please pay careful attention to the peripheral conditions when designing circuits and deciding upon circuit constants in the set.
- Any data, including, but not limited to application circuit diagrams information, described herein are intended only as illustrations of such devices and not as the specifications for such devices. ROHM CO.,LTD. disclaims any warranty that any use of such devices shall be free from infringement of any third party's intellectual property rights or other proprietary rights, and further, assumes no liability of whatsoever nature in the event of any such infringement, or arising from or connected with or related to the use of such devices.
- Upon the sale of any such devices, other than for buyer's right to use such devices itself, resell or otherwise dispose of the same, no express or implied right or license to practice or commercially exploit any intellectual property rights or other proprietary rights owned or controlled by
- ROHM CO., LTD. is granted to any such buyer.
- Products listed in this document are no antiradiation design.

The products listed in this document are designed to be used with ordinary electronic equipment or devices (such as audio visual equipment, office-automation equipment, communications devices, electrical appliances and electronic toys).

Should you intend to use these products with equipment or devices which require an extremely high level of reliability and the malfunction of which would directly endanger human life (such as medical instruments, transportation equipment, aerospace machinery, nuclear-reactor controllers, fuel controllers and other safety devices), please be sure to consult with our sales representative in advance.

It is our top priority to supply products with the utmost quality and reliability. However, there is always a chance of failure due to unexpected factors. Therefore, please take into account the derating characteristics and allow for sufficient safety features, such as extra margin, anti-flammability, and fail-safe measures when designing in order to prevent possible accidents that may result in bodily harm or fire caused by component failure. ROHM cannot be held responsible for any damages arising from the use of the products under conditions out of the range of the specifications or due to non-compliance with the NOTES specified in this catalog.

Thank you for your accessing to ROHM product informations.

More detail product informations and catalogs are available, please contact your nearest sales office.

ROHM Customer Support System

THE AMERICAS / EUROPE / ASIA / JAPAN

www.rohm.com

Contact us : webmaster@rohm.co.jp