



Typical unit

### FEATURES

- Small footprint DC/DC converter, ideal for high current applications
- Industry standard 1.50" x 1.90" x 0.38" open frame package and pinout
- Wide range input voltages 9-36 and 18-75Vdc
- Assembly and attachment for RoHS standards
- Isolation up to 2250 VDC (basic)
- Up to 50-60W total output power with overtemperature shutdown
- High efficiency synchronous rectifier forward topology
- Stable no-load operation with no required external components
- -40 to +85°C temperature range with derating
- Meets UL60950-1, CSA-C22.2 No. 234, EN60950-1, 2nd Edition safety approvals
- Extensive self-protection shut down features
- RoHS-6 compliant

Featuring a full 50-60 Watt output in 2.9 square inches of board area, the UEI series isolated DC/DC converter family offers efficient regulated DC power for printed circuit board mounting.

### PRODUCT OVERVIEW

Wide range 4:1 inputs on the 1.50" x 1.90" x 0.38" converter are either 9 to 36 Volts DC (Q12 models) or 18 to 75 Volts DC (Q48 models), ideal for battery-powered and telecom equipment. Fixed output voltages from 3.3 VDC to 15 VDC are regulated to within  $\pm 0.05\%$  and may be trimmed within  $\pm 10\%$  of nominal output. Applications include small instruments, computer-based systems, data communications equipment, remote sensor systems, vehicle and portable electronics.

The UEI 50-60W Series includes full magnetic and optical isolation up to 2250 Volts DC (basic insulation). For connection to digital systems, the outputs offer fast settling to current step loads and tolerance of higher capacitive loads. Excellent ripple and noise specifications assure compatibility to circuits using CPU's, ASIC's, programmable

logic and FPGA's. No minimum load is required. For systems requiring controlled startup/shutdown, an external switch, transistor or digital logic may be used to activate the remote On/Off control. Remote Sense inputs compensate for resistive line drops at high currents.

A wealth of self-protection features avoid both converter and external circuit problems. These include input undervoltage lockout, input overvoltage and overtemperature shutdown. The outputs current limit using the "hiccup" autorestart technique and the outputs may be short-circuited indefinitely. Additional features include output overvoltage and reverse conduction elimination. The synchronous rectifier forward topology offers high efficiency for minimal heat buildup and "no fan" operation.

### SIMPLIFIED SCHEMATIC

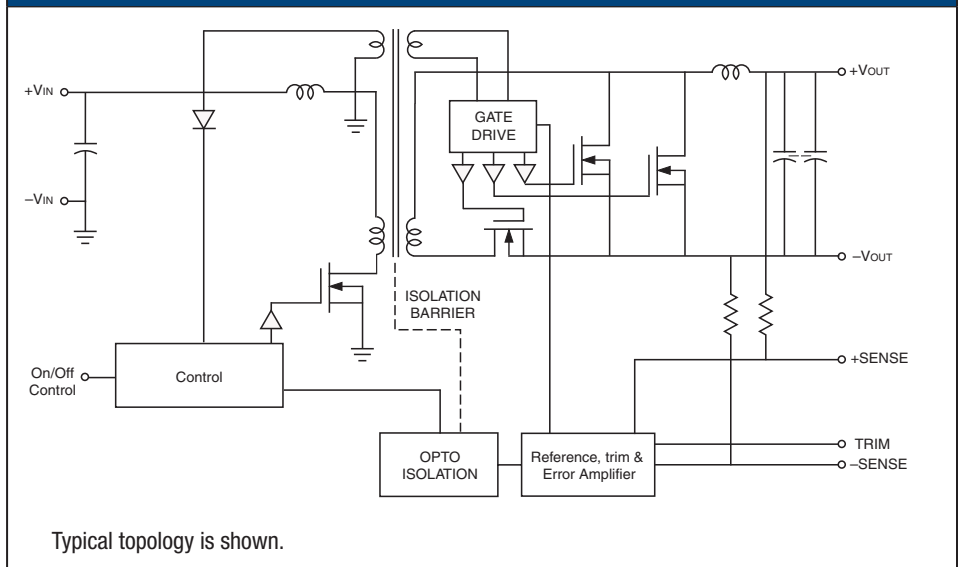

PERFORMANCE SPECIFICATIONS AND ORDERING GUIDE																
Root Model <sup>①</sup>	Output							Input				Efficiency		Sense Input	Package	
	V <sub>OUT</sub> (V)	I <sub>OUT</sub> (A)	Power	R/N (mVp-p)		Regulation (Max.)		V <sub>IN</sub> Nom. (V)	Range (V)	I <sub>IN</sub> , no load (mA)	I <sub>IN</sub> , full load (A)	Min.	Typ.		Case	Pinout
			(W)	Typ.	Max.	Line	Load									
UEI-3.3/15-Q12PR-C	3.3	15.0	49.5	15	30	±0.05%	±0.06%	24	9-36	130	2.33	86.8%	88.5%	yes	C74	P52
UEI-3.3/18-Q48NR-C	3.3	18.0	59.4	60	125	±0.075%	±0.2%	48	18-75	130	1.38	87%	89.5%	yes	C74	P52
UEI-5/10-Q12PR-C	5	10.0	50.0	35	50	±0.1%	±0.1%	24	9-36	130	2.31	89%	90%	yes	C74	P52
UEI-5/12-Q48NR-C	5	12.0	60.0	70	100	±0.1%	±0.15%	48	18-75	130	1.37	89.5%	91%	yes	C74	P52
UEI-12/4.2-Q12P-C	12	4.2	50.4	50	120	±0.05%	±0.05%	24	9-36	130	2.35	87.8%	89.5%	no	C74	P51
UEI-12/5-Q48N-C	12	5.0	60.0	40	70	±0.05%	±0.05%	48	18-75	130	1.42	87%	89.8%	no	C74	P51
UEI-15/3.3-Q12P-C	15	3.3	49.5	30	100	±0.075%	±0.05%	24	9-36	130	2.29	88.3%	90%	no	C74	P51
UEI-15/4-Q48N-C	15	4.0	60.0	35	60	±0.075%	±0.05%	48	18-75	50	1.40	87.5%	89.3%	no	C74	P51

- ① These are partial model numbers. Please refer to the full model number structure for complete ordering part numbers.
- ② Sense input is not included for 12 V<sub>OUT</sub> and higher models. Sense is optional for 5 V<sub>OUT</sub> and lower.
- ③ All specifications are typical at nominal line voltage and full load, +25 deg.C. unless otherwise noted. See detailed specifications.

- ④ Output capacitors are 1 µF ceramic || 10 µF electrolytic. Input cap is 22 µF, low ESR.
- ⑤ I/O caps are necessary for our test equipment and may not be needed for your application.

### PART NUMBER STRUCTURE

**UEI - 3.3 / 15 - Q12 P R - C**

- Nominal Output Voltage:** 3.3, 15
- Maximum Rated Output Current in Amps:** 15
- Input Voltage Range:**
  - Q12 = 9-36V
  - Q48 = 18-75V
- On/Off Control Polarity:**
  - P = Positive
  - N = Negative
- Sense Inputs (5 V<sub>OUT</sub> and lower):**
  - R = Sense included as standard (for 5 V<sub>OUT</sub> and lower models only. 12 V<sub>OUT</sub> and higher models do not offer the sense option.)
  - Blank = Sense not installed for 5 V<sub>OUT</sub> and lower models. Pins 5 and 8 omitted.
- RoHS-6 Hazardous Substance Compliance**  
(does not claim EU RoHS exemption 7b—lead in solder)

**Note:**  
Not all model number combinations are available. Contact Murata Power Solutions.

### Soldering Guidelines

Murata Power Solutions recommends the specifications below when installing these converters. These specifications vary depending on the solder type. Exceeding these specifications may cause damage to the product. Your production environment may differ; therefore please thoroughly review these guidelines with your process engineers.

Wave Solder Operations for through-hole mounted products (THMT)			
For Sn/Ag/Cu based solders:		For Sn/Pb based solders:	
Maximum Preheat Temperature	115° C.	Maximum Preheat Temperature	105° C.
Maximum Pot Temperature	270° C.	Maximum Pot Temperature	250° C.
Maximum Solder Dwell Time	7 seconds	Maximum Solder Dwell Time	6 seconds

**MECHANICAL SPECIFICATIONS**

INPUT/OUTPUT CONNECTIONS, WITH SENSE			
Pin	Function P52	Pin	Function P52
		5	+Sense In
1	Positive Input	6	Positive Output
2	Negative Input		No pin
3	No pin	7	Negative Output
4	On/Off Control In	8	-Sense In
		9	Trim

Important: If sense inputs are not connected to a remote load, connect them to their respective  $V_{OUT}$  pins at the converter.

INPUT/OUTPUT CONNECTIONS, WITHOUT SENSE			
Pin	Function P51	Pin	Function P51
		5	No pin
1	Positive Input	6	Positive Output
2	Negative Input		No pin
3	No pin	7	Negative Output
4	On/Off Control In	8	No pin
		9	Trim

Pins 5 and 8 are omitted for models without sense inputs.

PHYSICAL CHARACTERISTICS	
Outline dimensions	See mechanical specs
Pin material	Copper alloy with gold plate over nickel underplate
Pin diameter	0.04" (1mm)
Pin Finish	Gold plate
Weight	1 oz (28.5g)
Electromagnetic interference	Meets class B, EN55022 (requires external filter)
Flammability Rating	UL 94V-0
Safety	Meets IEC/EN/UL/cUL 60950-1, CSA-C22.2 No. 60950-1, 2nd Edition

Dimensions are in inches (mm shown for ref. only).

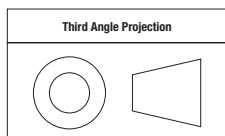

Tolerances (unless otherwise specified):  
 .XX ± 0.02 (0.5)  
 .XXX ± 0.010 (0.25)  
 Angles ± 2°

Components are shown for reference only.

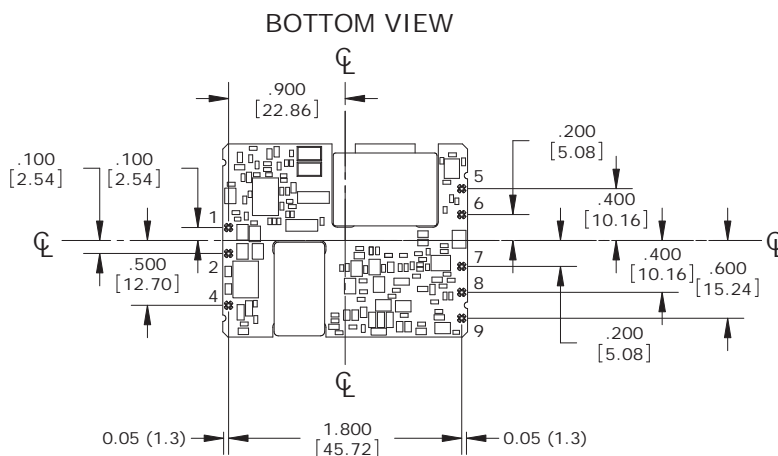
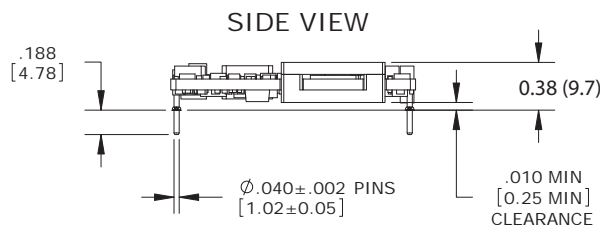
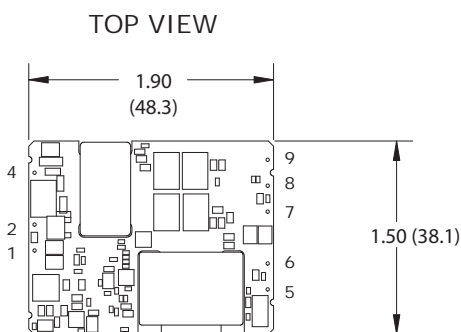

UEI50 Open Frame  
 50-60W  
 Case C74

INPUT CHARACTERISTICS														
Model Family	VIN	Start-up threshold	Under-voltage Shut-down	Reflected (back) Ripple Current <sup>2</sup>	Input Current				Recommended Fuse	Internal Input Filter Type	Reverse Polarity Protection	Remote On/Off Control		
					Inrush Transient	Output Short Circuit	Low Line	Standby Mode				On/Off Current	Positive Logic	Negative Logic
					A <sup>2</sup> sec	mA	A	mA				mA	"P" model suffix	"N" model suffix
UEI-3.3/15-Q12	24	9.5	8.5	30	0.05	50	6.25	1	12	L-C	None - see notes	1	OFF=Gnd pin or -0.7 to +1.2V max. ON=open pin or +10 to +15V max.	OFF=open pin or +10 to +15V max. ON=Gnd pin or -0.7 to +1.2V max.
UEI-3.3/18-Q48	48	17.3	16.0				3.71		6					
UEI-5/10-Q12	24	9.5	8.5				6.21		12					
UEI-5/12-Q48	48	17.3	16.0*				3.70		6					
UEI-12/4.2-Q12	24	9.5	8.5				6.31		10					
UEI-12/5-Q48	48	17.5	16.7				3.88		6					
UEI-15/3.3-Q12	24	9.5	8.5	45			6.15		9					
UEI-15/4-Q48	48	17.2	16.3	30			3.77		6					

\*At 50% load

OUTPUT CHARACTERISTICS															
Model Family	I <sub>OUT</sub> Max.	V <sub>OUT</sub> Accuracy		Adjustment Range	Temperature Coefficient	Remote Sense Compensation	Capacitive Loading Max.		Overvoltage protection		Minimum loading	OV protection method	Ripple/Noise (20 MHz bandwidth) <sup>8</sup>	Line/Load Regulation	Efficiency
		50% Load					Low ESR <0.02Ω Max, resistive load	Hiccup auto-start after fault removal							
		A	% of V <sub>NOM</sub>				μF	V							
UEI-3.3/15-Q12	15	±2		±10	±0.02	+5	2,000	3.9	No minimum load	Magnetic feedback	See ordering guide				
UEI-3.3/18-Q48	18		+5			3.9									
UEI-5/10-Q12	10		+5			5.9									
UEI-5/12-Q48	12		+5			6.4									
UEI-12/4.2-Q12	4.2	±1				16.5									
UEI-12/5-Q48	5		Not Available			16									
UEI-15/3.3-Q12	3.3			24											
UEI-15/4-Q48	4			21.5											

ABSOLUTE MAXIMUM RATINGS			
Input Voltage	Q12 models	Volts, max. continuous	0-36 VDC to rated specifications
		Volts, transient, 100 mSec	50 VDC, no damage
	Q48 models	Volts, max. continuous	0-75 VDC to rated specifications
		Volts, transient, 100 mSec	100 VDC, no damage
On/Off control, referred to -Vin			-0.7 V. min to +15V max.
Input Reverse Polarity Protection			See fuse section
Output Overvoltage			V <sub>OUT</sub> nom. +20% max.
Output Current			Current-limited. Devices can withstand sustained short circuit without damage. The outputs are not intended to accept appreciable reverse current.
Overtemperature Protection			Device includes electronic over-temperature shutdown protection under normal operation.
Storage Temperature			-55 to +125° C.
Lead Temperature			See soldering specifications

**Absolute Maximum Ratings**

Absolute maximums are stress ratings. Exposure of devices to greater than any of these conditions may adversely affect long-term reliability. Proper operation under conditions other than those listed in the Performance/Functional Specifications Table is not implied nor recommended.

**Maximum Ratings Notes**

The UEI-50/60W series does not include electronic Input Overvoltage Protection. Therefore it is possible for the input to exceed the continuous ratings listed above and still operate. However, units are not routinely Production-tested above the continuous ratings. Therefore, the rated specifications do not apply at excessive input voltage and performance is undetermined.

The transient specifications indicate that sample lots were successfully tested for 100 mS at the transient stress voltage and were not damaged. As a practical matter in your application, it is often difficult to determine how long an input overvoltage was applied. Therefore, do not exceed the continuous voltage rating.

ISOLATION CHARACTERISTICS				
Model Family	Input to Output	Isolation Resistance	Isolation Capacitance	Isolation Safety Rating
	Min	Min		
	VDC	MΩ	pF	
UEI-3.3/15-Q12	2000	10	1000	Basic insulation
UEI-3.3/18-Q48	2250	10		
UEI-5/10-Q12	2000	10		
UEI-5/12-Q48	2250	10		
UEI-12/4.2-Q12	2000	10		
UEI-12/5-Q48	2250	10		
UEI-15/3.3-Q12	2000	10		
UEI-15/4-Q48	2250	10		

DYNAMIC CHARACTERISTICS				
Model Family	Dynamic Load Response (50-75-50% load step)	Start-up Time		Switching Frequency
		V <sub>IN</sub> to V <sub>OUT</sub> regulated (Max.)	Remote On/Off to V <sub>OUT</sub> regulated (Max.)	
		μsec	mSec	
UEI-3.3/15-Q12	100 to 2% V <sub>OUT</sub>	50	50	275
UEI-3.3/18-Q48	180 to 2% V <sub>OUT</sub>			280
UEI-5/10-Q12	200 to 2% V <sub>OUT</sub>			275
UEI-5/12-Q48	100 to 2% V <sub>OUT</sub>			
UEI-12/4.2-Q12	200 to 1% V <sub>OUT</sub>			250
UEI-12/5-Q48	400 to 1% V <sub>OUT</sub>			265
UEI-15/3.3-Q12	150 to 1% V <sub>OUT</sub>			255
UEI-15/4-Q48	150 to 1% V <sub>OUT</sub>			

MISCELLANEOUS CHARACTERISTICS											
Model Family	Output Current Limit Inception	Output Short Circuit Protection Method	Output Short Circuit Current	Output Short Circuit Duration (output shorted to ground)	Pre-biased setup	Calculated MTBF	Operating Temperature Range	Storage temperature range	Thermal protection/shutdown	Relative Humidity, non-condensing	
	98% of V <sub>OUT</sub> , after warmup										A
	A										Hours
UEI-3.3/15-Q12	20	Current limiting, hiccup auto restart	0.5	Continuous	Monotonic (external V <sub>OUT</sub> < V <sub>SET</sub> )	2,000,000	-40 to +85°C; with Derating (see Notes)	-55 to 125°C	115	To +85°C/85%	
UEI-3.3/18-Q48	23										
UEI-5/10-Q12	13										
UEI-5/12-Q48	15.5										
UEI-12/4.2-Q12	6										
UEI-12/5-Q48	6.1										
UEI-15/3.3-Q12	5.3										
UEI-15/4-Q48	5.8										

**Specification Notes:**

- (1) All models are tested and specified with external 11110 μF output capacitors and a 22 μF external input capacitor. All capacitors are low ESR types. These capacitors are necessary to accommodate our test equipment and may not be required to achieve specified performance in your applications. All models are stable and regulate within spec under no-load conditions. All specifications are typical unless noted. General conditions for Specifications are +25 deg.C, V<sub>IN</sub>=nominal, V<sub>OUT</sub>=nominal, full load. Adequate airflow must be supplied for extended testing under power.
- (2) Input Back Ripple Current is tested and specified over a 5 Hz to 20 MHz bandwidth. Input filtering is C<sub>in</sub>=33 μF, 100V, C<sub>bus</sub>=220 μF, 100V, L<sub>bus</sub>=12 μH.
- (3) Note that Maximum Power Derating curves indicate an *average* current at nominal input voltage. At higher temperatures and/or lower airflow, the DC/DC converter will tolerate brief full current outputs if the total RMS current over time does not exceed the Derating curve. All Derating curves are presented at sea level altitude. Be aware of reduced power dissipation with increasing density altitude.
- (4) Mean Time Before Failure is calculated using the Telcordia (Belcore) SR-332 Method 1, Case 3, ground fixed conditions, T<sub>pcboard</sub>=+25 deg.C, full load, natural air convection.
- (5) The On/Off Control is normally selected by a switch or an open collector or open drain transistor. But it may also be driven with external logic or by applying appropriate external voltages which are referenced to Input Common and do not exceed the On/Off voltage specifications.
- (6) Output current limiting begins when the output voltage degrades approximately 2% from the selected setting.
- (7) The outputs are not intended to sink appreciable reverse current.
- (8) Output noise may be further reduced by adding an external filter. Low voltage logic circuits may have a small voltage margin between logic ZERO and logic ONE, requiring noise suppression. *Use only*

as much output filtering as needed to achieve your noise requirements. Excessive output capacitance can retard transient response or possibly cause instability. Low ESR ceramic capacitors may degrade dynamic performance. Be sure to thoroughly test your system under full load with all components installed.

- (9) All models are fully operational and meet published specifications, including "cold start" at -40°C.
  - (10) Regulation specifications describe the deviation as the line input voltage or output load current is varied from a nominal midpoint value to either extreme.
  - (11) The output overvoltage protection is automatic recovery. The overvoltage may occur either from internal failure or from an external forcing voltage as in a shared power system.
  - (12) Output current limit and short circuit protection is non-latching. When the overcurrent fault is removed, the converter will immediately recover. After an output overcurrent or short circuit, "hiccup" operation repeatedly attempts to restart the converter with a brief, full-current output. If the overcurrent condition still exists, the restart current will be removed and then tried again. This short current pulse prevents overheating and damaging the converter. Once the fault is removed, the converter immediately resumes normal operation.
  - (13) Do not exceed maximum power specifications when adjusting the output trim.
  - (14) At zero output current, the output may contain low frequency components which exceed the ripple specification. The output may be operated indefinitely with no load.
  - (15) If reverse polarity is accidentally applied to the input, to ensure reverse input protection with full output load, always connect an external input **fuse** in series with the +V<sub>IN</sub> input. Use approximately twice the full input current rating with nominal input voltage.
- CAUTION:** This product is not internally fused. To comply with safety agency certifications and to avoid injury to personnel or equipment, the user **must** connect an external fast-blow fuse to the input terminals. See fuse information.

**APPLICATION NOTES**

**Input Fusing**

Certain applications and/or safety agencies may require fuses at the inputs of power conversion components. Fuses should also be used when there is the possibility of sustained input voltage reversal which is not current-limited. We recommend a time delay fuse installed in the ungrounded input supply line with a value which is approximately twice the maximum line current, calculated at the lowest input voltage.

The installer must observe all relevant safety standards and regulations. For safety agency approvals, install the converter in compliance with the end-user safety standard, i.e. IEC/EN/UL 60950-1.

**Input Reverse-Polarity Protection**

If the input voltage polarity is reversed, an internal diode will become forward biased and likely draw excessive current from the power source. If this source is not current-limited or the circuit appropriately fused, it could cause permanent damage to the converter.

**Input Under-Voltage Shutdown and Start-Up Threshold**

Under normal start-up conditions, converters will not begin to regulate properly until the ramping-up input voltage exceeds and remains at the Start-Up Threshold Voltage (see Specifications). Once operating, converters will not turn off until the input voltage drops below the Under-Voltage Shutdown Limit. Subsequent restart will not occur until the input voltage rises again above the Start-Up Threshold. This built-in hysteresis prevents any unstable on/off operation at a single input voltage.

Users should be aware however of input sources near the Under-Voltage Shutdown whose voltage decays as input current is consumed (such as capacitor inputs), the converter shuts off and then restarts as the external capacitor recharges. Such situations could oscillate. To prevent this, make sure the operating input voltage is well above the UV Shutdown voltage AT ALL TIMES.

**Start-Up Time**

Assuming that the output current is set at the rated maximum, the Vin to Vout Start-Up Time (see Specifications) is the time interval between the point when the ramping input voltage crosses the Start-Up Threshold and the fully loaded regulated output voltage enters and remains within its specified accuracy band. Actual measured

times will vary with input source impedance, external input capacitance, input voltage slew rate and final value of the input voltage as it appears at the converter.

These converters include a soft start circuit to moderate the duty cycle of its PWM controller at power up, thereby limiting the input inrush current.

The On/Off Remote Control interval from On command to Vout regulated assumes that the converter already has its input voltage stabilized above the Start-Up Threshold before the On command. The interval is measured from the On command until the output enters and remains within its specified accuracy band. The specification assumes that the output is fully loaded at maximum rated current. Similar conditions apply to the On to Vout regulated specification such as external load capacitance and soft start circuitry.

**Input Source Impedance**

These converters will operate to specifications without external components, assuming that the source voltage has very low impedance and reasonable input voltage regulation. Since real-world voltage sources have finite impedance, performance is improved by adding external filter components. Sometimes only a small ceramic capacitor is sufficient. Since it is difficult to totally characterize all applications, some experimentation may be needed. Note that external input capacitors must accept high speed switching currents.

Because of the switching nature of DC/DC converters, the input of these converters must be driven from a source with both low AC impedance and adequate DC input regulation. Performance will degrade with increasing input inductance. Excessive input inductance may inhibit operation. The DC input regulation specifies that the input voltage, once operating, must never degrade below the Shut-Down Threshold under all load conditions. Be sure to use adequate trace sizes and mount components close to the converter.

**I/O Filtering, Input Ripple Current and Output Noise**

All models in this converter series are tested and specified for input reflected ripple current and output noise using designated external input/output components, circuits and layout as shown in the figures below. External input capacitors (CIN in the figure) serve primarily as energy storage elements, minimizing line voltage variations caused by transient IR drops in the input conductors. Users should select input capacitors for bulk capacitance (at appropriate frequencies), low ESR and high RMS ripple current ratings. In the figure below,

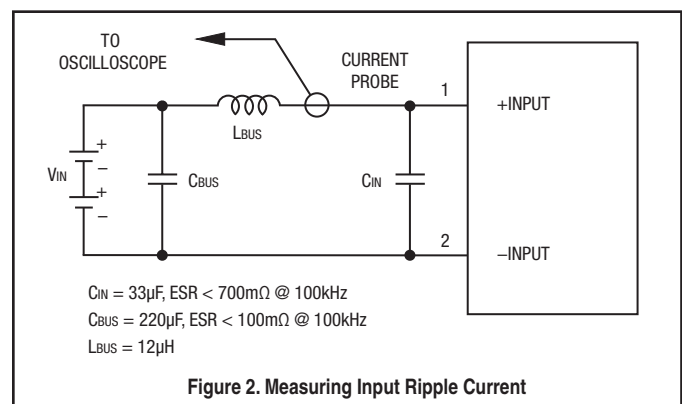

the C<sub>BUS</sub> and L<sub>BUS</sub> components simulate a typical DC voltage bus. Your specific system configuration may require additional considerations. Please note that the values of C<sub>IN</sub>, L<sub>BUS</sub> and C<sub>BUS</sub> will vary according to the specific converter model.

In critical applications, output ripple and noise (also referred to as periodic and random deviations or PARD) may be reduced by adding filter elements such as multiple external capacitors. Be sure to calculate component temperature rise from reflected AC current dissipated inside capacitor ESR. Our Application Engineers can recommend potential solutions.

In the figure, the two copper strips simulate real-world printed circuit impedances between the power supply and its load. In order to minimize circuit errors and standardize tests between units, scope measurements should be made using BNC connectors or the probe ground should not exceed one half inch and soldered directly to the fixture.

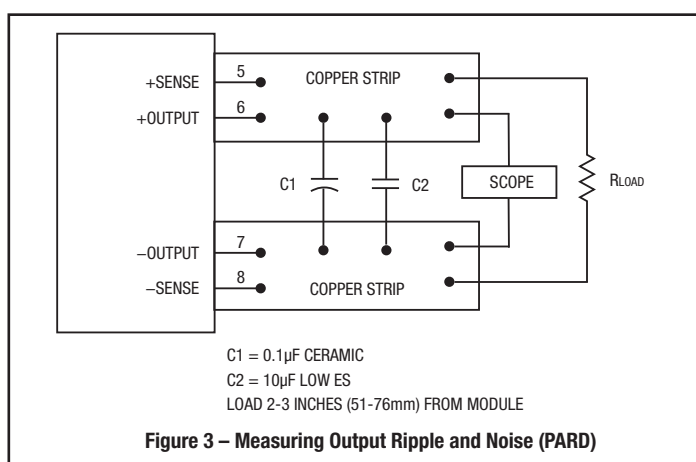

**Figure 3 – Measuring Output Ripple and Noise (PARD)**

**Floating Outputs**

Since these are isolated DC/DC converters, their outputs are “floating” with respect to their input. The essential feature of such isolation is ideal ZERO CURRENT FLOW between input and output. Real-world converters however do exhibit tiny leakage currents between input and output (see Specifications). These leakages consist of both an AC stray capacitance coupling component and a DC leakage resistance. When using the isolation feature, do not allow the isolation voltage to exceed specifications. Otherwise the converter may be damaged. Designers will normally use the negative output (-Output) as the ground return of the load circuit. You can however use the positive output (+Output) as the ground return to effectively reverse the output polarity.

**Minimum Output Loading Requirements**

These converters employ a synchronous rectifier design topology. All models regulate within specification and are stable under no load to full load conditions. Operation under no load might however slightly increase output ripple and noise.

**Thermal Shutdown**

To prevent many over temperature problems and damage, these converters include thermal shutdown circuitry. If environmental conditions cause the temperature of the DC/DC’s to rise above the Operating Temperature Range up to the shutdown temperature, an on-board electronic temperature sensor will power down the unit. When the temperature decreases below the turn-on threshold, the converter will automatically restart. There is a small amount of hysteresis to prevent rapid on/off cycling.

**CAUTION:** If you operate too close to the thermal limits, the converter may shut down suddenly without warning. Be sure to thoroughly test your application to avoid unplanned thermal shutdown.

**Temperature Derating Curves**

The graphs in the next section illustrate typical operation under a variety of conditions. The Derating curves show the maximum continuous ambient air temperature and decreasing maximum output current which is acceptable under increasing forced airflow measured in Linear Feet per Minute (“LFM”). Note that these are AVERAGE measurements. The converter will accept brief increases in temperature and/or current or reduced airflow as long as the average is not exceeded.

Note that the temperatures are of the ambient airflow, not the converter itself which is obviously running at higher temperature than the outside air. Also note that “natural convection” is defined as very low flow rates which are not using fan-forced airflow. Depending on the application, “natural convection” is usually about 30-65 LFM but is not equal to still air (0 LFM).

MPS makes Characterization measurements in a closed cycle wind tunnel with calibrated airflow. We use both thermocouples and an infrared camera system to observe thermal performance. As a practical matter, it is quite difficult to insert an anemometer to precisely measure airflow in most applications. Sometimes it is possible to estimate the effective airflow if you thoroughly understand the enclosure geometry, entry/exit orifice areas and the fan flowrate specifications. If in doubt, contact MPS to discuss placement and measurement techniques of suggested temperature sensors.

**CAUTION:** If you routinely or accidentally exceed these Derating guidelines, the converter may have an unplanned Over Temperature shut down. Also, these graphs are all collected at slightly above Sea Level altitude. Be sure to reduce the derating for higher density altitude.

**Output Overvoltage Protection**

This converter monitors its output voltage for an over-voltage condition using an on-board electronic comparator. The signal is optically coupled to the primary side PWM controller. If the output exceeds OVP limits, the sensing circuit will power down the unit, and the output voltage will decrease. After a time-out period, the PWM will automatically attempt to restart, causing the output voltage to ramp up to its rated value. It is not necessary to power down and reset the converter for the this automatic OVP-recovery restart.

If the fault condition persists and the output voltage climbs to excessive levels, the OVP circuitry will initiate another shutdown cycle. This on/off cycling is referred to as “hiccup” mode. It safely tests full current rated output voltage without damaging the converter.

**Output Fusing**

The converter is extensively protected against current, voltage and temperature extremes. However your output application circuit may need additional protection. In the extremely unlikely event of output circuit failure, excessive voltage could be applied to your circuit. Consider using an appropriate fuse in series with the output.

**Output Current Limiting**

As soon as the output current increases to approximately 125% to 150% of its maximum rated value, the DC/DC converter will enter a current-limiting mode. The output voltage will decrease proportionally with increases in output

current, thereby maintaining a somewhat constant power output. This is commonly referred to as power limiting.

Current limiting inception is defined as the point at which full power falls below the rated tolerance. See the Performance/Functional Specifications. Note particularly that the output current may briefly rise above its rated value. This enhances reliability and continued operation of your application. If the output current is too high, the converter will enter the short circuit condition.

**Output Short Circuit Condition**

When a converter is in current-limit mode, the output voltage will drop as the output current demand increases. If the output voltage drops too low, the magnetically coupled voltage used to develop primary side voltages will also drop, thereby shutting down the PWM controller. Following a time-out period, the PWM will restart, causing the output voltage to begin ramping up to its appropriate value. If the short-circuit condition persists, another shutdown cycle will initiate. This on/off cycling is called "hiccup mode". The hiccup cycling reduces the average output current, thereby preventing excessive internal temperatures. A short circuit can be tolerated indefinitely.

**Remote Sense Input**

Sense inputs compensate for output voltage inaccuracy delivered at the load. This is done by correcting voltage drops along the output wiring such as moderate IR drops and the current carrying capacity of PC board etc. Sense inputs also improve the stability of the converter and load system by optimizing the control loop phase margin.

Note: The Sense input and power Vout lines are internally connected through low value resistors to their respective polarities so that the converter can operate without external connection to the Sense. Nevertheless, if the Sense function is not used for remote regulation, the user should connect +Sense to +Vout and -Sense to -Vout at the converter pins.

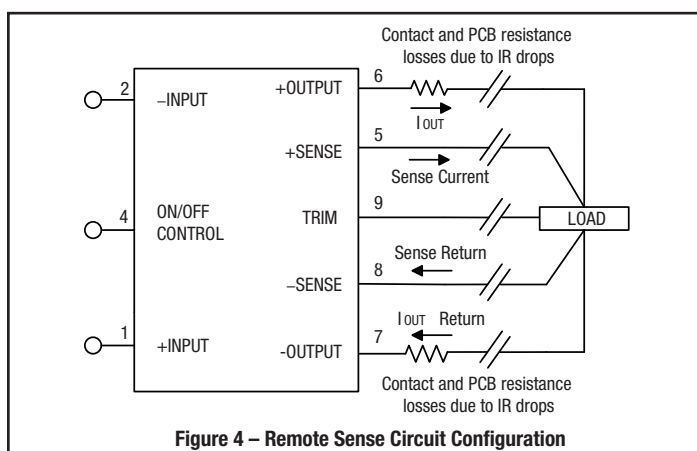

**Figure 4 – Remote Sense Circuit Configuration**

The remote Sense lines carry very little current. They are also capacitively coupled to the output lines and therefore are in the feedback control loop to regulate and stabilize the output. As such, they are not low impedance inputs and must be treated with care in PC board layouts. Sense lines on the PCB should run adjacent to DC signals, preferably Ground. In cables and discrete wiring, use twisted pair, shielded tubing or similar techniques.

Please observe Sense inputs tolerance to avoid improper operation:

$$[V_{out(+)} - V_{out(-)}] - [Sense(+) - Sense(-)] \leq 10\% \text{ of } V_{out}$$

Output overvoltage protection is monitored at the output voltage pin, not the Sense pin. Therefore excessive voltage differences between Vout and Sense together with trim adjustment of the output can cause the overvoltage protection circuit to activate and shut down the output.

Power derating of the converter is based on the combination of maximum output current and the highest output voltage. Therefore the designer must insure:

$$(V_{out \text{ at pins}}) \times (I_{out}) \leq (\text{Max. rated output power})$$

**Trimming the Output Voltage**

The Trim input to the converter allows the user to adjust the output voltage over the rated trim range (please refer to the Specifications). In the trim equations and circuit diagrams that follow, trim adjustments use either a trimpot or a single fixed resistor connected between the Trim input and either the +Sense or -Sense terminals. (On some converters, an external user-supplied precision DC voltage may also be used for trimming). Trimming resistors should have a low temperature coefficient ( $\pm 100$  ppm/deg.C or less) and be mounted close to the converter. Keep leads short. If the trim function is not used, leave the trim unconnected. With no trim, the converter will exhibit its specified output voltage accuracy.

There are two CAUTION's to be aware for the Trim input:

CAUTION: To avoid unplanned power down cycles, do not exceed EITHER the maximum output voltage OR the maximum output power when setting the trim. Be particularly careful with a trimpot. If the output voltage is excessive, the

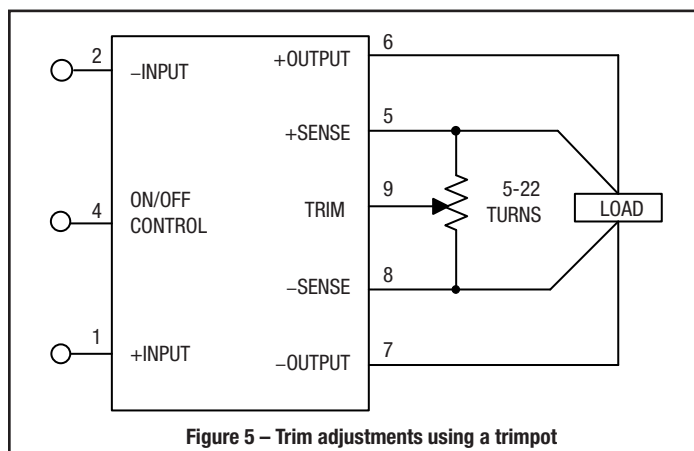

**Figure 5 – Trim adjustments using a trimpot**

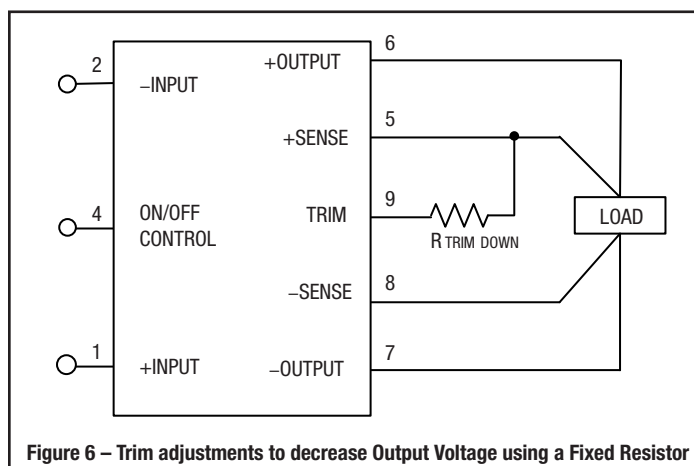

**Figure 6 – Trim adjustments to decrease Output Voltage using a Fixed Resistor**



OVP circuit may inadvertently shut down the converter. If the maximum power is exceeded, the converter may enter current limiting. If the power is exceeded for an extended period, the converter may overheat and encounter overtemperature shut down.

**CAUTION:** Be careful of external electrical noise. The Trim input is a sensitive input to the converter's feedback control loop. Excessive electrical noise may cause instability or oscillation. Keep external connections short to the Trim input. Use shielding if needed.

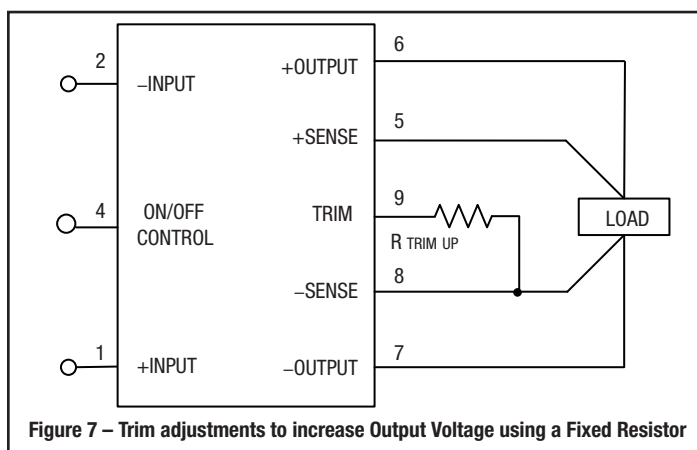

Figure 7 – Trim adjustments to increase Output Voltage using a Fixed Resistor

**Trim Equations**

**Trim Up**

<Connect trim resistor between Trim and -Sense>

**Trim Down**

<Connect trim resistor between Trim and +Sense>

UEI-3.3/15-Q12, -3.3/18-Q48	
$R_{T_{UP}} (\Omega) = \frac{12775}{V_O - 3.3} - 2050$	$R_{T_{DOWN}} (\Omega) = \frac{5110 (V_O - 2.5)}{3.3 - V_O} - 2050$
UEI-5/10-Q12, -5/12-Q48	
$R_{T_{UP}} (\Omega) = \frac{12775}{V_O - 5} - 2050$	$R_{T_{DOWN}} (\Omega) = \frac{5110 (V_O - 2.5)}{5 - V_O} - 2050$
UEI-12/4.2-Q12, -12/5-Q48	
$R_{T_{UP}} (\Omega) = \frac{25000}{V_O - 12} - 5110$	$R_{T_{DOWN}} (\Omega) = \frac{10000 (V_O - 2.5)}{12 - V_O} - 5110$
UEI-15/3.3-Q12, UEI-15/4-Q48	
$R_{T_{UP}} (\Omega) = \frac{25000}{V_O - 15} - 5110$	$R_{T_{DOWN}} (\Omega) = \frac{10000 (V_O - 2.5)}{15 - V_O} - 5110$

Where  $V_o$  = Desired output voltage. Adjustment accuracy is subject to resistor tolerances and factory-adjusted output accuracy. Mount trim resistor close to converter. Use short leads.

**Remote On/Off Control**

On the input side, a remote On/Off Control can be ordered with either polarity.

**Positive:** Standard models are enabled when the On/Off pin is left open or is pulled high to +15V with respect to  $-V_{IN}$ . An internal bias current causes the open pin to rise to +15V. Some models will also turn on at lower intermediate voltages (see Specifications). Positive-polarity devices are disabled when the On/Off is grounded or brought to within a low voltage (see Specifications) with respect to  $-V_{IN}$ .

**Negative:** Optional negative-polarity devices are on (enabled) when the On/Off is grounded or brought to within a low voltage (see Specifications) with respect to  $-V_{IN}$ . The device is off (disabled) when the On/Off is left open or is pulled high to +15Vdc Max. with respect to  $-V_{IN}$ .

Dynamic control of the On/Off function should be able to sink appropriate signal current when brought low and withstand appropriate voltage when brought high. Be aware too that there is a finite time in milliseconds (see Specifications) between the time of On/Off Control activation and stable, regulated output. This time will vary slightly with output load type and current and input conditions.

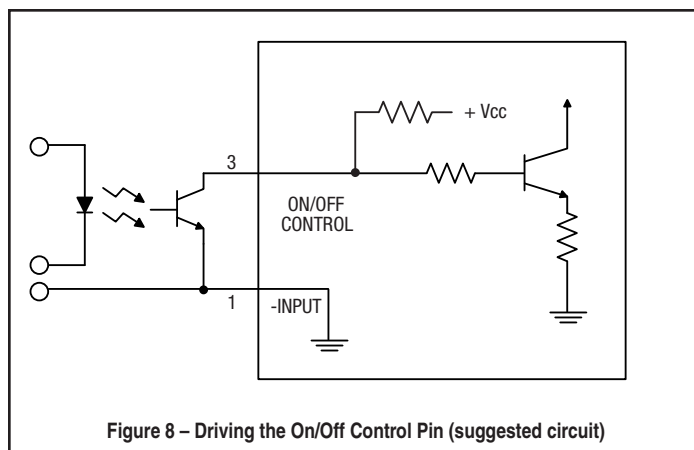

Figure 8 – Driving the On/Off Control Pin (suggested circuit)

There are two CAUTIONS for the On/Off Control:

**CAUTION:** While it is possible to control the On/Off with external logic if you carefully observe the voltage levels, the preferred circuit is either an open drain/open collector transistor or a relay (which can thereupon be controlled by logic).

**CAUTION:** Do not apply voltages to the On/Off pin when there is no input power voltage. Otherwise the converter may be permanently damaged.

**Typical Performance Curves**

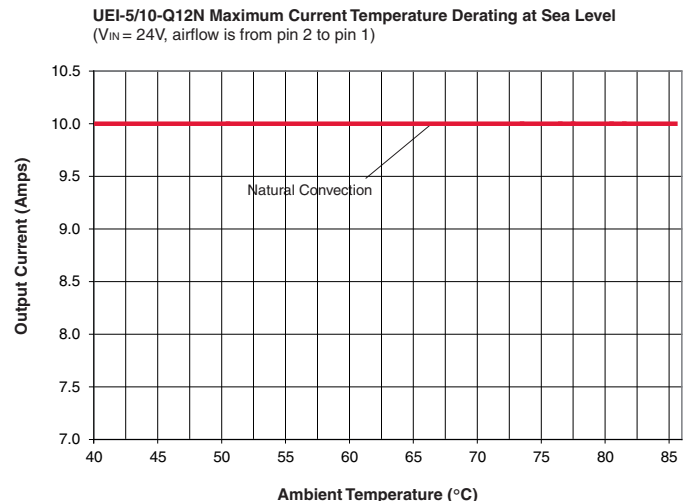
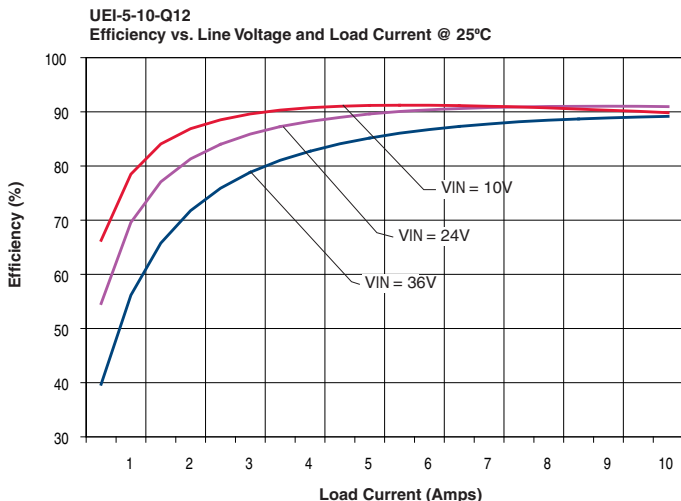
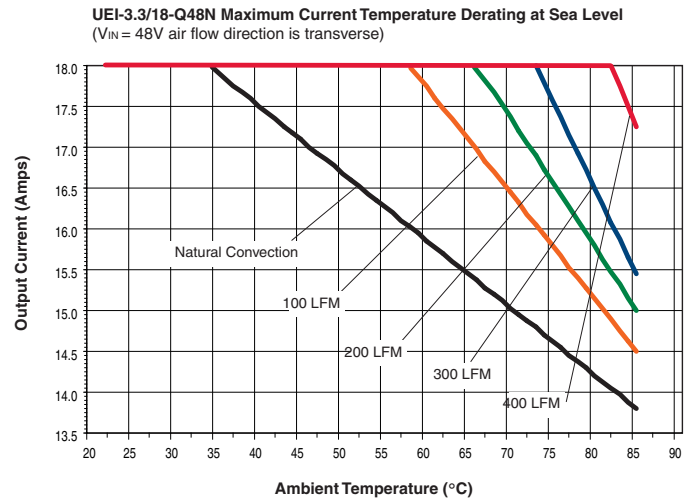
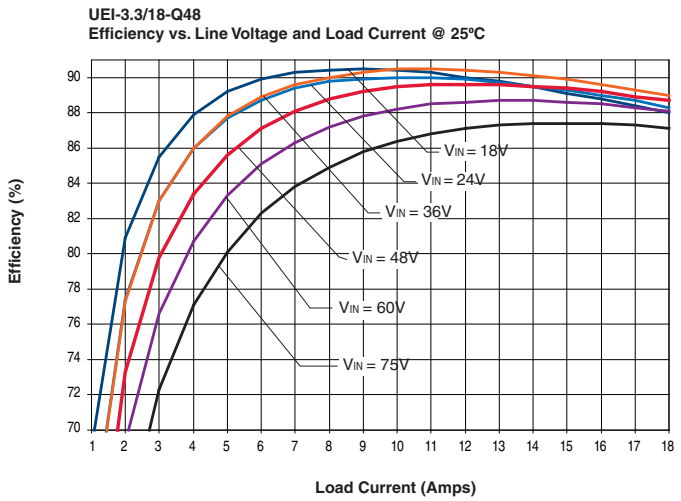
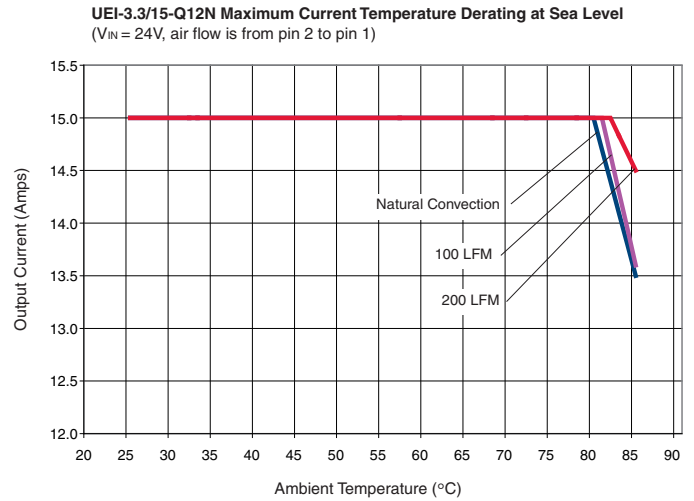
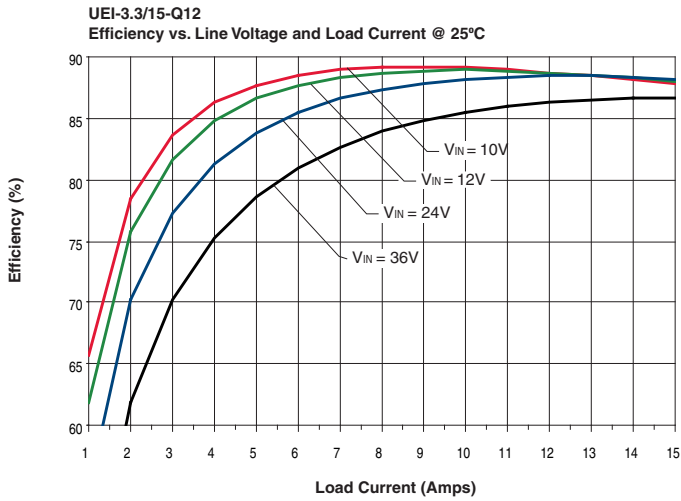

**Typical Performance Curves**

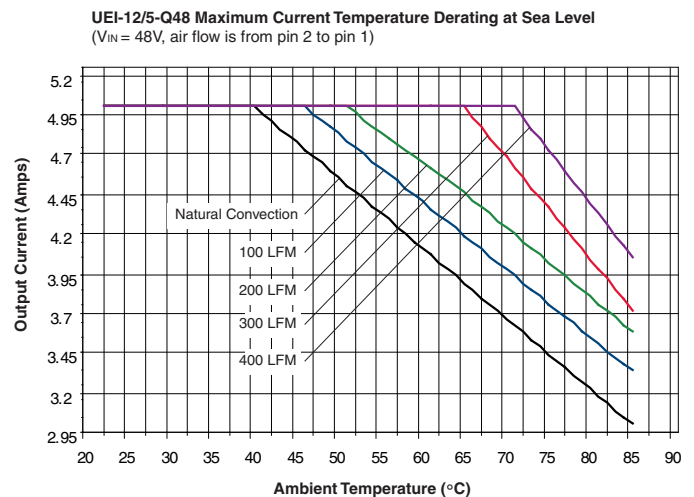
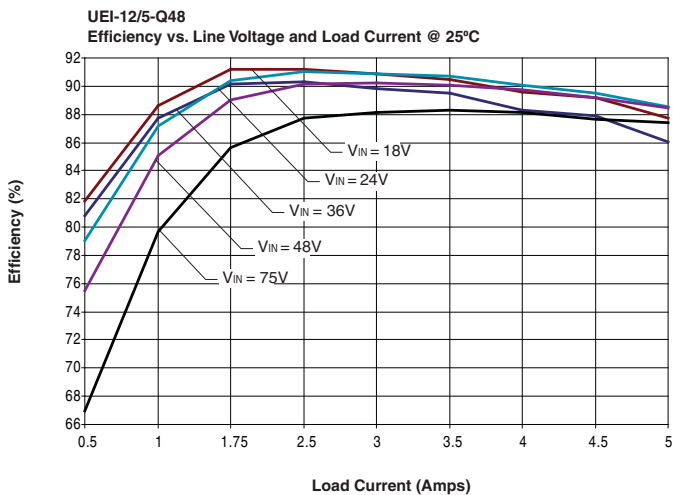
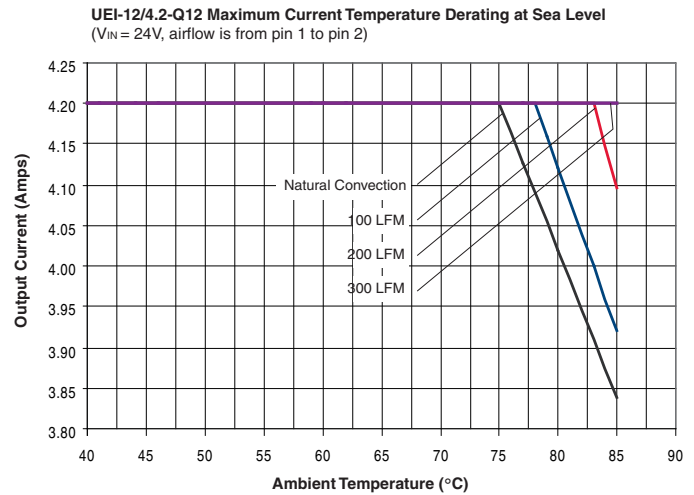
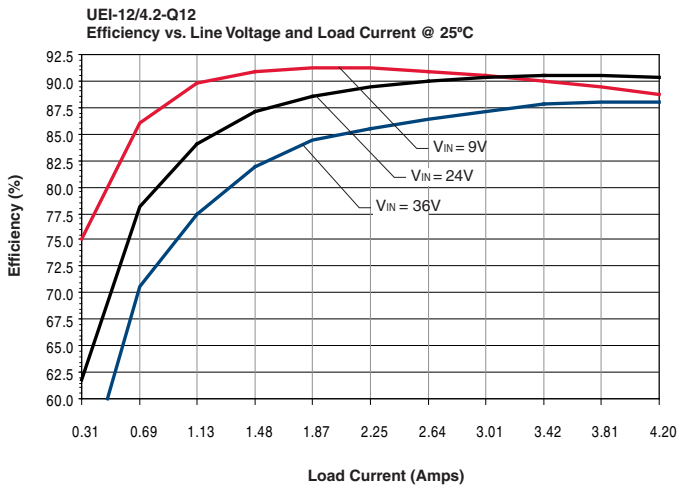
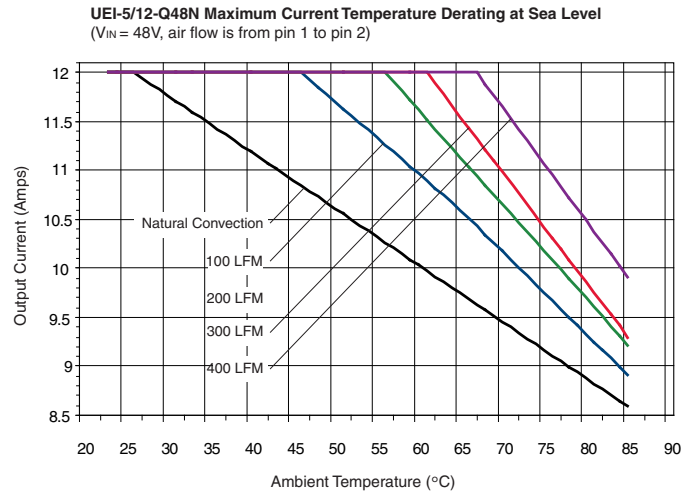
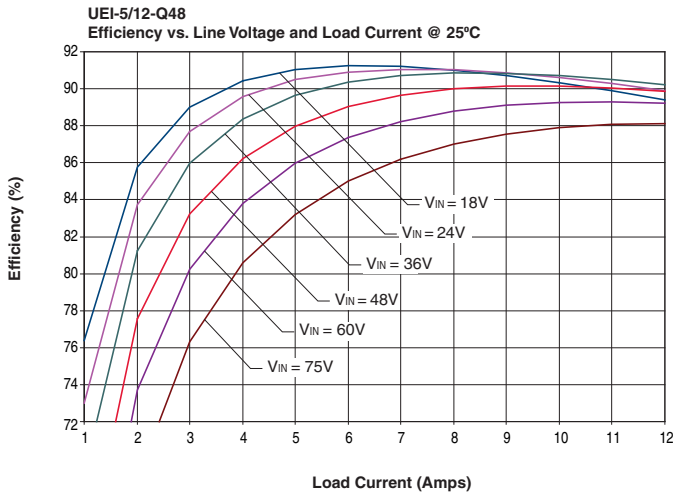

**Typical Performance Curves**

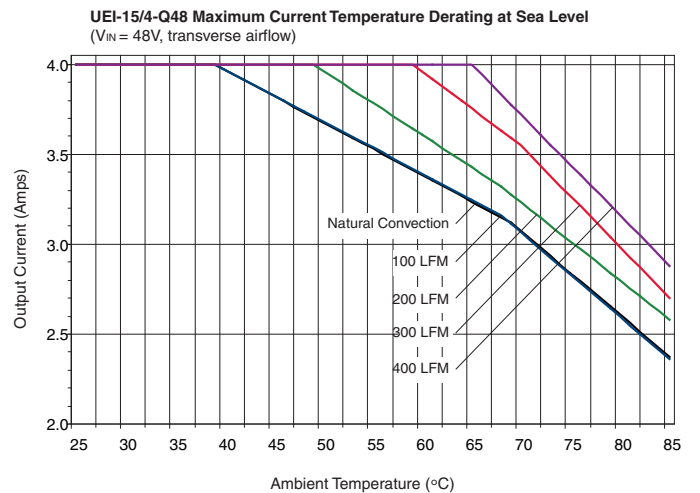
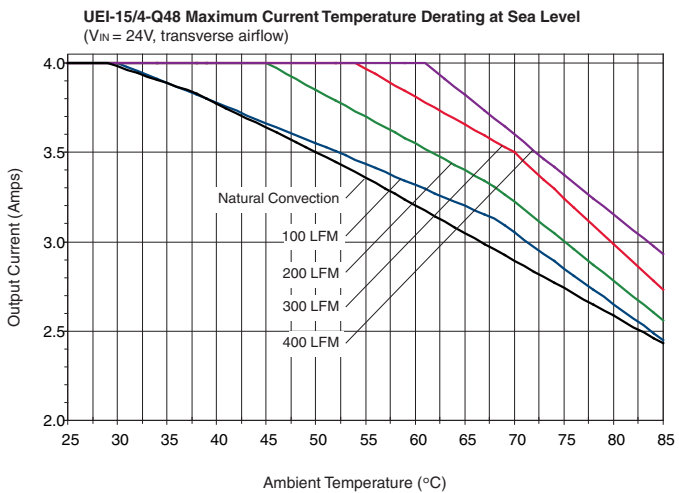
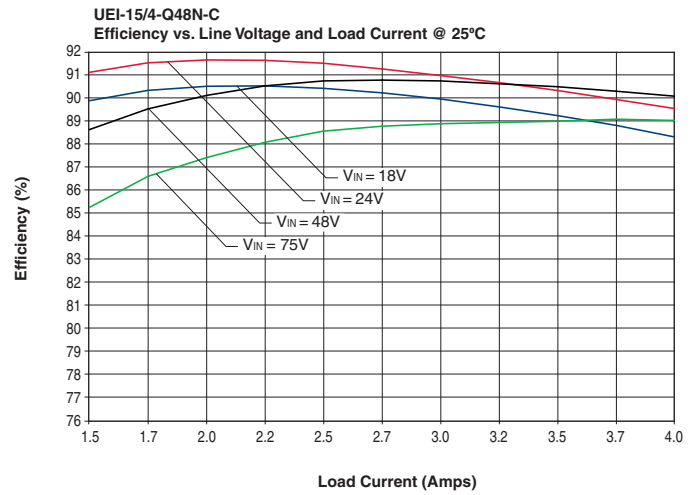
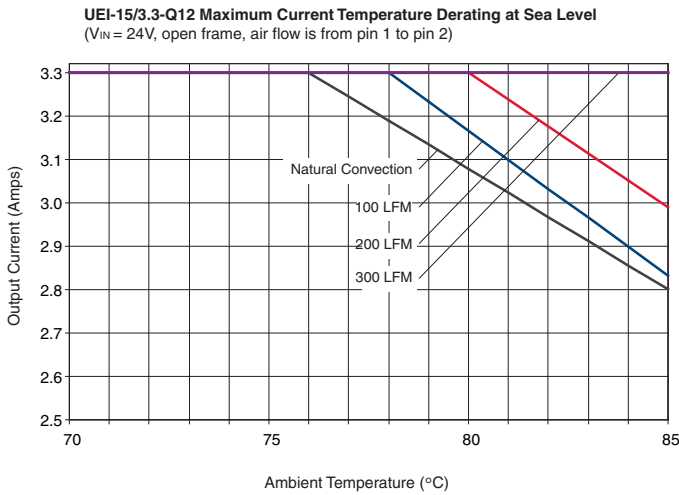
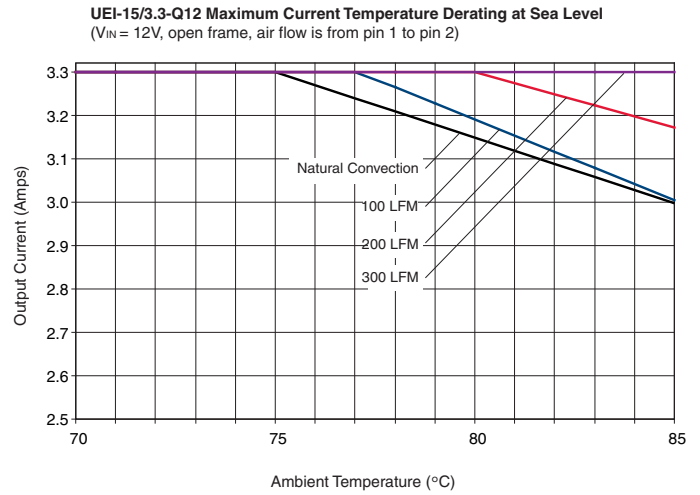
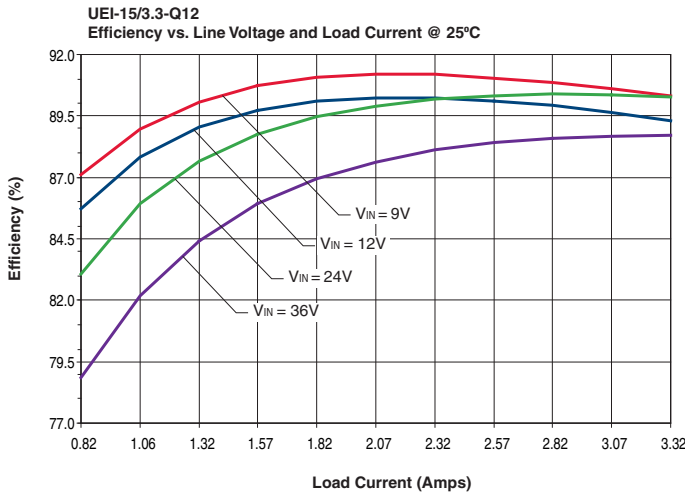

Murata Power Solutions, Inc.  
11 Cabot Boulevard, Mansfield, MA 02048-1151 U.S.A.  
ISO 9001 and 14001 REGISTERED

Murata Power Solutions, Inc. makes no representation that the use of its products in the circuits described herein, or the use of other technical information contained herein, will not infringe upon existing or future patent rights. The descriptions contained herein do not imply the granting of licenses to make, use, or sell equipment constructed in accordance therewith. Specifications are subject to change without notice.  
© 2010 Murata Power Solutions, Inc.