

Datasheet

4.25 Gbps Fibre Channel SFP Transceiver

SFPFC401



Features

- Designed for SFF-8472 compliance (SFP)
- 1.06 Gbps, 2.125 Gbps, and 4.25 Gbps Fibre Channel support
- Single-mode optics (Simplex LC)
- Dual fiber, bi-directional
- Class 1 laser: 1310 nm
- 10 km reach
- Digital Diagnostics (SFF-8724)

General Operations

Parameter	Symbol	Min.	Max.	Unit
Supply Voltage	V_{cc}	3.135	3.465	V
Total Current	I_{cc}	-	300	mA
Power Supply Noise Rejection ^a	PSR	100	-	mV _{p-p}
Operating Temperature of SFP Case ^b	T_{op}	-5	70	°C
Storage Temperature	T_{st}	-40	85	°C
Data Rate FC-400 Fibre Channel	DR	-	4250	Mbps

a) 20 Hz to 155 MHz

b) Maximum Relative Humidity is 85%, non-condensing

Transmitter Specifications (Optical)

Parameter	Symbol	Min	Max	Unit
Optical Power	P_{op}	-8.4	-1	dBm
Average Launch Power Of Off Tx	P_{off}	-	-30	dBm
Eye Mask	Fibre Channel ^c Compliant			
Optical Rise Time ^d	t_r	-	130	ps
Optical Fall Time ^d	t_f	-	130	ps
Mean Tx Wavelength: 1310	λ	1260	1360	nm
Spectral Width (20 dB)	$\Delta\lambda_{20}$	-	1	nm
Dispersion Penalty (10 km) ^e	dp	-	1	dB
Relative Intensity Noise	RIN	-	-120	dB/Hz
Reflection Tolerance ^f	rp	-24	-	dB

c) FC400 compliant

d) 20% - 80% values

 e) Measured at BER of $1e^{-12}$, PRBS of 2^7-1 , at eye center

f) 1 dB degradation of receiver sensitivity

Datasheet

Transmitter Specifications (Electrical)

Parameter	Symbol	Min	Max	Unit
Input Differential Impedance	R_{in}	80	120	Ω
PECL Single Ended Data Input Swing	$V_{in,p-p}$	250	1200	mV
TxFault_Fault	V_{fault}	2	V_{cc}	V
TxFault_Normal	V_{normal}	V_{ee}	$V_{ee}+0.5$	V
TxDisable_Disable	V_d	2	V_{cc}	V
TxDisable_Enable	V_{en}	V_{ee}	$V_{ee}+0.8$	V

Receiver Specifications (Optical)

Parameter	Symbol	Min	Max	Unit
Receive Power ^{g)}	$R_{sens,low/high}$	-18	0	dBm
Damage Threshold for Receiver	$P_{in,damage}$	4	-	dBm
Mean Rx Wavelength: 1310	λ	1260	1360	nm
Maximum Reflectance of Receiver	RX_r	-	-27	dB
LOS Assert	-	-30	-	dBm
LOS De-assert	-	-	-20	dBm
LOS Hysteresis	-	0.5	-	dB

g) at 4.25 Gbps, $1e^{-12}$ BER, PRBS 2⁷-1

Receiver Specifications (Electrical)

Parameter	Symbol	Min	Max	Unit
PECL Single Ended Data Output Swing	$V_{out,p-p}$	185	800	mV
Data Output Rise Time	t_r	-	175	ps
Data Output Fall Time	t_f	-	175	ps

Timing and Electrical

Parameter	Symbol	Min	Max	Unit
Tx Disable Negate Time	t_{on}	-	1	μs
Tx Disable Assert Time	t_{off}	-	10	μs
Time To Initialize, Including Reset of Tx Fault	t_{init}	-	300	ms
Tx Fault Assert Time	t_{fault}	-	100	μs
Tx Disable To Reset	t_{reset}	10	-	μs
LOS Assert Time	$t_{loss_{on}}$	-	100	μs
LOS De-assert Time	$t_{loss_{off}}$	-	100	μs
Serial ID Clock Rate	f_{serial_clock}	2	100	KHz
RX_LOS Voltage (High)	-	2	V_{cc}	V
RX_LOS Voltage (Low)	-	-	0.8	V
LOS Output Voltage-Fault	$V_{LOS\ fault}$	2	V_{cc}	V
LOS Output Voltage-Normal	$V_{LOS\ normal}$	V_{ee}	$V_{ee}+0.5$	V
MOD_DEF (0:2)-High	V_H	2	V_{cc}	V
MOD_DEF (0:2)-Low	V_L	V_{ee}	$V_{ee}+0.5$	V

Datasheet

Digital Diagnostics

Parameter	Range	Accuracy	Unit	Calibration	Bit Value	Formula
Temperature	-5 to 70	± 3	° C	Internal	1/256 C	$T_c(C) = T_{ad}(16 \text{ bit signed twos complement})/256$
Voltage	0 to V_{cc}	0.1	V	Internal	100µV	$V(\text{Volts}) = V_{ad}(16 \text{ bit unsigned integer}) * 0.1$
Bias Current	0 to 120	5	mA	External	-	$I(\text{mA}) = I_{slope} * I_{ad}(16 \text{ bit unsigned integer}) + I_{offset}$
TX Power	-14 to -8	±3 dB	dBm	External	-	$TX_PWR(\mu W) = TX_PWR_{slope} * TX_PWR_{ad}(16 \text{ bit unsigned integer}) + TX_PWR_{offset}$
RX Power	-28.2 to -8	±3 dB	dBm	External	-	$RX_PWR(\mu W) = A_0 + A_1 * x + A_2 * x^2 + A_3 * x^3 + A_4 * x^4$

Pin	Function	Notes
1	V_{eeT}	TX GND
2	TX_FAULT	Open Collector
3	TX_DISABLE	Internally Pulled High
4	MOD_DEF2	Serial Data Input
5	MOD_DEF1	Serial Clock Input
6	MOD_DEF0	Internally Grounded
7	NC	Not Connected
8	LOS	Open Collector
9	V_{eeR}	RX Ground
10	V_{eeR}	RX Ground
11	V_{eeR}	RX Ground
12	RXD-	RX Data Negative
13	RXD+	RX Data Positive
14	V_{eeR}	RX GND
15	V_{ccR}	RX Power
16	V_{ccT}	TX Power
17	V_{eeT}	TX GND
18	TXD+	TX Data Positive
19	TXD-	TX Data Negative
20	V_{eeT}	TX GND

Ordering Information

Model	Description	Data Rate (Mbps)	Wavelength (nm)		Connector Type	Bail Latch Color	Distance Range (km)
			Tx	Rx			
SFPFC401	1/2/4 Gbps Fibre Channel and 1 Gigabit Ethernet SFP Transceiver.	1063 2125 4250	1310	1310	LC	Yellow	0 - 10

Datasheet

Outline Drawing

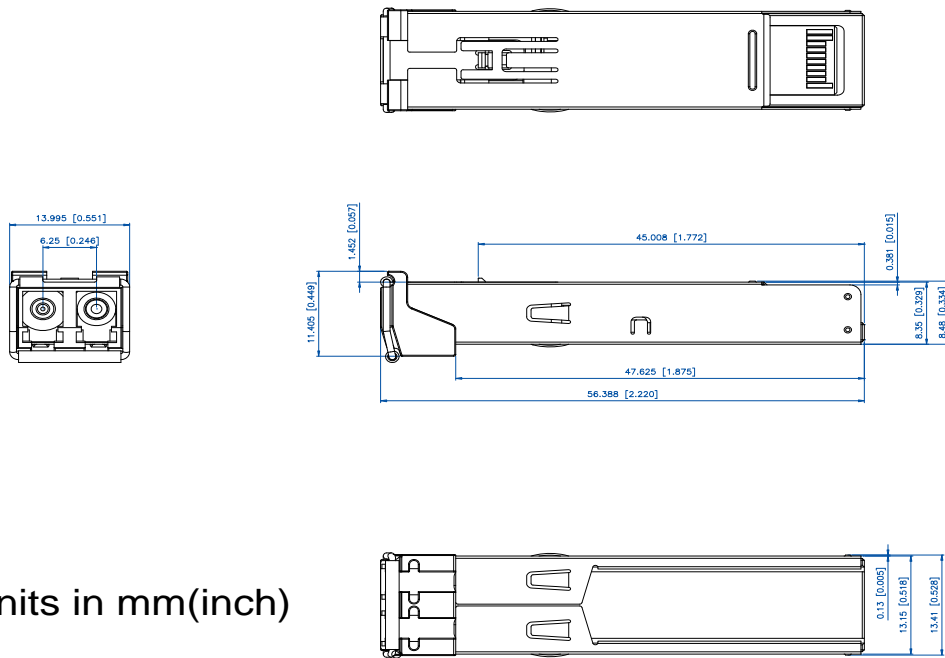

Units in mm(inch)

Regulatory Compliances

RoHS directive; China RoHS; California RoHS Law, USA and Canada UL listing; 21CFR 1040.10 and 1040.11; SFP MSA SFF-8074i; SFF-8472; Telecordia GR-468

Warnings

Handling Precautions: This device is susceptible to damage as a result of electrostatic discharge (ESD). A static free environment is highly recommended. Follow guidelines according to proper ESD procedures.

Laser Safety: Radiation emitted by laser devices can be dangerous to human eyes. Avoid eye exposure to direct or indirect radiation.

MRV has more than 50 offices throughout the world. Addresses, phone numbers and fax numbers are listed at www.mrv.com. Please e-mail us at sales@mrv.com or call us for assistance.

MRV Los Angeles
20415 Nordhoff St.
Chatsworth, CA 91311
800-338-5316
818-773-0900

MRV Boston
295 Foster St.
Littleton, MA 01460
800-338-5316
978-952-4700

MRV International
Business Park Moerfelden
Waldeckerstrasse 13
64546 Moerfelden-Walldorf
Germany
Tel. (49) 6105/2070
Fax (49) 6105/207-100

All statements, technical information and recommendations related to the products herein are based upon information believed to be reliable or accurate. However, the accuracy or completeness thereof is not guaranteed, and no responsibility is assumed for any inaccuracies. Please contact MRV Communications for more information. MRV Communications and the MRV Communications logo are trademarks of MRV Communications, Inc. Other trademarks are the property of their respective holders.