

1 13/16" (46 mm) Three Turn Wirewound Upper Grade Precision Potentiometer

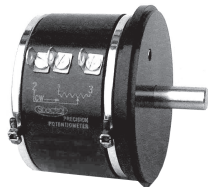

FEATURES

- Large range of ohmic values: 15 Ω to 50 k Ω
- Bushing mount, servo mount and screw mount version
- Gangable up to 3 sections
- Extra taps available upon request

ELECTRICAL SPECIFICATIONS		
PARAMETER		
Total Resistance Tolerance: 100 Ω and Above Below 100 Ω	STANDARD 15 Ω to 50 k Ω $\pm 3\%$ $\pm 5\%$	SPECIAL 150 k Ω $\pm 1\%$ $\pm 3\%$
Linearity (Independent) 15 Ω to 1 k Ω 1 k Ω to 5 k Ω 5 k Ω to 25 k Ω 25 k Ω and Above	STANDARD $\pm 0.25\%$ $\pm 0.25\%$ $\pm 0.25\%$ $\pm 0.25\%$	SPECIAL $\pm 0.15\%$ $\pm 0.10\%$ $\pm 0.075\%$ $\pm 0.05\%$
Noise	100 Ω ENR	
Electrical Rotation	1080° + 4° - 0°	
Power Rating Section 1 Additional Sections	2.0 W at 70 °C ambient, derated to zero at 125 °C 75 % of the rating of section 1 (1.5 W at 70 °C)	
Insulation Resistance	1000 M Ω minimum, 500 V _{DC}	
Dielectric Strength	1000 V _{RMS} , 60 Hz	
Absolute Minimum, Resistance	Linearity x total resistance or 0.5 Ω , whichever is greater	
End Voltage	Linearity x total applied voltage for total resistance above 20 Ω , 2.0 % of total applied voltage for 20 Ω and below	
Phasing (CCW End Points)	Additional sections phased to section 1 within $\pm 1^\circ$	
Taps (Extra)	Available as special, standard tolerance $\pm 1^\circ$	

ORDERING INFORMATION/DESCRIPTION				
The Model 852 can be ordered from this data sheet with a variety of alternate characteristics, as shown above. For most rapid service on your order, please state:				
852	C	1	50K	BO1
MODEL	MOUNTING	NUMBER OF SECTIONS	RESISTANCE OF EACH SECTION	PACKAGING
	B: Bushing S: Servo C: Screw	From 1 up to 3 max.	Beginning with the section nearest the mounting end	Box of 1 piece

SAP PART NUMBERING GUIDELINES				
852	C	1	503	B01
MODEL	STYLE	NUMBER OF SECTIONS	OHMIC VALUE SECTION N° 1	PACKAGING



DIMENSIONS in inches (millimeters)

SERVO MOUNT

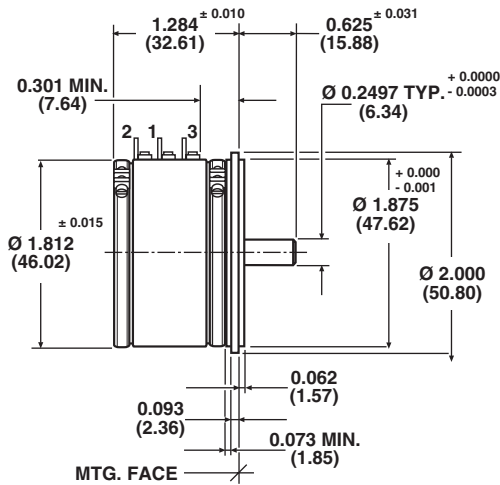

BUSHING MOUNT

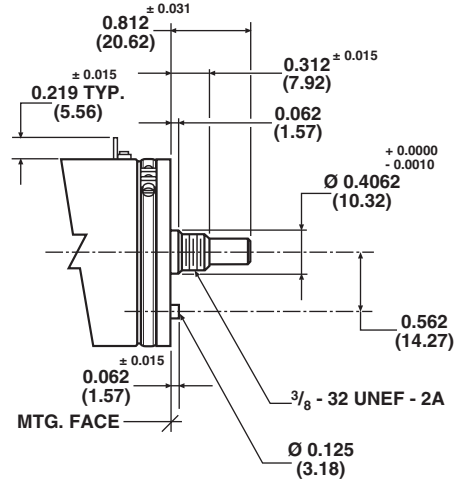

SCREW MOUNT

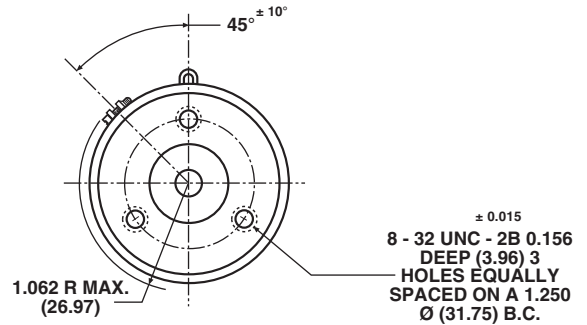
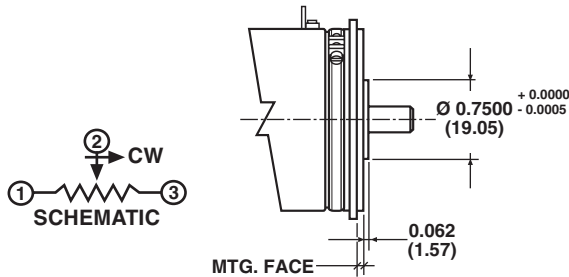

TOLERANCES: UNLESS OTHERWISE NOTED.
DECIMALS ± 0.005 ANGLES ± 2°

1 ADD 0.992 ± 0.010 (25.20) FOR EACH
ADDITIONAL SECTION

MECHANICAL SPECIFICATIONS			
PARAMETER			
Rotation	1080° + 10° - 0°		
Bearing Type	SERVO Ball bearing	SCREW Ball bearing	BUSHING Sleeve bearing
Torque (Maximums) Servo or Screw Section 1 Bushing Section 1 Each Additional Section	STARTING 1.20 oz. - in (86.4 g - cm) 1.75 oz. - in (126.0 g - cm) 0.80 oz. - in (57.6 g - cm)		RUNNING 0.80 oz. - in (57.6 g - cm) 1.25 oz. - in (90.0 g - cm) 0.60 oz. - in (43.2 g - cm)
Mechanical Runouts (Maximums): Shaft Runout (TIR/in) Pilot Dia. Runout (TIR) Lateral Runout (TIR) Shaft End Play Shaft Radial Play	SERVO/SCREW 0.002" (0.05 cm) 0.002" (0.05 cm) 0.003" (0.08 cm) 0.005" (0.13 cm) 0.002" (0.05 cm)		BUSHING 0.002" (0.05 cm) 0.002" (0.05 cm) 0.005" (0.13 cm) 0.005" (0.13 cm) 0.003" (0.08 cm)
Weight (Maximums) Single Section Each Additional Section Stop Strength	3.5 oz. (99.2 g) 2.7 oz. (76.5 g) 1000 oz. - in, static (72 kg - cm)		
Ganging	3 sections maximum, terminal alignment, added sections within ± 10° of section 1 terminals		
Moment of Inertia	5.5 g - cm ² per section maximum		

Model 852



Vishay Spectrol

1 13/16" (46 mm) Three Turn Wirewound
Upper Grade Precision Potentiometer

MATERIAL SPECIFICATIONS	
Housing	Glass filled, thermoset plastic
Lids	Aluminum, anodized
Shaft	Stainless steel, non-magnetic non-passivated
Terminals	Brass, plated for solderability
Clamp Ring	Stainless steel
Bushing Mount Hardware Lockwasher Internal Tooth: Panel Nut:	Steel, nickel plated Brass nickel plated

MARKING	
Unit Identification	Units shall be marked with Spectrol name and model No, resistance and resistance tolerance, linearity, terminal identification and date code

ENVIRONMENTAL SPECIFICATIONS	
Vibration	15 g thru 2000 CPS
Shock	50 g
Salt Spray	96 h
Rotational Life	600 000 shaft revolutions
Load Life	900 h
Operating Temperature Range	- 55 °C to + 125 °C

POWER RATING CHART

(Ratings for cup N° 1.
Additional cups 75 % of values shown)

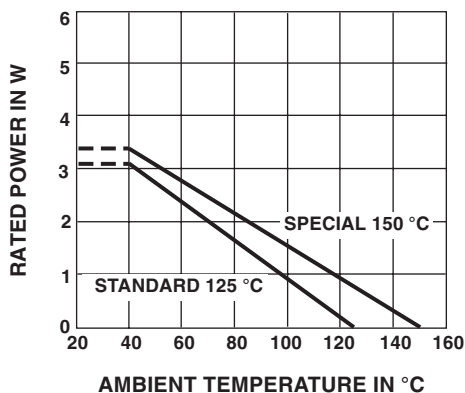

RESISTANCE ELEMENT DATA					
STANDARD RESISTANCE VALUES (Ω)	RESOLUTION (%)	OHMS PER TURN	MAXIMUM CURRENT AT 70 °C AMBIENT (mA)	MAXIMUM VOLTAGE ACROSS COIL (V)	WIRE TEMP. COEF. (ppm/°C)
20	0.094	0.019	316	6.33	800
50	0.074	0.037	200	10.0	800
100	0.071	0.071	141	14.2	180
200	0.072	0.145	100	20.0	20
500	0.064	0.320	63.2	31.6	20
1K	0.050	0.500	44.7	44.7	20
2K	0.047	0.948	31.6	63.3	20
5K	0.035	1.733	20.0	100	20
10K	0.029	2.923	14.1	142	20
20K	0.024	4.797	10.0	200	20
50K	0.017	8.313	6.32	316	20
100K	0.015	14.535	4.47	447	20
150K	0.013	19.987	3.65	548	20



Disclaimer

All product specifications and data are subject to change without notice.

Vishay Intertechnology, Inc., its affiliates, agents, and employees, and all persons acting on its or their behalf (collectively, "Vishay"), disclaim any and all liability for any errors, inaccuracies or incompleteness contained herein or in any other disclosure relating to any product.

Vishay disclaims any and all liability arising out of the use or application of any product described herein or of any information provided herein to the maximum extent permitted by law. The product specifications do not expand or otherwise modify Vishay's terms and conditions of purchase, including but not limited to the warranty expressed therein, which apply to these products.

No license, express or implied, by estoppel or otherwise, to any intellectual property rights is granted by this document or by any conduct of Vishay.

The products shown herein are not designed for use in medical, life-saving, or life-sustaining applications unless otherwise expressly indicated. Customers using or selling Vishay products not expressly indicated for use in such applications do so entirely at their own risk and agree to fully indemnify Vishay for any damages arising or resulting from such use or sale. Please contact authorized Vishay personnel to obtain written terms and conditions regarding products designed for such applications.

Product names and markings noted herein may be trademarks of their respective owners.