

Low Power 3.3V/3.0V μ P Reset, Active LOW, Open-Drain Output

General Description

The ASM1816 is a voltage supervisory device with low-power, 3.3V/3V μ P Reset, active LOW, open-drain output. Maximum supply current over temperature is a low 15 μ A (at 3.6V).

The ASM1816 generates an active LOW reset signal whenever the monitored supply is out of tolerance. A precision reference and comparator circuit monitor power supply (V_{CC}) level. Tolerance level options are 5%, 10%, 15% and 20%. When an out-of-tolerance condition is detected, an internal power-fail signal is generated which forces an active LOW reset signal. After V_{CC} returns to an in-tolerance condition, the reset signal remains active for 150ms to allow the power supply and system microprocessor to stabilize.

The ASM1816 is designed with a open-drain output stage and operates over the extended industrial temperature range. Devices are available in TO-92 and compact surface mount SOT-23 packages.

Other low power products in this family include the ASM1810/11/12/15/17, ASM1233D and ASM1233M.

Key Features

- Low Supply Current
 - 20 μ A maximum (5.5 V)
 - 15 μ A maximum (3.6 V)
- Automatically restarts a microprocessor after power failure
- 150ms reset delay after V_{CC} returns to an in-tolerance condition
- Active LOW power-up reset
- Precision temperature-compensated voltage reference and comparator
- Eliminates external components
- TO-92 and compact surface mount SOT-23 package
- Operating temperature -40°C to +85°C

Applications

- Set-top boxes
- Cellular phones
- PDAs
- Energy management systems
- Embedded control systems
- Printers
- Single board computers

Typical Application

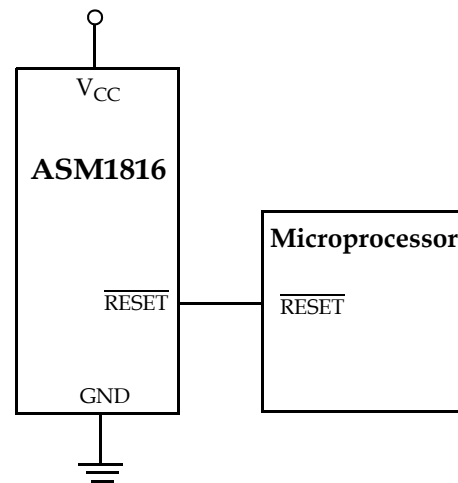

Block Diagram

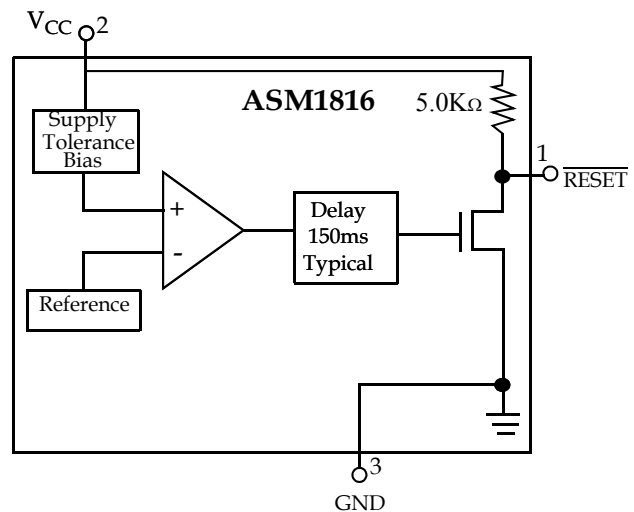

rev 1.6

Pin Configuration

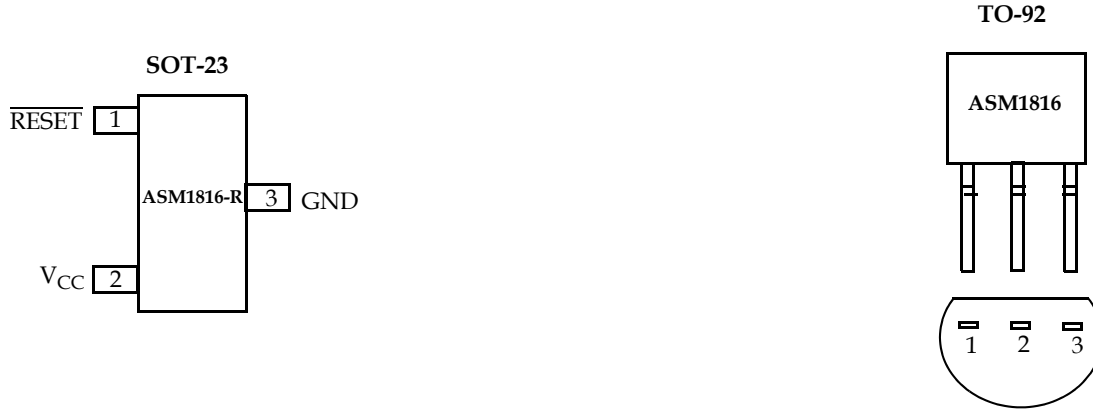

Pin Description

TO-92	SOT-23	Pin Name	Description
Pin #	Pin #		
1	1	$\overline{\text{RESET}}$	Active LOW reset output
2	2	V_{CC}	Power supply input
3	3	GND	Ground

rev 1.6

Application Information

Operation - Power Monitor

The ASM1816 detects out-of-tolerance power supply conditions. It resets a processor during power-up, power-down and issues a reset to the system processor when the monitored power supply voltage is below the reset threshold. When an out-of-tolerance V_{CC} voltage is detected, the $\overline{\text{RESET}}$ signal is asserted. On power-up, $\overline{\text{RESET}}$ is kept active (LOW) for approximately 150ms after the power supply voltage has reached the selected tolerance. This allows the power supply and microprocessor to stabilize before $\overline{\text{RESET}}$ is released.

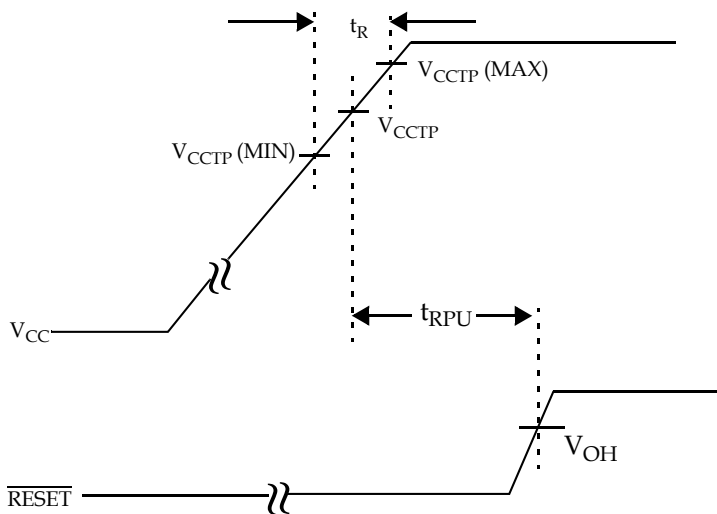

Figure 1: Timing Diagram: Power-Up

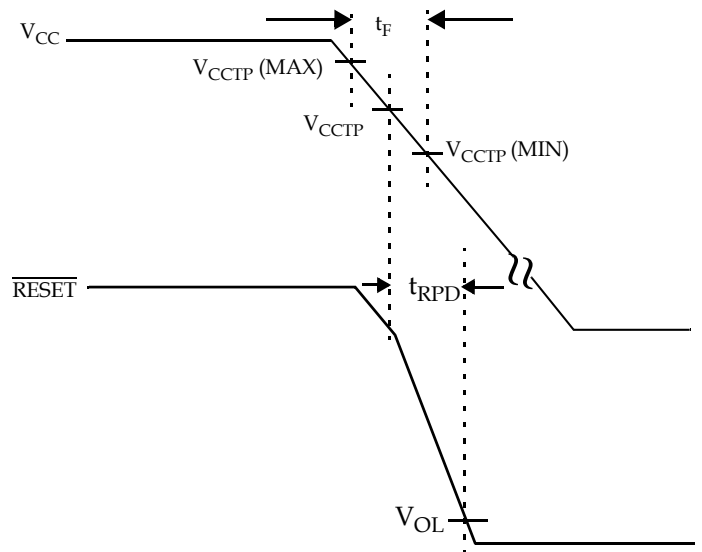

Figure 2: Timing Diagram: Power-Down

rev 1.6

Absolute Maximum Ratings

Parameter	Min	Max	Unit
Voltage on V_{CC}	-0.5	7	V
Voltage on \overline{RESET}	-0.5	$V_{CC} + 0.5$	V
Operating Temperature Range	-40	85	°C
Soldering Temperature (for 10 sec)		260	°C
Storage Temperature	-55	125	°C
ESD rating	HBM	2	KV
	MM	200	V

NOTE: These are stress ratings only and functional use is not implied. Exposure to absolute maximum ratings for prolonged periods of time may affect device reliability.

Electrical Characteristics

Unless otherwise noted, $V_{CC} = 1.2V$ to $5.5V$ and specifications are over the operating temperature range of $-40^{\circ}C$ to $+85^{\circ}C$. All voltages are referenced to ground

Parameter	Symbol	Conditions	Min	Typ	Max	Unit
Supply Voltage	V_{CC}		1.2		5.5	V
Output Current	I_{OL}	Output = 0.4V, $V_{CC} \geq 2.7V$	+10			mA
Operating Current	I_{CC}	$V_{CC} < 5.5V$, \overline{RESET} output open		8	20	μA
Operating Current	I_{CC}	$V_{CC} \leq 3.6V$, \overline{RESET} output open		6	15	μA
V_{CC} Trip Point (ASM1816R-5)	V_{CCTP}		2.98	3.06	3.15	V
V_{CC} Trip Point (ASM1816R-10)	V_{CCTP}		2.80	2.88	2.97	V
V_{CC} Trip Point (ASM1816R-15)	V_{CCTP}		2.635	2.72	2.805	V
V_{CC} Trip Point (ASM1816R-20)	V_{CCTP}		2.47	2.55	2.64	V
Internal Pull-up Resistor	R_P		3.5	5.5	7.5	$k\Omega$
Output Capacitance	C_{OUT}				10	pF
V_{CC} Detect to \overline{RESET} Low	t_{RPD}			2	5	μs
V_{CC} Slew Rate (V_{CCTP} (MAX) to V_{CCTP} (MIN))	t_F		300			μs
V_{CC} Slew Rate (V_{CCTP} (MIN) to V_{CCTP} (MAX))	t_R		0			ns
V_{CC} Detect to \overline{RESET} High	t_{RPU}	$t_r = 5\mu s$	100	150	250	ms

Note: The t_F value is for reference in defining values for t_{RPD} and should not be considered for proper operation or use.

rev 1.6

Family Selection Guide

Part #	RESET Voltage (V)	RESET Time (ms)	Output Stage	RESET Polarity
ASM1810	4.620, 4.370, 4.120	150	Push-Pull	LOW
ASM1811	4.620, 4.350, 4.130	150	Open-Drain	LOW
ASM1812	4.620, 4.350, 4.130	150	Push-Pull	HIGH
ASM1815	3.060, 2.880, 2.550	150	Push-Pull	LOW
ASM1816	3.060, 2.720, 2.880, 2.550	150	Open-Drain	LOW
ASM1817	3.060, 2.880, 2.550	150	Push-Pull	HIGH
ASM1233D	4.625, 4.375, 4.125	350	Open-Drain	LOW
ASM1233M	4.625, 4.375, 2.720	350	Open-Drain	LOW

rev 1.6

Package Dimension

Plastic SOT-23 (3-Pin)

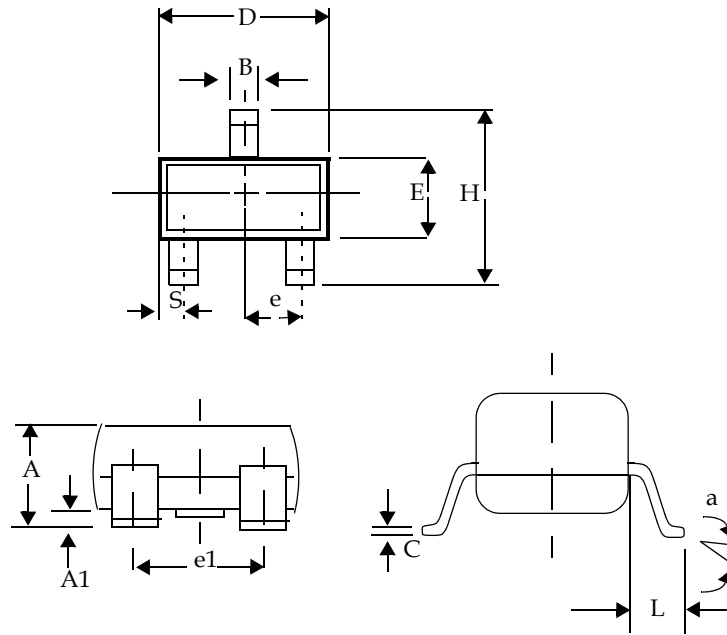

	Inches		Millimeters	
	Min	Max	Min	Max
Plastic SOT-23 (3-Pin)				
A	0.030	0.046	0.75	1.17
A1	0.002	0.006	0.05	0.15
B	0.012	0.020	0.30	0.50
C	0.003	0.008	0.08	0.20
D	0.110	0.120	2.80	3.04
E	0.047	0.055	1.20	1.40
e	0.037 BSC		0.95 BSC	
e1	0.075 BSC		1.9 BSC	
H	0.083	0.104	2.10	2.64
L	0.016	0.024	0.40	0.60
a	0°	8°	0°	8°
S	NA		NA	

rev 1.6

To-92 (3-Pin)

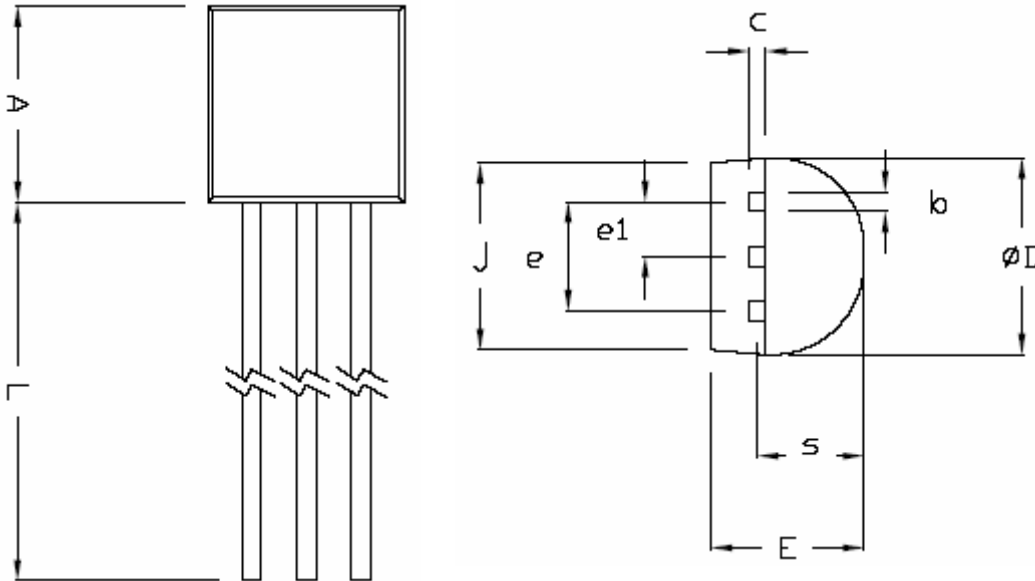

	Dimensions in Inches		Dimensions in Millimeters	
	Min	Max	Min	Max
TO-92				
A	0.175	0.185	4.445	4.699
b	0.016	0.020	0.406	0.508
C	0.014	0.016	0.356	0.406
φD	0.175	0.185	4.445	4.699
E	0.138	0.144	3.505	3.658
e	0.098	0.102	2.489	2.591
e1	0.045	0.055	1.143	1.397
j	0.168	0.174	4.269	4.420
L	0.500	0.585	12.7	14.86
s	0.095	0.099	2.413	2.515

rev 1.6

Ordering Information

Device Summary							
Part *** Number	RESET Output Voltage (V)	RESET Tolerance (%)	RESET Time (ms)	Open-Drain ** Output Stage	SOT-23 Package	RESET Polarity	Package Marking
TIN - LEAD DEVICES							
ASM1816R-5	3.06	5	150	◆	◆	LOW	RMLL
ASM1816R-10	2.88	10	150	◆	◆	LOW	RNLL
ASM1816R-15	2.72	15	150	◆	◆	LOW	RZLL
ASM1816R-20	2.55	20	150	◆	◆	LOW	ROLL
LEAD FREE DEVICES							
ASM1816R-5F	3.06	5	150	◆	◆	LOW	KMLL
ASM1816R-10F	2.88	10	150	◆	◆	LOW	KNLL
ASM1816R-15F	2.72	15	150	◆	◆	LOW	KZLL
ASM1816R-20F	2.55	20	150	◆	◆	LOW	KOLL
Part *** Number	RESET Output Voltage (V)	RESET Tolerance (%)	RESET Time (ms)	Open-Drain ** Output Stage	TO-92 Package	RESET Polarity	Package Marking
TIN - LEAD DEVICES							
ASM1816-5	3.06	5	150	◆	◆	LOW	ASM1816-5
ASM1816-10	2.88	10	150	◆	◆	LOW	ASM1816-10
ASM1816-20	2.55	20	150	◆	◆	LOW	ASM1816-20
LEAD FREE DEVICES							
ASM1816-5F	3.06	5	150	◆	◆	LOW	ASM1816-5F
ASM1816-10F	2.88	10	150	◆	◆	LOW	ASM1816-10F
ASM1816-20F	2.55	20	150	◆	◆	LOW	ASM1816-20F
** Internal 5.5kΩ resistor pull-up ** *Add /T to Part Number for Tape and Reel (i.e ASM18xx-x/T) LL - Lot Code							



PulseCore Semiconductor Corporation
1715 S, Bascom Ave Suit 200
Campbell, CA 95008.
Tel: 408 - 879 - 9077
Fax: 408 - 879 - 9018
www.pulsecoresemi.com

Copyright © PulseCore Semiconductor
All Rights Reserved
Part Number: ASM1816
Document Version: 1.6

© Copyright 2006 PulseCore Semiconductor Corporation. All rights reserved. Our logo and name are trademarks or registered trademarks of PulseCore Semiconductor. All other brand and product names may be the trademarks of their respective companies. PulseCore reserves the right to make changes to this document and its products at any time without notice. PulseCore assumes no responsibility for any errors that may appear in this document. The data contained herein represents PulseCore's best data and/or estimates at the time of issuance. PulseCore reserves the right to change or correct this data at any time, without notice. If the product described herein is under development, significant changes to these specifications are possible. The information in this product data sheet is intended to be general descriptive information for potential customers and users, and is not intended to operate as, or provide, any guarantee or warrantee to any user or customer. PulseCore does not assume any responsibility or liability arising out of the application or use of any product described herein, and disclaims any express or implied warranties related to the sale and/or use of PulseCore products including liability or warranties related to fitness for a particular purpose, merchantability, or infringement of any intellectual property rights, except as express agreed to in PulseCore's Terms and Conditions of Sale (which are available from PulseCore). All sales of PulseCore products are made exclusively according to PulseCore's Terms and Conditions of Sale. The purchase of products from PulseCore does not convey a license under any patent rights, copyrights; mask works rights, trademarks, or any other intellectual property rights of PulseCore or third parties. PulseCore does not authorize its products for use as critical components in life-supporting systems where a malfunction or failure may reasonably be expected to result in significant injury to the user, and the inclusion of PulseCore products in such life-supporting systems implies that the manufacturer assumes all risk of such use and agrees to indemnify PulseCore against all claims arising from such use.